

## $\Sigma$ -7-Series AC Servo Drive $\Sigma$ -7S SERVOPACK with FT/EX Specification for Transfer and Alignment Application with Special Motor, SGM7D Motor Product Manual

Model: SGD7S-□□□□20A□□□F84  
SGD7S-□□□□30A□□□F84

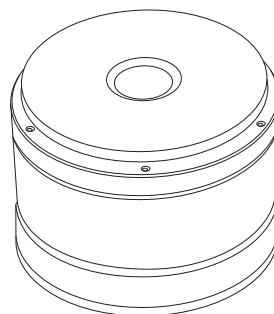
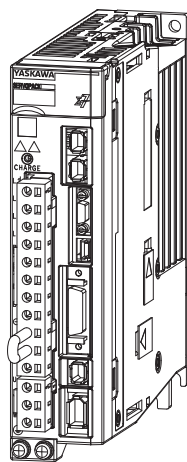

Basic Information on SERVOPACKs	1
SERVOPACK Ratings and Specifications	2
Triggers at Preset Positions	3
Rotational Coordinate System	4
Maintenance	5
Parameter Lists	6

Copyright © 2017 YASKAWA ELECTRIC CORPORATION

---

All rights reserved. No part of this publication may be reproduced, stored in a retrieval system, or transmitted, in any form, or by any means, mechanical, electronic, photocopying, recording, or otherwise, without the prior written permission of Yaskawa. No patent liability is assumed with respect to the use of the information contained herein. Moreover, because Yaskawa is constantly striving to improve its high-quality products, the information contained in this manual is subject to change without notice. Every precaution has been taken in the preparation of this manual. Nevertheless, Yaskawa assumes no responsibility for errors or omissions. Neither is any liability assumed for damages resulting from the use of the information contained in this publication.

## About this Manual

This manual describes the transfer and alignment application option and the SGM7D motor drive application option for  $\Sigma$ -7-Series AC Servo Drive  $\Sigma$ -7S SERVOPACKs.

Read and understand this manual to ensure correct usage of the  $\Sigma$ -7-Series AC Servo Drives.

Keep this manual in a safe place so that it can be referred to whenever necessary.

## Outline of Manual

The contents of the chapters of this manual are described in the following table.

When you use the transfer and alignment application option for  $\Sigma$ -7-Series SERVOPACKs, use this manual and the relevant manual given in the following table.

Item	This Manual	$\Sigma$ -7-Series AC Servo Drive $\Sigma$ -7S SERVOPACK Product Manual	
		SERVOPACKs with MECHATROLIN K-III Communications References (Manual No.: SIEP S800001 28)	SERVOPACKs with MECHATROLIN K-III Communications References and RJ-45 Connectors (Manual No.: SIEP S800001 62)
Basic Information on SERVOPACKs	The $\Sigma$ -7 Series	–	1.1
	Product Introduction	1.1	–
	Interpreting the Nameplate	–	1.2
	Part Names	–	1.3
	Model Designations	–	1.4
	Combinations of SERVOPACKs and Servomotors	–	1.5
	Functions	1.4	–
	SigmaWin+	1.5	–
Selecting a SERVOPACK	Ratings	2.1	–
	SERVOPACK Overload Protection Characteristics	2.2	–
	Specifications	2.3	–
	Block Diagrams	–	2.2
	External Dimensions	–	2.3
	Examples of Standard Connections between SERVOPACKs and Peripheral Devices	–	2.4
SERVOPACK Installation	–	Chapter 3	
Wiring and Connecting SERVOPACKs	–	Chapter 4	
Basic Functions That Require Setting before Operation	–	Chapter 5	
Application Functions	–	Chapter 6	
Trial Operation and Actual Operation	–	Chapter 7	
Tuning	–	Chapter 8	

Continued on next page.

Continued from previous page.

Item		This Manual	Σ-7-Series AC Servo Drive Σ-7S SERVOPACK Product Manual	
			SERVOPACKs with MECHATROLIN K-III Communi- cations References (Manual No.: SIEP S800001 28)	SERVOPACKs with MECHATROLIN K-III Communi- cations References and RJ-45 Connec- tors (Manual No.: SIEP S800001 62)
Monitoring	Monitoring Product Information	–	9.1	
	Monitoring SERVOPACK Status	–	9.2	
	Monitoring Machine Operation Status and Sig- nal Waveforms	–	9.3	
	Monitoring Product Life	–	9.4	
Fully-Closed Loop Control		–	Chapter 10	
Safety Functions		–	Chapter 11	
Triggers at Pre- set Positions	Outline	3.1	–	
	Settings for Triggers at Preset Positions	3.2	–	
	Forced Stop Setting for Triggers at Preset Positions	3.3	–	
Rotational Coordi- nate System	Outline	4.1	–	
	Setup Procedure	4.2	–	
Maintenance	Inspections and Part Replacement	–	12.1	
	Alarm Displays	5.1	–	
	List of Alarms	5.2	–	
	Troubleshooting Alarms	5.3	–	
	Warning Displays	5.4	–	
	List of Warnings	5.5	–	
	Troubleshooting Warnings	5.6	–	
Parameter Lists	Interpreting the Parameter Lists	6.1	–	
	List of Servo Parameters	6.2	–	
	List of MECHATROLINK-III Common Parame- ters	6.3	–	
Appendices		–	Chapter 14	

# Related Documents

The relationships between the documents that are related to the Servo Drives are shown in the following figure. The numbers in the figure correspond to the numbers in the table on the following pages. Refer to these documents as required.

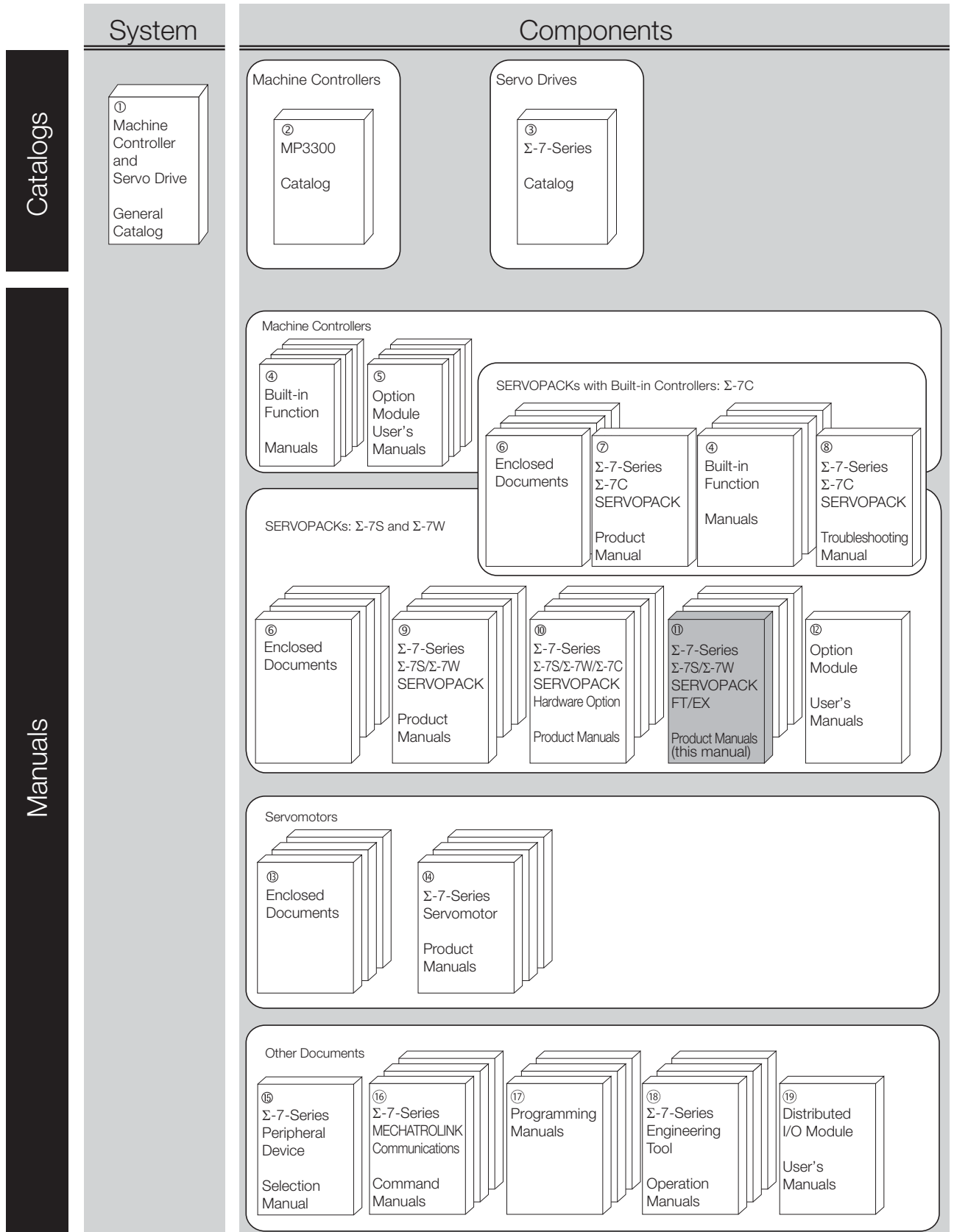

Classification	Document Name	Document No.	Description
① Machine Controller and Servo Drive General Catalog	Machine Controller and AC Servo Drive Solutions Catalog	KAEP S800001 22	Describes the features and application examples for combinations of MP3000-Series Machine Controllers and $\Sigma$ -7-Series AC Servo Drives.
② MP3300 Catalog	Machine Controller MP3300	KAEP C880725 03	Provides detailed information on MP3300 Machine Controllers, including features and specifications.
③ $\Sigma$ -7-Series Catalog	AC Servo Drives $\Sigma$ -7 Series	KAEP S800001 23	Provides detailed information on $\Sigma$ -7-Series AC Servo Drives, including features and specifications.
④ Built-in Function Manuals	$\Sigma$ -7-Series AC Servo Drive $\Sigma$ -7C SERVOPACK Motion Control User's Manual	SIEP S800002 03	Provides detailed information on the specifications, system configuration, and application methods of the Motion Control Function Modules (SVD, SVC4, and SVR4) for $\Sigma$ -7-Series $\Sigma$ -7C SERVOPACKS.
	Machine Controller MP3000 Series Communications User's Manual	SIEP C880725 12	Provides detailed information on the specifications, system configuration, and communications connection methods for the Ethernet communications that are used with MP3000-Series Machine Controllers and $\Sigma$ -7-Series $\Sigma$ -7C SERVOPACKS.
⑤ Option Module User's Manuals	Machine Controller MP2000 Series Communication Module User's Manual	SIEP C880700 04	Provide detailed information on the specifications and communications methods for the Communications Modules that can be mounted to MP3000-Series Machine Controllers and $\Sigma$ -7-Series $\Sigma$ -7C SERVOPACKS.
	Machine Controller MP2000 Series 262IF-01 FL-net Communication Module User's Manual	SIEP C880700 36	
	Machine Controller MP2000 Series 263IF-01 EtherNet/IP Communication Module User's Manual	SIEP C880700 39	
	Machine Controller MP2000 Series I/O Module User's Manual	SIEP C880700 34	Provide detailed information on the specifications and communications methods for the I/O Modules that can be mounted to MP3000-Series Machine Controllers and $\Sigma$ -7-Series $\Sigma$ -7C SERVOPACKS.
	Machine Controller MP2000 Series Analog Input/Analog Output Module AI-01/AO-01 User's Manual	SIEP C880700 26	
	Machine Controller MP2000 Series Counter Module CNTR-01 User's Manual	SIEP C880700 27	

Continued on next page.

Continued from previous page.

Classification	Document Name	Document No.	Description
⑥ Enclosed Documents	Σ-7-Series AC Servo Drive Σ-7S and Σ-7W SERVOPACK Safety Precautions	TOMP C710828 00	Provides detailed information for the safe usage of Σ-7-Series SERVOPACKs.
	Σ-V-Series/Σ-V-Series for Large-Capacity Models/ Σ-7-Series Safety Precautions Option Module	TOBP C720829 00	Provides detailed information for the safe usage of Option Modules.
	Σ-V-Series/Σ-V-Series for Large-Capacity Models/ Σ-7-Series Installation Guide Command Option Module	TOBP C720829 01	Provides detailed procedures for installing the Command Option Module in a SERVOPACK.
	Σ-V-Series/Σ-V-Series for Large-Capacity Models/ Σ-7-Series Installation Guide Fully-closed Module	TOBP C720829 03	Provides detailed procedures for installing the Fully-closed Module in a SERVOPACK.
	Σ-V-Series/Σ-V-Series for Large-Capacity Models/ Σ-7-Series Installation Guide Safety Module	TOBP C720829 06	Provides detailed procedures for installing the Safety Module in a SERVOPACK.
	Σ-V-Series/Σ-V-Series for Large-Capacity Models/ Σ-7-Series Installation Guide INDEXER Module	TOBP C720829 02	Provides detailed procedures for installing the INDEXER Module in a SERVOPACK.
	Σ-V-Series/Σ-V-Series for Large-Capacity Models/ Σ-7-Series Installation Guide DeviceNet Module	TOBP C720829 07	Provides detailed procedures for installing the DeviceNet Module in a SERVOPACK.
⑦ Σ-7-Series Σ-7C SERVOPACK Product Manual	Σ-7-Series AC Servo Drive Σ-7C SERVOPACK Product Manual	SIEP S800002 04	Provides detailed information on selecting Σ-7-Series Σ-7C SERVOPACKs; installing, connecting, setting, testing in trial operation, and tuning Servo Drives; writing, monitoring, and maintaining programs; and other information.
⑧ Σ-7-Series Σ-7C SERVOPACK Troubleshooting Manual	Σ-7-Series AC Servo Drive Σ-7C SERVOPACK Troubleshooting Manual	SIEP S800002 07	Provides detailed troubleshooting information for Σ-7-Series Σ-7C SERVOPACKs.

Continued on next page.

Continued from previous page.

Classification	Document Name	Document No.	Description
⑨ Σ-7-Series Σ-7S/Σ-7W SERVOPACK Product Manuals	Σ-7-Series AC Servo Drive Σ-7S SERVOPACK with MECHATROLINK-III Communications References Product Manual	SIEP S800001 28	Provide detailed information on selecting Σ-7-Series Σ-7S and Σ-7W SERVOPACKS; installing, connecting, setting, testing in trial operation, tuning, monitoring, and maintaining Servo Drives; and other information.
	Σ-7-Series AC Servo Drive Σ-7S SERVOPACK with MECHATROLINK-II Communications References Product Manual	SIEP S800001 27	
	Σ-7-Series AC Servo Drive Σ-7S SERVOPACK with Analog Voltage/Pulse Train References Product Manual	SIEP S800001 26	
	Σ-7-Series AC Servo Drive Σ-7S SERVOPACK Command Option Attachable Type with INDEXER Module Product Manual	SIEP S800001 64	
	Σ-7-Series AC Servo Drive Σ-7S SERVOPACK Command Option Attachable Type with DeviceNet Module Product Manual	SIEP S800001 70	
	Σ-7-Series AC Servo Drive Σ-7W SERVOPACK with MECHATROLINK-III Communications References Product Manual	SIEP S800001 29	
⑩ Σ-7-Series Σ-7S/Σ-7W/Σ-7C SERVOPACK with Hardware Option Specifications Product Manuals	Σ-7-Series AC Servo Drive Σ-7S/Σ-7W SERVOPACK with Hardware Option Specifica- tions Dynamic Brake Product Manual	SIEP S800001 73	Provides detailed information on Hardware Options for Σ-7-Series SERVOPACKS.
	Σ-7-Series AC Servo Drive Σ-7W/Σ-7C SERVOPACK with Hardware Option Specifica- tions HWBB Function Product Manual	SIEP S800001 72	
⑪ Σ-7-Series Σ-7S/Σ-7W SERVOPACK FT/EX Product Manuals	Σ-7-Series AC Servo Drive Σ-7S SERVOPACK with FT/EX Specification for Index- ing Application Product Manual	SIEP S800001 84	Provides detailed information on the FT/EX Option for Σ-7-Series SERVOPACKS.
	Σ-7-Series AC Servo Drive Σ-7S SERVOPACK with FT/EX Specification for Track- ing Application Product Manual	SIEP S800001 89	
	Σ-7-Series AC Servo Drive Σ-7S SERVOPACK with FT/EX Specification for Application with Special Motor, SGM7D Motor Product Manual	SIEP S800001 91	

Continued on next page.



Continued from previous page.

Classification	Document Name	Document No.	Description
⑩ Σ-7-Series Σ-7S/Σ-7W SERVOPACK FT/EX Product Manuals	Σ-7-Series AC Servo Drive Σ-7S SERVOPACK with FT/EX Specification for Press and Injection Molding Application Product Manual	SIEP S800001 94	Provides detailed information on the FT/EX Option for Σ-7-Series SERVOPACKs.
	Σ-7-Series AC Servo Drive Σ-7S SERVOPACK with FT/EX Specification for Transfer and Alignment Application Product Manual	SIEP S800001 95	
	Σ-7-Series AC Servo Drive Σ-7S SERVOPACK with FT/EX Specification for Torque/Force Assistance for Conveyance Application Product Manual	SIEP S800002 09	
	Σ-7-Series AC Servo Drive Σ-7S SERVOPACK with FT/EX Specification for Cutting Application Feed Shaft Motor Product Manual	SIEP S800002 10	
	Σ-7-Series AC Servo Drive Σ-7S SERVOPACK with FT/EX Specification for Three-Point Latching for Conveyance Application Product Manual	SIEP S800002 17	
	Σ-7-Series AC Servo Drive Σ-7S SERVOPACK with FT/EX Specification for Semi-/Fully-Closed Loop Control Online Switching for Conveyance Application Product Manual	SIEP S800002 27	
	Σ-7-Series AC Servo Drive Σ-7S SERVOPACK with FT/EX Specification for Transfer and Alignment Application with Special Motor, SGM7D Motor Product Manual	This manual (SIEP S800002 28)	
	Σ-7-Series AC Servo Drive Σ-7W SERVOPACK with FT/EX Specification for Gantry Applications Product Manual	SIEP S800002 29	
⑩ Option Module User's Manual	AC Servo Drives Σ-V-Series/Σ-V-Series for Large-Capacity Models/ Σ-7-Series User's Manual Safety Module	SIEP C720829 06	Provides details information required for the design and mainte- nance of a Safety Module.

Continued on next page.

Continued from previous page.

Classification	Document Name	Document No.	Description
⑬ Enclosed Documents	AC Servo Drive Rotary Servomotor Safety Precautions	TOBP C230260 00	Provides detailed information for the safe usage of Rotary Servomotors and Direct Drive Servomotors.
	AC Servomotor Linear $\Sigma$ Series Safety Precautions	TOBP C230800 00	Provides detailed information for the safe usage of Linear Servomotors.
⑭ $\Sigma$ -7-Series Servomotor Product Manuals	$\Sigma$ -7-Series AC Servo Drive Rotary Servomotor Product Manual	SIEP S800001 36	Provide detailed information on selecting, installing, and connecting the $\Sigma$ -7-Series Servomotors.
	$\Sigma$ -7-Series AC Servo Drive Linear Servomotor Product Manual	SIEP S800001 37	
	$\Sigma$ -7-Series AC Servo Drive Direct Drive Servomotor Product Manual	SIEP S800001 38	
⑮ $\Sigma$ -7-Series Peripheral Device Selection Manual	$\Sigma$ -7-Series AC Servo Drive Peripheral Device Selection Manual	SIEP S800001 32	Describes the peripheral devices for a $\Sigma$ -7-Series Servo System.
⑯ $\Sigma$ -7-Series MECHATROLINK Communications Command Manuals	$\Sigma$ -7-Series AC Servo Drive MECHATROLINK-II Communications Command Manual	SIEP S800001 30	Provides detailed information on the MECHATROLINK-II communications commands that are used for a $\Sigma$ -7-Series Servo System.
	$\Sigma$ -7-Series AC Servo Drive MECHATROLINK-III Communications Standard Servo Profile Command Manual	SIEP S800001 31	Provides detailed information on the MECHATROLINK-III communications standard servo profile commands that are used for a $\Sigma$ -7-Series Servo System.
⑰ Programming Manuals	Machine Controller MP3000 Series Ladder Programming Manual	SIEP C880725 13	Provides detailed information on the ladder programming specifications and instructions for MP3000-Series Machine Controllers and $\Sigma$ -7-Series $\Sigma$ -7C SERVOPACKs.
	Machine Controller MP3000 Series Motion Programming Manual	SIEP C880725 14	Provides detailed information on the motion programming and sequence programming specifications and instructions for MP3000-Series Machine Controllers and $\Sigma$ -7-Series $\Sigma$ -7C SERVOPACKs.

Continued on next page.

Continued from previous page.

Classification	Document Name	Document No.	Description
<sup>®</sup> $\Sigma$ -7-Series Operation Interface Operating Manuals	Machine Controller MP2000/MP3000 Series Engineering Tool MPE720 Version 7 User's Manual	SIEP C880761 03	Describes in detail how to operate MPE720 version 7.
	$\Sigma$ -7-Series AC Servo Drive Digital Operator Operating Manual	SIEP S800001 33	Describes the operating procedures for a Digital Operator for a $\Sigma$ -7-Series Servo System.
	AC Servo Drive Engineering Tool SigmaWin+ Operation Manual	SIET S800001 34	Provides detailed operating procedures for the SigmaWin+ Engineering Tool for a $\Sigma$ -7-Series Servo System.
<sup>®</sup> Distributed I/O Module User's Manuals	MECHATROLINK-III Compatible I/O Module User's Manual	SIEP C880781 04	Describes the functions, specifications, operating methods, and MECHATROLINK-III communications for the Remote I/O Modules for MP2000/MP3000-Series Machine Controllers.

# Using This Manual

## ◆ Technical Terms Used in This Manual

The following terms are used in this manual.

Term	Meaning
Servomotor	A $\Sigma$ -7-Series Direct Drive Servomotor.
SERVOPACK	A $\Sigma$ -7-Series $\Sigma$ -7S Servo Amplifier with MECHATROLINK-III Communications References.
Servo Drive	The combination of a Servomotor and SERVOPACK.
Servo System	A servo control system that includes the combination of a Servo Drive with a host controller and peripheral devices.
servo ON	Supplying power to the motor.
servo OFF	Not supplying power to the motor.
base block (BB)	Shutting OFF the power supply to the motor by shutting OFF the base current to the power transistor in the SERVOPACK.
servo lock	A state in which the motor is stopped and is in a position loop with a position reference of 0.
Main Circuit Cable	One of the cables that connect to the main circuit terminals, including the Main Circuit Power Supply Cable, Control Power Supply Cable, and Servomotor Main Circuit Cable.
SigmaWin+	The Engineering Tool for setting up and tuning Servo Drives or a computer in which the Engineering Tool is installed.

## ◆ Notation Used in this Manual

### ■ Notation for Reverse Signals

The names of reverse signals (i.e., ones that are valid when low) are written with a forward slash (/) before the signal abbreviation.

Notation Example

$\overline{BK}$  is written as /BK.

### ■ Notation for Parameters

The notation depends on whether the parameter requires a numeric setting (parameter for numeric setting) or requires the selection of a function (parameter for selecting functions).

#### • Parameters for Numeric Settings

The control methods for which the parameters apply are given.  
Speed : Speed control Position : Position control Torque : Torque control

Pn100	Speed Loop Gain					<span style="border: 1px solid black; padding: 2px;">Speed</span> <span style="border: 1px solid black; padding: 2px;">Position</span>
	Setting Range	Setting Unit	Default Setting	When Enabled	Classification	
	10 to 20,000	0.1 Hz	400	Immediately	Tuning	

Parameter number: Pn100  
 This is the setting range for the parameter.  
 This is the minimum unit (setting increment) that you can set for the parameter.  
 This is the parameter setting before shipment.  
 This is when any change made to the parameter will become effective.  
 This is the parameter classification.

#### • Parameters for Selecting Functions

Parameter	Meaning	When Enabled	Classification
Pn002	n.□□□□ (default setting)	After restart	Setup
	n.□1□□		
	n.□2□□		

Parameter number: Pn002  
 The notation "n.□□□□" indicates a parameter for selecting functions. Each □ indicates the setting for one digit. The notation shown here means that the third digit from the right is set to 2.  
 This column explains the selections for the function.

Notation Example

Notation Examples for Pn002

n . 0 0 0 0	Digit Notation		Numeric Value Notation	
	Notation	Meaning	Notation	Meaning
→	Pn002 = n.□□□X	Indicates the first digit from the right in Pn002.	Pn002 = n.□□□1	Indicates that the first digit from the right in Pn002 is set to 1.
→	Pn002 = n.□□X□	Indicates the second digit from the right in Pn002.	Pn002 = n.□□1□	Indicates that the second digit from the right in Pn002 is set to 1.
→	Pn002 = n.□X□□	Indicates the third digit from the right in Pn002.	Pn002 = n.□1□□	Indicates that the third digit from the right in Pn002 is set to 1.
→	Pn002 = n.X□□□	Indicates the fourth digit from the right in Pn002.	Pn002 = n.1□□□	Indicates that the fourth digit from the right in Pn002 is set to 1.

## ◆ Engineering Tools Used in This Manual

This manual uses the interfaces of the SigmaWin+ for descriptions.

---

## ◆ Trademarks

- QR code is a trademark of Denso Wave Inc.
- MECHATROLINK is a trademark of the MECHATROLINK Members Association.
- Other product names and company names are the trademarks or registered trademarks of the respective company. “TM” and the ® mark do not appear with product or company names in this manual.

## ◆ Visual Aids

The following aids are used to indicate certain types of information for easier reference.



Indicates precautions or restrictions that must be observed.  
Also indicates alarm displays and other precautions that will not result in machine damage.



Indicates definitions of difficult terms or terms that have not been previously explained in this manual.

**Example** Indicates operating or setting examples.

**Information** Indicates supplemental information to deepen understanding or useful information.

---

# Safety Precautions

## ◆ Safety Information

To prevent personal injury and equipment damage in advance, the following signal words are used to indicate safety precautions in this document. The signal words are used to classify the hazards and the degree of damage or injury that may occur if a product is used incorrectly. Information marked as shown below is important for safety. Always read this information and heed the precautions that are provided.



### DANGER

- Indicates precautions that, if not heeded, are likely to result in loss of life, serious injury, or fire.



### WARNING

- Indicates precautions that, if not heeded, could result in loss of life, serious injury, or fire.



### CAUTION

- Indicates precautions that, if not heeded, could result in relatively serious or minor injury, or in fire.

### NOTICE

- Indicates precautions that, if not heeded, could result in property damage.

---

## ◆ Safety Precautions That Must Always Be Observed

### ■ General Precautions



## DANGER

- Read and understand this manual to ensure the safe usage of the product.
- Keep this manual in a safe, convenient place so that it can be referred to whenever necessary. Make sure that it is delivered to the final user of the product.
- Do not remove covers, cables, connectors, or optional devices while power is being supplied to the SERVOPACK.  
There is a risk of electric shock, operational failure of the product, or burning.



## WARNING

- Use a power supply with specifications (number of phases, voltage, frequency, and AC/DC type) that are appropriate for the product.  
There is a risk of burning, electric shock, or fire.
- Connect the ground terminals on the SERVOPACK and Servomotor to ground poles according to local electrical codes (100  $\Omega$  or less for a SERVOPACK with a 100-VAC or 200-VAC power supply, and 10  $\Omega$  or less for a SERVOPACK with a 400-VAC power supply).  
There is a risk of electric shock or fire.
- Do not attempt to disassemble, repair, or modify the product.  
There is a risk of fire or failure.  
The warranty is void for the product if you disassemble, repair, or modify it.



## CAUTION

- The SERVOPACK heat sinks, regenerative resistors, External Dynamic Brake Resistors, Servomotors, and other components can be very hot while power is ON or soon after the power is turned OFF. Implement safety measures, such as installing covers, so that hands and parts such as cables do not come into contact with hot components.  
There is a risk of burn injury.
- For a 24-VDC power supply, use a power supply device with double insulation or reinforced insulation.  
There is a risk of electric shock.
- Do not damage, pull on, apply excessive force to, place heavy objects on, or pinch cables.  
There is a risk of failure, damage, or electric shock.
- The person who designs the system that uses the hard wire base block safety function must have a complete knowledge of the related safety standards and a complete understanding of the instructions in this document.  
There is a risk of injury, product damage, or machine damage.
- Do not use the product in an environment that is subject to water, corrosive gases, or flammable gases, or near flammable materials.  
There is a risk of electric shock or fire.



## NOTICE

- Do not attempt to use a SERVOPACK or Servomotor that is damaged or that has missing parts.
- Install external emergency stop circuits that shut OFF the power supply and stops operation immediately when an error occurs.
- In locations with poor power supply conditions, install the necessary protective devices (such as AC reactors) to ensure that the input power is supplied within the specified voltage range. There is a risk of damage to the SERVOPACK.
- Use a Noise Filter to minimize the effects of electromagnetic interference. Electronic devices used near the SERVOPACK may be affected by electromagnetic interference.
- Always use a Servomotor and SERVOPACK in one of the specified combinations.
- Do not touch a SERVOPACK or Servomotor with wet hands. There is a risk of product failure.

### ■ Storage Precautions



## CAUTION

- Do not place an excessive load on the product during storage. (Follow all instructions on the packages.) There is a risk of injury or damage.

## NOTICE

- Do not install or store the product in any of the following locations.
  - Locations that are subject to direct sunlight
  - Locations that are subject to ambient temperatures that exceed product specifications
  - Locations that are subject to relative humidities that exceed product specifications
  - Locations that are subject to condensation as the result of extreme changes in temperature
  - Locations that are subject to corrosive or flammable gases
  - Locations that are near flammable materials
  - Locations that are subject to dust, salts, or iron powder
  - Locations that are subject to water, oil, or chemicals
  - Locations that are subject to vibration or shock that exceeds product specifications
  - Locations that are subject to radiationIf you store or install the product in any of the above locations, the product may fail or be damaged.

### ■ Transportation Precautions



## CAUTION

- Transport the product in a way that is suitable to the mass of the product.
- Do not use the eyebolts on a SERVOPACK or Servomotor to move the machine. There is a risk of damage or injury.
- When you handle a SERVOPACK or Servomotor, be careful of sharp parts, such as the corners. There is a risk of injury.
- Do not place an excessive load on the product during transportation. (Follow all instructions on the packages.) There is a risk of injury or damage.

## NOTICE

- Do not hold onto the front cover or connectors when you move a SERVOPACK.  
There is a risk of the SERVOPACK falling.
- A SERVOPACK or Servomotor is a precision device. Do not drop it or subject it to strong shock.  
There is a risk of failure or damage.
- Do not subject connectors to shock.  
There is a risk of faulty connections or damage.
- If disinfectants or insecticides must be used to treat packing materials such as wooden frames, plywood, or pallets, the packing materials must be treated before the product is packaged, and methods other than fumigation must be used.

Example: Heat treatment, where materials are kiln-dried to a core temperature of 56°C for 30 minutes or more.

If the electronic products, which include stand-alone products and products installed in machines, are packed with fumigated wooden materials, the electrical components may be greatly damaged by the gases or fumes resulting from the fumigation process. In particular, disinfectants containing halogen, which includes chlorine, fluorine, bromine, or iodine can contribute to the erosion of the capacitors.

- Do not overtighten the eyebolts on a SERVOPACK or Servomotor.  
If you use a tool to overtighten the eyebolts, the tapped holes may be damaged.

### ■ Installation Precautions



## CAUTION

- Install the Servomotor or SERVOPACK in a way that will support the mass given in technical documents.
- Install SERVOPACKs, Servomotors, regenerative resistors, and External Dynamic Brake Resistors on nonflammable materials.  
Installation directly onto or near flammable materials may result in fire.
- Provide the specified clearances between the SERVOPACK and the control panel as well as with other devices.  
There is a risk of fire or failure.
- Install the SERVOPACK in the specified orientation.  
There is a risk of fire or failure.
- Do not step on or place a heavy object on the product.  
There is a risk of failure, damage, or injury.
- Do not allow any foreign matter to enter the SERVOPACK or Servomotor.  
There is a risk of failure or fire.

## NOTICE

- **Do not install or store the product in any of the following locations.**
  - Locations that are subject to direct sunlight
  - Locations that are subject to ambient temperatures that exceed product specifications
  - Locations that are subject to relative humidities that exceed product specifications
  - Locations that are subject to condensation as the result of extreme changes in temperature
  - Locations that are subject to corrosive or flammable gases
  - Locations that are near flammable materials
  - Locations that are subject to dust, salts, or iron powder
  - Locations that are subject to water, oil, or chemicals
  - Locations that are subject to vibration or shock that exceeds product specifications
  - Locations that are subject to radiationIf you store or install the product in any of the above locations, the product may fail or be damaged.
- **Use the product in an environment that is appropriate for the product specifications.**

If you use the product in an environment that exceeds product specifications, the product may fail or be damaged.
- **A SERVOPACK or Servomotor is a precision device. Do not drop it or subject it to strong shock.**

There is a risk of failure or damage.
- **Always install a SERVOPACK in a control panel.**
- **Do not allow any foreign matter to enter a SERVOPACK or a Servomotor with a Cooling Fan and do not cover the outlet from the Servomotor's cooling fan.**

There is a risk of failure.

### ■ Wiring Precautions



## DANGER

- **Do not change any wiring while power is being supplied.**

There is a risk of electric shock or injury.



## WARNING

- **Wiring and inspections must be performed only by qualified engineers.**

There is a risk of electric shock or product failure.
- **Check all wiring and power supplies carefully.**

Incorrect wiring or incorrect voltage application to the output circuits may cause short-circuit failures. If a short-circuit failure occurs as a result of any of these causes, the holding brake will not work. This could damage the machine or cause an accident that may result in death or injury.
- **Connect the AC and DC power supplies to the specified SERVOPACK terminals.**
  - Connect an AC power supply to the L1, L2, and L3 terminals and the L1C and L2C terminals on the SERVOPACK.
  - Connect a DC power supply to the B1/⊕ and ⊖2 terminals and the L1C and L2C terminals on the SERVOPACK.

There is a risk of failure or fire.
- **If you use a SERVOPACK with the Dynamic Brake Hardware Option, connect an External Dynamic Brake Resistor that is suitable for the machine and equipment specifications to the specified terminals.**

There is a risk of unexpected operation, machine damage, burning, or injury when an emergency stop is performed.



## CAUTION

- Wait for at least six minutes after turning OFF the power supply (with a SERVOPACK for a 100-VAC input, wait for at least nine minutes) and then make sure that the CHARGE indicator is not lit before starting wiring or inspection work. Do not touch the power supply terminals while the CHARGE lamp is lit after turning OFF the power supply because high voltage may still remain in the SERVOPACK.  
There is a risk of electric shock.
- Observe the precautions and instructions for wiring and trial operation precisely as described in this document.  
Failures caused by incorrect wiring or incorrect voltage application in the brake circuit may cause the SERVOPACK to fail, damage the equipment, or cause an accident resulting in death or injury.
- Check the wiring to be sure it has been performed correctly.  
Connectors and pin layouts are sometimes different for different models. Always confirm the pin layouts in technical documents for your model before operation.  
There is a risk of failure or malfunction.
- Connect wires to power supply terminals and motor connection terminals securely with the specified methods and tightening torque.  
Insufficient tightening may cause wires and terminal blocks to generate heat due to faulty contact, possibly resulting in fire.
- Use shielded twisted-pair cables or screened unshielded multi-twisted-pair cables for I/O Signal Cables and Encoder Cables.
- The maximum wiring length is 3 m for I/O Signal Cables, and 50 m for Encoder Cables or Servomotor Main Circuit Cables.
- Observe the following precautions when wiring the SERVOPACK's main circuit terminals.
  - Turn ON the power supply to the SERVOPACK only after all wiring, including the main circuit terminals, has been completed.
  - If a connector is used for the main circuit terminals, remove the main circuit connector from the SERVOPACK before you wire it.
  - Insert only one wire per insertion hole in the main circuit terminals.
  - When you insert a wire, make sure that the conductor wire (e.g., whiskers) does not come into contact with adjacent wires.
- Install molded-case circuit breakers and other safety measures to provide protection against short circuits in external wiring.  
There is a risk of fire or failure.

## NOTICE

- Whenever possible, use the Cables specified by Yaskawa.  
If you use any other cables, confirm the rated current and application environment of your model and use the wiring materials specified by Yaskawa or equivalent materials.
- Securely tighten cable connector screws and lock mechanisms.  
Insufficient tightening may result in cable connectors falling off during operation.
- Do not bundle power lines (e.g., the Main Circuit Cable) and low-current lines (e.g., the I/O Signal Cables or Encoder Cables) together or run them through the same duct. If you do not place power lines and low-current lines in separate ducts, separate them by at least 30 cm.  
If the cables are too close to each other, malfunctions may occur due to noise affecting the low-current lines.
- Install a battery at either the host controller or on the Encoder Cable.  
If you install batteries both at the host controller and on the Encoder Cable at the same time, you will create a loop circuit between the batteries, resulting in a risk of damage or burning.
- When connecting a battery, connect the polarity correctly.  
There is a risk of battery rupture or encoder failure.

## ■ Operation Precautions



### WARNING

- Before starting operation with a machine connected, change the settings of the switches and parameters to match the machine.  
Unexpected machine operation, failure, or personal injury may occur if operation is started before appropriate settings are made.
- Do not radically change the settings of the parameters.  
There is a risk of unstable operation, machine damage, or injury.
- Install limit switches or stoppers at the ends of the moving parts of the machine to prevent unexpected accidents.  
There is a risk of machine damage or injury.
- For trial operation, securely mount the Servomotor and disconnect it from the machine.  
There is a risk of injury.
- Forcing the motor to stop for overtravel is disabled when the Jog, Origin Search, or Easy FFT utility function is executed. Take necessary precautions.  
There is a risk of machine damage or injury.
- When an alarm occurs, the Servomotor will coast to a stop or stop with the dynamic brake according to the SERVOPACK Option and settings. The coasting distance will change with the moment of inertia of the load and the resistance of the External Dynamic Brake Resistor. Check the coasting distance during trial operation and implement suitable safety measures on the machine.
- Do not enter the machine's range of motion during operation.  
There is a risk of injury.
- Do not touch the moving parts of the Servomotor or machine during operation.  
There is a risk of injury.



### CAUTION

- Design the system to ensure safety even when problems, such as broken signal lines, occur. For example, the P-OT and N-OT signals are set in the default settings to operate on the safe side if a signal line breaks. Do not change the polarity of this type of signal.
- When overtravel occurs, the power supply to the motor is turned OFF and the brake is released. If you use the Servomotor to drive a vertical load, set the Servomotor to enter a zero-clamped state after the Servomotor stops. Also, install safety devices (such as an external brake or counterweight) to prevent the moving parts of the machine from falling.
- Always turn OFF the servo before you turn OFF the power supply. If you turn OFF the main circuit power supply or control power supply during operation before you turn OFF the servo, the Servomotor will stop as follows:
  - If you turn OFF the main circuit power supply during operation without turning OFF the servo, the Servomotor will stop abruptly with the dynamic brake.
  - If you turn OFF the control power supply without turning OFF the servo, the stopping method that is used by the Servomotor depends on the model of the SERVOPACK. For details, refer to the manual for the SERVOPACK.
  - If you use a SERVOPACK with the Dynamic Brake Hardware Option, the Servomotor stopping methods will be different from the stopping methods used without the Option or with other Hardware Options. For details, refer to the *Σ-7-Series AC Servo Drive Σ-7S/Σ-7W SERVOPACK with Dynamic Brake Hardware Option Specifications Product Manual*.
- Do not use the dynamic brake for any application other than an emergency stop.  
There is a risk of failure due to rapid deterioration of elements in the SERVOPACK and the risk of unexpected operation, machine damage, burning, or injury.

## NOTICE

- When you adjust the gain during system commissioning, use a measuring instrument to monitor the torque waveform and speed waveform and confirm that there is no vibration.  
If a high gain causes vibration, the Servomotor will be damaged quickly.
- Do not frequently turn the power supply ON and OFF. After you have started actual operation, allow at least one hour between turning the power supply ON and OFF (as a guideline).  
Do not use the product in applications that require the power supply to be turned ON and OFF frequently.  
The elements in the SERVOPACK will deteriorate quickly.
- An alarm or warning may occur if communications are performed with the host controller while the SigmaWin+ or Digital Operator is operating.  
If an alarm or warning occurs, it may interrupt the current process and stop the system.
- After you complete trial operation of the machine and facilities, use the SigmaWin+ to back up the settings of the SERVOPACK parameters. You can use them to reset the parameters after SERVOPACK replacement.  
If you do not copy backed up parameter settings, normal operation may not be possible after a faulty SERVOPACK is replaced, possibly resulting in machine or equipment damage.

### ■ Maintenance and Inspection Precautions

## DANGER

- Do not change any wiring while power is being supplied.  
There is a risk of electric shock or injury.

## WARNING

- Wiring and inspections must be performed only by qualified engineers.  
There is a risk of electric shock or product failure.

## CAUTION

- Wait for at least six minutes after turning OFF the power supply (with a SERVOPACK for a 100-VAC input, wait for at least nine minutes) and then make sure that the CHARGE indicator is not lit before starting wiring or inspection work. Do not touch the power supply terminals while the CHARGE lamp is lit after turning OFF the power supply because high voltage may still remain in the SERVOPACK.  
There is a risk of electric shock.
- Before you replace a SERVOPACK, back up the settings of the SERVOPACK parameters. Copy the backed up parameter settings to the new SERVOPACK and confirm that they were copied correctly.  
If you do not copy backed up parameter settings or if the copy operation is not completed normally, normal operation may not be possible, possibly resulting in machine or equipment damage.

## NOTICE

- Discharge all static electricity from your body before you operate any of the buttons or switches inside the front cover of the SERVOPACK.  
There is a risk of equipment damage.

## ■ Troubleshooting Precautions



### DANGER

- If the safety device (molded-case circuit breaker or fuse) installed in the power supply line operates, remove the cause before you supply power to the SERVOPACK again. If necessary, repair or replace the SERVOPACK, check the wiring, and remove the factor that caused the safety device to operate.

There is a risk of fire, electric shock, or injury.



### WARNING

- The product may suddenly start to operate when the power supply is recovered after a momentary power interruption. Design the machine to ensure human safety when operation restarts.

There is a risk of injury.



### CAUTION

- When an alarm occurs, remove the cause of the alarm and ensure safety. Then reset the alarm or turn the power supply OFF and ON again to restart operation.  
There is a risk of injury or machine damage.
- If the Servo ON signal is input to the SERVOPACK and an alarm is reset, the Servomotor may suddenly restart operation. Confirm that the servo is OFF and ensure safety before you reset an alarm.  
There is a risk of injury or machine damage.
- Always insert a magnetic contactor in the line between the main circuit power supply and the main circuit power supply terminals on the SERVOPACK so that the power supply can be shut OFF at the main circuit power supply.  
If a magnetic contactor is not connected when the SERVOPACK fails, a large current may flow, possibly resulting in fire.
- If an alarm occurs, shut OFF the main circuit power supply.  
There is a risk of fire due to a regenerative resistor overheating as the result of regenerative transistor failure.
- Install a ground fault detector against overloads and short-circuiting or install a molded-case circuit breaker combined with a ground fault detector.  
There is a risk of SERVOPACK failure or fire if a ground fault occurs.
- The holding brake on a Servomotor will not ensure safety if there is the possibility that an external force (including gravity) may move the current position and create a hazardous situation when power is interrupted or an error occurs. If an external force may cause movement, install an external braking mechanism that ensures safety.

## ■ Disposal Precautions

- Correctly discard the product as stipulated by regional, local, and municipal laws and regulations. Be sure to include these contents in all labelling and warning notifications on the final product as necessary.



---

## ■ General Precautions

- Figures provided in this document are typical examples or conceptual representations. There may be differences between them and actual wiring, circuits, and products.
- The products shown in illustrations in this document are sometimes shown without covers or protective guards. Always replace all covers and protective guards before you use the product.
- If you need a new copy of this document because it has been lost or damaged, contact your nearest Yaskawa representative or one of the offices listed on the back of this document.
- This document is subject to change without notice for product improvements, specifications changes, and improvements to the manual itself.  
We will update the document number of the document and issue revisions when changes are made.
- Any and all quality guarantees provided by Yaskawa are null and void if the customer modifies the product in any way. Yaskawa disavows any responsibility for damages or losses that are caused by modified products.



---

# Warranty

## ◆ Details of Warranty

### ■ Warranty Period

The warranty period for a product that was purchased (hereinafter called the “delivered product”) is one year from the time of delivery to the location specified by the customer or 18 months from the time of shipment from the Yaskawa factory, whichever is sooner.

### ■ Warranty Scope

Yaskawa shall replace or repair a defective product free of charge if a defect attributable to Yaskawa occurs during the above warranty period.

This warranty does not cover defects caused by the delivered product reaching the end of its service life and replacement of parts that require replacement or that have a limited service life.

This warranty does not cover failures that result from any of the following causes.

- Improper handling, abuse, or use in unsuitable conditions or in environments not described in product catalogs or manuals, or in any separately agreed-upon specifications
- Causes not attributable to the delivered product itself
- Modifications or repairs not performed by Yaskawa
- Use of the delivered product in a manner in which it was not originally intended
- Causes that were not foreseeable with the scientific and technological understanding at the time of shipment from Yaskawa
- Events for which Yaskawa is not responsible, such as natural or human-made disasters

## ◆ Limitations of Liability

- Yaskawa shall in no event be responsible for any damage or loss of opportunity to the customer that arises due to failure of the delivered product.
- Yaskawa shall not be responsible for any programs (including parameter settings) or the results of program execution of the programs provided by the user or by a third party for use with programmable Yaskawa products.
- The information described in product catalogs or manuals is provided for the purpose of the customer purchasing the appropriate product for the intended application. The use thereof does not guarantee that there are no infringements of intellectual property rights or other proprietary rights of Yaskawa or third parties, nor does it construe a license.
- Yaskawa shall not be responsible for any damage arising from infringements of intellectual property rights or other proprietary rights of third parties as a result of using the information described in catalogs or manuals.

---

## ◆ Suitability for Use

- It is the customer's responsibility to confirm conformity with any standards, codes, or regulations that apply if the Yaskawa product is used in combination with any other products.
- The customer must confirm that the Yaskawa product is suitable for the systems, machines, and equipment used by the customer.
- Consult with Yaskawa to determine whether use in the following applications is acceptable. If use in the application is acceptable, use the product with extra allowance in ratings and specifications, and provide safety measures to minimize hazards in the event of failure.
  - Outdoor use, use involving potential chemical contamination or electrical interference, or use in conditions or environments not described in product catalogs or manuals
  - Nuclear energy control systems, combustion systems, railroad systems, aviation systems, vehicle systems, medical equipment, amusement machines, and installations subject to separate industry or government regulations
  - Systems, machines, and equipment that may present a risk to life or property
  - Systems that require a high degree of reliability, such as systems that supply gas, water, or electricity, or systems that operate continuously 24 hours a day
  - Other systems that require a similar high degree of safety
- Never use the product for an application involving serious risk to life or property without first ensuring that the system is designed to secure the required level of safety with risk warnings and redundancy, and that the Yaskawa product is properly rated and installed.
- The circuit examples and other application examples described in product catalogs and manuals are for reference. Check the functionality and safety of the actual devices and equipment to be used before using the product.
- Read and understand all use prohibitions and precautions, and operate the Yaskawa product correctly to prevent accidental harm to third parties.

## ◆ Specifications Change

The names, specifications, appearance, and accessories of products in product catalogs and manuals may be changed at any time based on improvements and other reasons. The next editions of the revised catalogs or manuals will be published with updated code numbers. Consult with your Yaskawa representative to confirm the actual specifications before purchasing a product.

## Compliance with UL Standards, EU Directives, and Other Safety Standards

Certification marks for the standards for which the product has been certified by certification bodies are shown on nameplate. Products that do not have the marks are not certified for the standards.

### ◆ North American Safety Standards (UL)



Product	Model	North American Safety Standards (UL File No.)
SERVOPACKs	SGD7S	UL 61800-5-1 (E147823), CSA C22.2 No.274

### ◆ European Directives



Product	Model	European Directive	Harmonized Standards
SERVOPACKs	SGD7S	Machinery Directive 2006/42/EC	EN ISO13849-1:2015
		EMC Directive 2014/30/EU	EN 55011 group 1, class A EN 61000-6-2 EN 61000-6-4 EN 61800-3 (Category C2, Second environment)
		Low Voltage Directive 2014/35/EU	EN 50178 EN 61800-5-1
		RoHS Directive 2011/65/EU	EN 50581
Direct Drive Servomotors	SGM7D	EMC Directive 2014/30/EU	EN 55011 group 1, class A EN 61000-6-2 EN 61000-6-4 EN 61800-3 (Category C2, Second environment)
		Low Voltage Directive 2014/35/EU	EN 60034-1 EN 60034-5
		RoHS Directive 2011/65/EU	EN 50581

Note: 1. We declared the CE Marking based on the harmonized standards in the above table.

2. These products are for industrial use. In home environments, these products may cause electromagnetic interference and additional noise reduction measures may be necessary.

### ◆ Safety Standards



Product	Model	Safety Standards	Standards
SERVOPACKs	SGD7S	Safety of Machinery	EN ISO13849-1:2015 IEC 60204-1
		Functional Safety	IEC 61508 series IEC 62061 IEC 61800-5-2
		EMC	IEC 61326-3-1

## ◆ Safety Parameters

Item	Standards	Performance Level	
Safety Integrity Level	IEC 61508	SIL3	
	IEC 62061	SILCL3	
Mission Time	IEC 61508	10 years	20 years
Probability of Dangerous Failure per Hour	IEC 61508 IEC 62061	PFH = $4.04 \times 10^{-9}$ [1/h] (4.04% of SIL3)	PFH = $4.05 \times 10^{-9}$ [1/h] (4.05% of SIL3)
Performance Level	EN ISO 13849-1	PLe (Category 3)	
Mean Time to Dangerous Failure of Each Channel	EN ISO 13849-1	MTTFd: High	
Average Diagnostic Coverage	EN ISO 13849-1	DCavg: Medium	
Stop Category	IEC 60204-1	Stop category 0	
Safety Function	IEC 61800-5-2	STO	
Hardware Fault Tolerance	IEC 61508	HFT = 1	
Subsystem	IEC 61508	B	

# Contents

About this Manual . . . . .	iii
Outline of Manual . . . . .	iii
Related Documents . . . . .	v
Using This Manual . . . . .	xii
Safety Precautions . . . . .	xv
Warranty . . . . .	xxv
Compliance with UL Standards, EU Directives, and Other Safety Standards . .	xxvii

## 1

### Basic Information on SERVOPACKs

<b>1.1</b>	<b>Product Introduction . . . . .</b>	<b>1-2</b>
<b>1.2</b>	<b>Model Designations . . . . .</b>	<b>1-3</b>
1.2.1	Interpreting SERVOPACK Model Numbers . . . . .	1-3
1.2.2	Interpreting Direct Drive Servomotor Model Numbers . . . . .	1-4
<b>1.3</b>	<b>Combinations of SERVOPACKs and Servomotors . . . . .</b>	<b>1-5</b>
<b>1.4</b>	<b>Functions . . . . .</b>	<b>1-6</b>
1.4.1	SERVOPACK Functions . . . . .	1-6
1.4.2	Function Application Restrictions . . . . .	1-8
<b>1.5</b>	<b>SigmaWin+ . . . . .</b>	<b>1-9</b>
<b>1.6</b>	<b>Combining the SERVOPACKs with MP-Series Machine Controllers and the MPE720 Engineering Tool . .</b>	<b>1-10</b>

## 2

### SERVOPACK Ratings and Specifications

<b>2.1</b>	<b>Ratings . . . . .</b>	<b>2-2</b>
2.1.1	Three-Phase, 200 VAC . . . . .	2-2
2.1.2	Single-Phase, 200 VAC . . . . .	2-2
2.1.3	Single-Phase, 100 VAC . . . . .	2-3
<b>2.2</b>	<b>SERVOPACK Overload Protection Characteristics . . . . .</b>	<b>2-4</b>
<b>2.3</b>	<b>Specifications . . . . .</b>	<b>2-5</b>
2.3.1	SERVOPACK with MECHATROLINK-III Communications References . . . . .	2-5
2.3.2	SERVOPACK with MECHATROLINK-III Communications References and RJ-45 Connectors . . . . .	2-8

---

## 3

### Triggers at Preset Positions

---

<b>3.1</b>	<b>Outline</b> . . . . .	<b>3-2</b>
3.1.1	Line-Driver Output Specifications . . . . .	3-3
3.1.2	Photocoupler Output Specifications . . . . .	3-3
3.1.3	I/O Signal Connector (CN1) Pin Arrangement . . . . .	3-4
<b>3.2</b>	<b>Settings for Triggers at Preset Positions</b> . . . . .	<b>3-5</b>
3.2.1	Setting Table Details . . . . .	3-5
3.2.2	Setting Triggers at Preset Positions . . . . .	3-7
3.2.3	Setting Trigger Outputs at Preset Positions with the SigmaWin+ . . . . .	3-9
3.2.4	Making Settings with the MEM_WR Command . . . . .	3-11
<b>3.3</b>	<b>Forced Stop Setting for Triggers at Preset Positions</b> . . . . .	<b>3-16</b>

## 4

### Rotational Coordinate System

---

<b>4.1</b>	<b>Outline</b> . . . . .	<b>4-2</b>
<b>4.2</b>	<b>Setup Procedure</b> . . . . .	<b>4-3</b>
4.2.1	Setting the Rotational Coordinate System . . . . .	4-3
4.2.2	Setting the Multiturn Limit . . . . .	4-4
4.2.3	Absolute Encoder Origin Offset . . . . .	4-4
4.2.4	Setting the Moving Method of the Rotational Coordinate System . . . . .	4-5
4.2.5	Servo Commands to Use . . . . .	4-7
4.2.6	Monitoring . . . . .	4-12

## 5

### Maintenance

---

<b>5.1</b>	<b>Alarm Displays</b> . . . . .	<b>5-2</b>
<b>5.2</b>	<b>List of Alarms</b> . . . . .	<b>5-3</b>
<b>5.3</b>	<b>Troubleshooting Alarms</b> . . . . .	<b>5-8</b>
<b>5.4</b>	<b>Warning Displays</b> . . . . .	<b>5-33</b>
<b>5.5</b>	<b>List of Warnings</b> . . . . .	<b>5-34</b>
<b>5.6</b>	<b>Troubleshooting Warnings</b> . . . . .	<b>5-36</b>
<b>5.7</b>	<b>Troubleshooting Based on the Operation and Conditions of the Servomotor</b> . . . . .	<b>5-43</b>

---

# 6

## Parameter Lists

---

<b>6.1</b>	<b>Interpreting the Parameter Lists . . . . .</b>	<b>6-2</b>
6.1.1	Interpreting the Servo Parameter List . . . . .	6-2
6.1.2	Interpreting the MECHATROLINK-III Common Parameter List . . . . .	6-2
<b>6.2</b>	<b>List of Servo Parameters . . . . .</b>	<b>6-3</b>
<b>6.3</b>	<b>List of MECHATROLINK-III Common Parameters . . . . .</b>	<b>6-40</b>

**Index**

**Revision History**

# Basic Information on SERVOPACKs

---

# 1

This chapter provides basic information, including an introduction to the product, and describes how to interpret model numbers and combinations with Servomotors.

<b>1.1</b>	<b>Product Introduction</b> .....	<b>1-2</b>
<b>1.2</b>	<b>Model Designations</b> .....	<b>1-3</b>
1.2.1	Interpreting SERVOPACK Model Numbers .....	1-3
1.2.2	Interpreting Direct Drive Servomotor Model Numbers .....	1-4
<b>1.3</b>	<b>Combinations of SERVOPACKs and Servomotors</b> ....	<b>1-5</b>
<b>1.4</b>	<b>Functions</b> .....	<b>1-6</b>
1.4.1	SERVOPACK Functions .....	1-6
1.4.2	Function Application Restrictions .....	1-8
<b>1.5</b>	<b>SigmaWin+</b> .....	<b>1-9</b>
<b>1.6</b>	<b>Combining the SERVOPACKs with MP-Series Machine Controllers and the MPE720 Engineering Tool</b> ..	<b>1-10</b>



# 1.1 Product Introduction

The SERVOPACKs described in this manual were developed to drive SGM7D motors and provide the following two functions.

Function	Description
Triggers at Preset Positions	Triggers at preset positions are signals that are output when a moving part of a machine passes a preset reference position.
Rotational Coordinate System	You can set the range of the rotational coordinate system for position data (command position (CPOS) and feedback position (APOS)) from the host controller in SERVOPACK parameters.

The SGM7D motors were designed for applications that require high torque, easy operation, and high precision. The SERVOPACK will make the most of machine performance in the shortest time possible, thus contributing to improving productivity.

# 1.2 Model Designations

## 1.2.1 Interpreting SERVOPACK Model Numbers

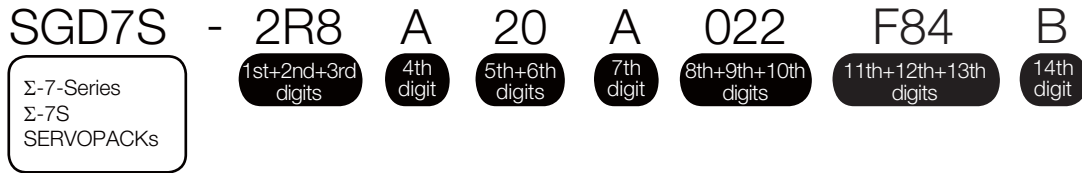

**1st+2nd+3rd digits** Maximum Applicable Motor Capacity

Voltage	Code	Specification
Three-Phase, 200 VAC	2R8*1	0.4 kW
	120*2	1.5 kW
Single-Phase, 100 VAC	2R8	0.4 kW

**4th digit** Voltage

Code	Specification
A	200 VAC
F	100 VAC

**8th+9th+10th digits** Hardware Options Specification

Code	Specification	Applicable Models
022	Without options	All models
030	Single-phase, 200-VAC power supply input	SGD7S-120A

**5th+6th digits** Interface

Code	Specification
20	MECHATROLINK-III communications references
30	MECHATROLINK-III communications references and RJ-45 connectors

**11th+12th+13th digits** FT/EX Specification

Code	Specification
F84	For transfer and alignment application with SGM7D motor

**7th digit** Design Revision Order

A
---

**14th digit** BTO Specification\*5

Code	Specification
None	None
B	BTO specification

- \*1. You can use these models with either a single-phase or three-phase input.
- \*2. A model with a single-phase, 200-VAC power supply input is available as a hardware option (model: SGD7S-120A00A008).
- \*3. The BTO specification indicates if the SEVOPACK is customized by using the MechatroCloud BTO service. You need a BTO number to order SERVOPACKs with customized specifications. Refer to the following catalog for details on the BTO specification.  
📖 AC Servo Drives Σ-7 Series (Manual No.: KAEP S800001 23)

# 1.2.2 Interpreting Direct Drive Servomotor Model Numbers

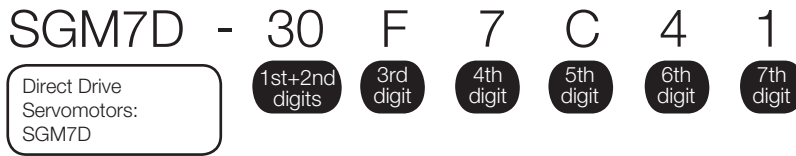

**1st+2nd digits** Rated Torque

Code	Specification	Code	Specification	Code	Specification
01	1.30 N·m	18	18.0 N·m	58	58.0 N·m
02	2.06 N·m	20	20.0 N·m	70	70.0 N·m
03	3.00 N·m	24	24.0 N·m	90	90.0 N·m
05	5.00 N·m	28	28.0 N·m	1Z	100 N·m
06	6.00 N·m	30	30.0 N·m	1A	110 N·m
08	8.00 N·m	34	34.0 N·m	1C	130 N·m
09	9.00 N·m	38	38.0 N·m	2B	220 N·m
12	12.0 N·m	45	45.0 N·m	2D	240 N·m

**3rd digit** Servomotor Outer Diameter

Code	Specification	Code	Specification
F	264-mm dia.	J	150-mm dia.
G	160-mm dia.	K	107-mm dia.
H	116-mm dia.	L	224 mm × 224 mm
I	264-mm dia.		

Note: 1. Direct Drive Servomotors are not available with holding brakes.  
 2. This information is provided to explain model numbers. It is not meant to imply that models are available for all combinations of codes.

**4th digit** Serial Encoder

Code	Specification
7	24-bit multiturn absolute encoder
F	24-bit incremental encoder

**5th digit** Design Revision Order

C

**6th digit** Flange

Code	Mounting	Servomotor Outer Diameter Code (3rd Digit)						
		F	G	H	I	J	K	L
4	Non-load side With cable on side	✓	✓	✓	-	-	-	✓
5	Non-load side With cable on bottom	✓	✓*	-	✓	✓	✓	-

✓: Applicable models.

\* SGM7D-01G and -05G are not available with a cable extending from the bottom.

**7th digit** Options

Code	Specification
1	Standard mechanical precision
2	High mechanical precision*

\* The SGM7D-01G, -05G, and -03H are available only with high mechanical precision.

## ◆ Manufactured Models

Rated Torque N·m	Servomotor Outer Diameter						
	F (264-mm dia.)	G (160-mm dia.)	H (116-mm dia.)	I (264-mm dia.)	J (150-mm dia.)	K (107-mm dia.)	L (224 mm × 224 mm)
1.30	-	SGM7D-01G	-	-	-	-	-
2.06	-	-	-	-	-	SGM7D-02K	-
3.00	-	-	SGM7D-03H	-	-	-	-
5.00	-	SGM7D-05G	-	-	-	-	-
6.00	-	-	-	-	SGM7D-06J	SGM7D-06K	SGM7D-06L
8.00	-	SGM7D-08G	-	-	-	SGM7D-08K	-
9.00	-	-	-	-	SGM7D-09J	-	-
12.0	-	-	-	-	-	-	SGM7D-12L
18.0	-	SGM7D-18G	-	-	SGM7D-18J	-	-
20.0	-	-	-	-	SGM7D-20J	-	-
24.0	-	SGM7D-24G	-	-	-	-	-
28.0	-	-	-	SGM7D-28I	-	-	-
30.0	SGM7D-30F	-	-	-	-	-	SGM7D-30L
34.0	-	SGM7D-34G	-	-	-	-	-
38.0	-	-	-	-	SGM7D-38J	-	-
45.0	-	SGM7D-45G	-	-	-	-	-
58.0	SGM7D-58F	-	-	-	-	-	-
70.0	-	-	-	SGM7D-70I	-	-	-
90.0	SGM7D-90F	-	-	-	-	-	-
100	-	-	-	SGM7D-1Zl	-	-	-
110	SGM7D-1AF	-	-	-	-	-	-
130	-	-	-	SGM7D-1Cl	-	-	-
220	-	-	-	SGM7D-2Bl	-	-	-
240	-	-	-	SGM7D-2Dl	-	-	-

Note: The above table shows combinations of the rated torque and outer diameter. The fourth through seventh digits have been omitted.

## 1.3

## Combinations of SERVOPACKs and Servomotors

Direct Drive Servomotor Model	Capacity	SERVOPACK Model
		SGD7S-
SGM7D-30F	188 W	120A
SGM7D-58F	364 W	
SGM7D-90F	565 W	
SGM7D-1AF	691 W	
SGM7D-01G	16 W	2R8A and 2R8F
SGM7D-05G	63 W	
SGM7D-08G	101 W	120A
SGM7D-18G	226 W	
SGM7D-24G	302 W	
SGM7D-34G	320 W	
SGM7D-45G	565 W	
SGM7D-03H	38 W	2R8A and 2R8F
SGM7D-28I	264 W	120A
SGM7D-70I	440 W	
SGM7D-1ZI	628 W	
SGM7D-1CI	817 W	
SGM7D-2BI	691 W	
SGM7D-2DI	754 W	
SGM7D-06J	75 W	
SGM7D-09J	113 W	
SGM7D-18J	226 W	
SGM7D-20J	251 W	
SGM7D-38J	358 W	2R8A and 2R8F
SGM7D-02K	52 W	
SGM7D-06K	151 W	
SGM7D-08K	201 W	
SGM7D-06L	113 W	120A
SGM7D-12L	226 W	
SGM7D-30L	565 W	

# 1.4 Functions

This section lists the functions provided by SERVOPACKs. Refer to the following manuals for details on the functions.

📖  $\Sigma$ -7-Series  $\Sigma$ -7S SERVOPACK with MECHATROLINK-III Communications References Product Manual (Manual No.: SIEP S800001 28)

📖  $\Sigma$ -7-Series  $\Sigma$ -7S SERVOPACK with MECHATROLINK-III Communications References and RJ-45 Connectors Product Manual (Manual No.: SIEP S800001 62)

Functions in bold boxes in the functions tables are restricted if the above SERVOPACKs are used. Refer to the following section for details on restrictions to these functions.

📖 1.4.2 Function Application Restrictions on page 1-8

## 1.4.1 SERVOPACK Functions

- Functions Related to the Machine

Functions
Power Supply Type Settings for the Main Circuit and Control Circuit
Automatic Detection of Connected Motor
Motor Direction Setting
<b>Setting the Linear Encoder Pitch</b>
<b>Writing Linear Servomotor Parameters</b>
<b>Selecting the Phase Sequence for a Linear Servomotor</b>
<b>Polarity Sensor Setting</b>
<b>Polarity Detection</b>
Overtravel Function and Settings
Holding Brake
Motor Stopping Method for Servo OFF and Alarms
Resetting the Absolute Encoder
Setting the Origin of the Absolute Encoder
Setting the Regenerative Resistor Capacity
Operation for Momentary Power Interruptions
SEMI F47 Function
Motor Maximum Speed Setting
Software Limits and Settings
Multiturn Limit Setting
Adjustment of Motor Current Detection Signal Offset
Forcing the Motor to Stop
Overheat Protection
<b>Speed Ripple Compensation</b>
Current Control Mode Selection
Current Gain Level Setting
Speed Detection Method Selection
Fully-closed Loop Control
Safety Function
External Latches
Triggers at Preset Positions
Rotational Coordinate System

- Functions Related to the Host Controller

Functions
Electronic Gear Setting
I/O Signal Allocations
ALM (Servo Alarm) Signal
/WARN (Warning) Signal
/TGON (Rotation Detection) Signal
Servo Ready Output (/S-RDY) Signal
/V-CMP (Speed Coincidence Detection) Signal
/COIN (Positioning Completion) Signal
/NEAR (Near) Signal
Speed Limit during Torque Control
/VLT (Speed Limit Detection) Signal
<b>Encoder Divided Pulse Outputs</b>
Selecting Torque Limits
Initializing the Vibration Detection Level
Resetting Alarms
Replacing the Battery
Setting the Position Deviation Overflow Alarm Level

- Functions to Achieve Optimum Motions

Functions
<b>Tuning-less Function</b>
Autotuning without Host Reference
Autotuning with a Host Reference
Custom Tuning
Anti-resonance Control Adjustment
Vibration Suppression
Gain Selection
Friction Compensation
Gravity Compensation
Backlash Compensation
Model Following Control
Compatible Adjustment Functions
Mechanical Analysis
Easy FFT

- Functions for Trial Operation during Setup

Functions
Software Reset
Trial Operation for the Servomotor without a Load
Program Jogging
Origin Searches
Test without a Motor
Monitoring Machine Operation Status and Signal Waveforms

- Functions for Inspection and Maintenance

Functions
Write Prohibition Setting for Parameters
Initializing Parameter Settings
Automatic Detection of Connected Motor
Monitoring Product Information
Monitoring Product Life
Displaying the Alarm History
Alarm Tracing

## 1.4.2 Function Application Restrictions

The following functional restrictions apply when you use the FT84 SERVOPACK.

Function	Restriction
Setting the Linear Encoder Pitch	Cannot be used.
Writing Linear Servomotor Parameters	Cannot be used.
Selecting the Phase Sequence for a Linear Servomotor	Cannot be used.
Polarity Sensor Setting	Cannot be used.
Polarity Detection	Cannot be used.
Speed Ripple Compensation	Cannot be used. Do not change the following default setting: Pn423 = n.□□□0.
Encoder Divided Pulse Outputs	Cannot be used.
Tuning-less Function	Cannot be used if the load moment of inertia ratio is 10 or greater.

## 1.5 SigmaWin+

To use the SigmaWin+, a model information file for the SERVOPACK must be added to SigmaWin+ version 7.22 or higher.

Add the FT84 model information file to SigmaWin+ to use the SigmaWin+.



## 1.6

## Combining the SERVOPACKs with MP-Series Machine Controllers and the MPE720 Engineering Tool

If you combine the SERVOPACK with an MP-Series Machine Controller or the MPE720 Engineering Tool, it will be recognized as a SERVOPACK with standard specifications. To use the parameters that have been added or changed for the SERVOPACKs described in this manual, use the SigmaWin+.

# SERVOPACK Ratings and Specifications

---

# 2

This chapter provides information required to select SERVOPACKs, such as specifications.

<b>2.1</b>	<b>Ratings</b> .....	<b>2-2</b>
2.1.1	Three-Phase, 200 VAC .....	2-2
2.1.2	Single-Phase, 200 VAC .....	2-2
2.1.3	Single-Phase, 100 VAC .....	2-3
<b>2.2</b>	<b>SERVOPACK Overload Protection Characteristics</b> ..	<b>2-4</b>
<b>2.3</b>	<b>Specifications</b> .....	<b>2-5</b>
2.3.1	SERVOPACK with MECHATROLINK-III Communications References .....	2-5
2.3.2	SERVOPACK with MECHATROLINK-III Communications References and RJ-45 Connectors .....	2-8

## 2.1 Ratings

This section gives the ratings of SERVOPACKs.

### 2.1.1 Three-Phase, 200 VAC

Model SGD7S-		2R8A	120A
Maximum Applicable Motor Capacity [kW]		0.4	1.5
Continuous Output Current [Arms]		2.8	11.6
Instantaneous Maximum Output Current [Arms]		9.3	28
Main Circuit	Power Supply	200 VAC to 240 VAC, -15% to +10%, 50 Hz/60 Hz	
	Input Current [Arms]*	2.5	7.3
Control	Power Supply	200 VAC to 240 VAC, -15% to +10%, 50 Hz/60 Hz	
	Input Current [Arms]*	0.2	0.2
Power Supply Capacity [kVA]*		1.0	3.2
Power Loss*	Main Circuit Power Loss [W]	22.5	72.6
	Control Circuit Power Loss [W]	12	15
	Built-in Regenerative Resistor Power Loss [W]	–	12
	Total Power Loss [W]	34.5	97.6
Regenerative Resistor	Built-In Regenerative Resistor	Resistance [ $\Omega$ ]	20
		Capacity [W]	60
	Minimum Allowable External Resistance [ $\Omega$ ]		40
Overvoltage Category		III	

\* This is the net value at the rated load.

### 2.1.2 Single-Phase, 200 VAC

Model SGD7S-		2R8A	120A
Maximum Applicable Motor Capacity [kW]		0.4	1.5
Continuous Output Current [Arms]		2.8	11.6
Instantaneous Maximum Output Current [Arms]		9.3	28
Main Circuit	Power Supply	200 VAC to 240 VAC, -15% to +10%, 50 Hz/60 Hz	
	Input Current [Arms]*	5.0	16
Control	Power Supply	200 VAC to 240 VAC, -15% to +10%, 50 Hz/60 Hz	
	Input Current [Arms]*	0.2	0.25
Power Supply Capacity [kVA]*		1.2	4.0
Power Loss*	Main Circuit Power Loss [W]	23.7	71.8
	Control Circuit Power Loss [W]	12	16
	Built-in Regenerative Resistor Power Loss [W]	–	12
	Total Power Loss [W]	35.7	103.8
Regenerative Resistor	Built-In Regenerative Resistor	Resistance [ $\Omega$ ]	12
		Capacity [W]	60
	Minimum Allowable External Resistance [ $\Omega$ ]		40
Overvoltage Category		III	

\* This is the net value at the rated load.

## 2.1.3 Single-Phase, 100 VAC

SGD7S-		2R8F
Maximum Applicable Motor Capacity [kW]		0.4
Continuous Output Current [Arms]		2.8
Instantaneous Maximum Output Current [Arms]		9.3
Main Circuit	Power Supply	100 VAC to 120 VAC, -15% to +10%, 50 Hz/60 Hz
	Input Current [Arms]*	10
Control	Power Supply	100 VAC to 120 VAC, -15% to +10%, 50 Hz/60 Hz
	Input Current [Arms]*	0.38
Power Supply Capacity [kVA]*		1.4
Power Loss*	Main Circuit Power Loss [W]	26.2
	Control Circuit Power Loss [W]	12
	Total Power Loss [W]	38.2
Regenerative Resistor	Minimum Allowable Resistance [ $\Omega$ ]	40
Overvoltage Category		III

\* This is the net value at the rated load.

## 2.2 SERVOPACK Overload Protection Characteristics

The overload detection level is set for hot start conditions with a SERVOPACK surrounding air temperature of 55°C.

An overload alarm (A.710 or A.720) will occur if overload operation that exceeds the overload protection characteristics shown in the following diagram (i.e., operation on the right side of the applicable line) is performed.

The actual overload detection level will be the detection level of the connected SERVOPACK or Servomotor that has the lower overload protection characteristics.

In most cases, that will be the overload protection characteristics of the Servomotor.

- SGD7S-2R8A, and -2R8F

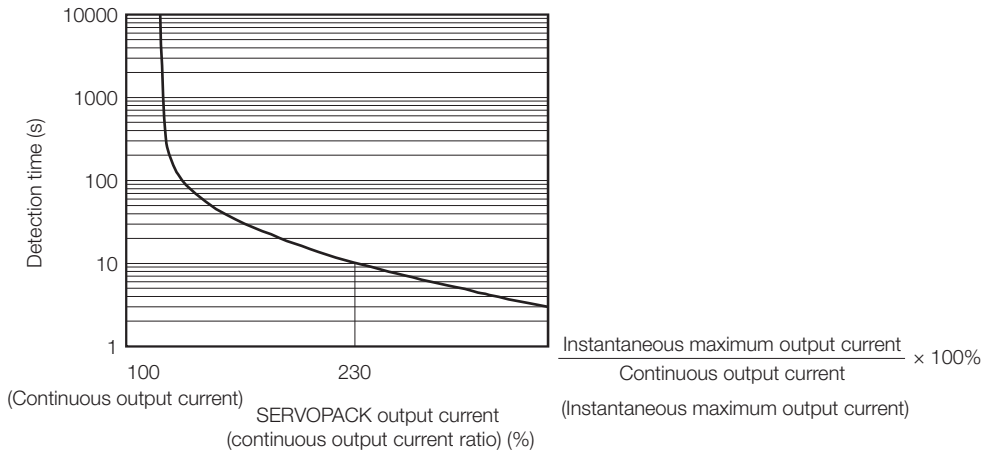

Note: The above overload protection characteristics do not mean that you can perform continuous duty operation with an output of 100% or higher. For a Yaskawa-specified combination of SERVOPACK and Servomotor, maintain the effective torque within the continuous duty zone of the torque-motor speed characteristic of the Servomotor.

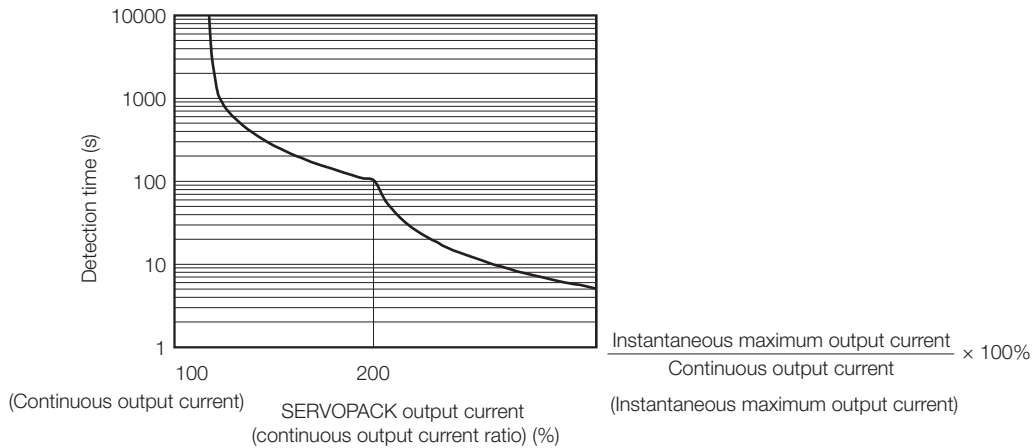

- SGD7S-120A



Note: The above overload protection characteristics do not mean that you can perform continuous duty operation with an output of 100% or higher. For a Yaskawa-specified combination of SERVOPACK and Servomotor, maintain the effective torque within the continuous duty zone of the torque-motor speed characteristic of the Servomotor.

## 2.3 Specifications

### 2.3.1 SERVOPACK with MECHATROLINK-III Communications References

Item		Specification						
Drive Method		IGBT-based PWM control, sine wave current drive						
Feedback		Serial encoder: 24 bits (incremental encoder/absolute encoder)						
Environmental Conditions	Surrounding Air Temperature* <sup>1</sup>	-5°C to 55°C (With derating, usage is possible between 55°C and 60°C.) Refer to the following manual for derating specifications.  $\Sigma$ -7-Series $\Sigma$ -7S SERVOPACK with MECHATROLINK-III Communications References Product Manual (Manual No.: SIEP S800001 28)						
	Storage Temperature	-20°C to 85°C						
	Surrounding Air Humidity	95% relative humidity max. (with no freezing or condensation)						
	Storage Humidity	95% relative humidity max. (with no freezing or condensation)						
	Vibration Resistance	4.9 m/s <sup>2</sup>						
	Shock Resistance	19.6 m/s <sup>2</sup>						
	Degree of Protection	<table border="1"> <thead> <tr> <th>Degree</th> <th>SERVOPACK Models</th> </tr> </thead> <tbody> <tr> <td>IP20</td> <td>SGD7S-2R8A, -120A (three-phase, 200-VAC input), and -2R8F</td> </tr> <tr> <td>IP10</td> <td>SGD7S-120A20A008 (single-phase, 200-VAC input)</td> </tr> </tbody> </table>	Degree	SERVOPACK Models	IP20	SGD7S-2R8A, -120A (three-phase, 200-VAC input), and -2R8F	IP10	SGD7S-120A20A008 (single-phase, 200-VAC input)
	Degree	SERVOPACK Models						
	IP20	SGD7S-2R8A, -120A (three-phase, 200-VAC input), and -2R8F						
	IP10	SGD7S-120A20A008 (single-phase, 200-VAC input)						
Pollution Degree	2 <ul style="list-style-type: none"> <li>• Must be no corrosive or flammable gases.</li> <li>• Must be no exposure to water, oil, or chemicals.</li> <li>• Must be no dust, salts, or iron dust.</li> </ul>							
Altitude* <sup>1</sup>	1,000 m max. (With derating, usage is possible between 1,000 m and 2,000 m.) Refer to the following manual for derating specifications.  $\Sigma$ -7-Series $\Sigma$ -7S SERVOPACK with MECHATROLINK-III Communications References Product Manual (Manual No.: SIEP S800001 28)							
Others	Do not use the SERVOPACK in the following locations: Locations subject to static electricity noise, strong electromagnetic/magnetic fields, or radioactivity							
Applicable Standards		Refer to the following section for details.  <i>Compliance with UL Standards, EU Directives, and Other Safety Standards on page xxvii</i>						
Mounting		Base-mounted or rack-mounted						
Performance	Speed Control Range	1:5000 (At the rated torque, the lower limit of the speed control range must not cause the Servomotor to stop.)						
	Coefficient of Speed Fluctuation* <sup>2</sup>	±0.01% of rated speed max. (for a load fluctuation of 0% to 100%)						
		0% of rated speed max. (for a load fluctuation of ±10%)						
		±0.1% of rated speed max. (for a temperature fluctuation of 25°C ±25°C)						
	Torque Control Precision (Repeatability)	±1%						
Soft Start Time Setting	0 s to 10 s (Can be set separately for acceleration and deceleration.)							

Continued on next page.

2.3 Specifications

2.3.1 SERVOPACK with MECHATROLINK-III Communications References

Continued from previous page.

Item		Specification	
I/O Signals	High-speed outputs for triggers at preset positions	Line-driver outputs	
	Overheat Protection Input	Number of input points: 1 Input voltage range: 0 V to +5 V	
	Sequence Input Signals	Input Signals That Can Be Allocated	Allowable voltage range: 24 VDC ±20% Number of input points: 7 (Input method: Sink inputs or source inputs)
			Input Signals <ul style="list-style-type: none"> <li>• /DEC (Origin Return Deceleration Switch) signal</li> <li>• /EXT1 to /EXT3 (External Latch Input 1 to 3) signals</li> <li>• P-OT (Forward Drive Prohibit) and N-OT (Reverse Drive Prohibit) signals</li> <li>• /P-CL (Forward External Torque Limit) and /N-CL (Reverse External Torque Limit) signals</li> <li>• FSTP (Forced Stop Input) signal</li> </ul> A signal can be allocated and the positive and negative logic can be changed.
	Sequence Output Signals	Fixed Output	Allowable voltage range: 5 VDC to 30 VDC Number of output points: 1 Output signal: ALM (Servo Alarm) signal
		Output Signals That Can Be Allocated	Allowable voltage range: 5 VDC to 30 VDC Number of output points: 3 (A photocoupler output (isolated) is used.)  Output Signals <ul style="list-style-type: none"> <li>• /COIN (Positioning Completion) signal</li> <li>• /V-CMP (Speed Coincidence Detection) signal</li> <li>• /TGON (Rotation Detection) signal</li> <li>• /S-RDY (Servo Ready) signal</li> <li>• /CLT (Torque Limit Detection) signal</li> <li>• /VLT (Speed Limit Detection) signal</li> <li>• /BK (Brake) signal</li> <li>• /WARN (Warning) signal</li> <li>• /NEAR (Near) signal</li> </ul> Normal output signals for triggers at preset positions A signal can be allocated and the positive and negative logic can be changed.
Communications	RS-422A Communications (CN3)	Inter- faces	Digital Operator (JUSP-OP05A-1-E) and personal computer (with SigmaWin+)
		1:N Commu- nications	Up to N = 15 stations possible for RS-422A port
		Axis Address Setting	03h to EFh (maximum number of slaves: 62) The rotary switches (S1 and S2) are used to set the station address.
	USB Communications (CN7)	Interface	Personal computer (with SigmaWin+)
Commu- nications Standard		Conforms to USB2.0 standard (12 Mbps).	
Displays/Indicators		CHARGE, PWR, CN, L1, and L2 indicators, and one-digit seven-segment display	

Continued on next page.

Continued from previous page.

Item		Specification
MECHATROLINK-III Communications	Communications Protocol	MECHATROLINK-III
	Station Address Settings	03h to EFh (maximum number of slaves: 62) The rotary switches (S1 and S2) are used to set the station address.
	Baud Rate	100 Mbps
	Transmission Cycle	125 $\mu$ s, 250 $\mu$ s, 500 $\mu$ s, 750 $\mu$ s, 1.0 ms to 4.0 ms (multiples of 0.5 ms)
	Number of Transmission Bytes	32 or 48 bytes/station A DIP switch (S3) is used to select the number of transmission bytes.
Reference Method	Performance	Position, speed, or torque control with MECHATROLINK-III communications
	Reference Input	MECHATROLINK-III commands (sequence, motion, data setting, data access, monitoring, adjustment, etc.)
	Profile	MECHATROLINK-III standard servo profile
MECHATROLINK-III Communications Setting Switches		Rotary switch (S1 and S2) positions: 16 Number of DIP switch (S3) pins: 4
Analog Monitor (CN5)		Number of points: 2 Output voltage range: $\pm 10$ VDC (effective linearity range: $\pm 8$ V) Resolution: 16 bits Accuracy: $\pm 20$ mV (Typ) Maximum output current: $\pm 10$ mA Settling time ( $\pm 1\%$ ): 1.2 ms (Typ)
Dynamic Brake (DB)		Activated when a servo alarm or overtravel (OT) occurs, or when the power supply to the main circuit or servo is OFF.
Regenerative Processing		Built-in Refer to the following catalog for details.  AC Servo Drives $\Sigma$ -7 Series (Manual No.: KAEP S800001 23)
Overtravel (OT) Prevention		Stopping with dynamic brake, deceleration to a stop, or coasting to a stop for the P-OT (Forward Drive Prohibit) or N-OT (Reverse Drive Prohibit) signal
Protective Functions		Overcurrent, overvoltage, low voltage, overload, regeneration error, etc.
Utility Functions		Gain adjustment, alarm history, jogging, origin search, etc.
Safety Functions	Inputs	/HWBB1 and /HWBB2: Base block signals for Power Modules
	Output	EDM1: Monitors the status of built-in safety circuit (fixed output).
	Applicable Standards*3	ISO13849-1 PLe (Category 3), IEC61508 SIL3
Applicable Option Modules		Fully-closed Modules and Safety Modules Note: You cannot use a Fully-closed Module and a Safety Module together.

\*1. If you combine a  $\Sigma$ -7-Series SERVOPACK with a  $\Sigma$ -V-Series Option Module, the following  $\Sigma$ -V-Series SERVO-PACKs specifications must be used: a surrounding air temperature of 0°C to 55°C and an altitude of 1,000 m max. Also, the applicable surrounding range cannot be increased by derating.



\*2. The coefficient of speed fluctuation for load fluctuation is defined as follows:

$$\text{Coefficient of speed fluctuation} = \frac{\text{No-load motor speed} - \text{Total-load motor speed}}{\text{Rated motor speed}} \times 100\%$$

\*3. Always perform risk assessment for the system and confirm that the safety requirements are met.



## 2.3.2 SERVOPACK with MECHATROLINK-III Communications References and RJ-45 Connectors

Item		Specification						
Drive Method		IGBT-based PWM control, sine wave current drive						
Feedback		Serial encoder: 24 bits (incremental encoder/absolute encoder)						
Environmental Conditions	Surrounding Air Temperature* <sup>1</sup>	-5°C to 55°C (With derating, usage is possible between 55°C and 60°C.) Refer to the following manual for derating specifications.  $\Sigma$ -7-Series $\Sigma$ -7S SERVOPACK with MECHATROLINK-III Communications References and RJ-45 Connectors Product Manual (Manual No.: SIEP S800001 62)						
	Storage Temperature	-20°C to 85°C						
	Surrounding Air Humidity	95% relative humidity max. (with no freezing or condensation)						
	Storage Humidity	95% relative humidity max. (with no freezing or condensation)						
	Vibration Resistance	4.9 m/s <sup>2</sup>						
	Shock Resistance	19.6 m/s <sup>2</sup>						
	Degree of Protection	<table border="1"> <thead> <tr> <th>Degree</th> <th>SERVOPACK Models</th> </tr> </thead> <tbody> <tr> <td>IP20</td> <td>SGD7S-2R8A, -120A (three-phase, 200-VAC input), and -2R8F</td> </tr> <tr> <td>IP10</td> <td>SGD7S-120A20A008 (single-phase, 200-VAC input)</td> </tr> </tbody> </table>	Degree	SERVOPACK Models	IP20	SGD7S-2R8A, -120A (three-phase, 200-VAC input), and -2R8F	IP10	SGD7S-120A20A008 (single-phase, 200-VAC input)
	Degree	SERVOPACK Models						
	IP20	SGD7S-2R8A, -120A (three-phase, 200-VAC input), and -2R8F						
	IP10	SGD7S-120A20A008 (single-phase, 200-VAC input)						
Pollution Degree	2 <ul style="list-style-type: none"> <li>• Must be no corrosive or flammable gases.</li> <li>• Must be no exposure to water, oil, or chemicals.</li> <li>• Must be no dust, salts, or iron dust.</li> </ul>							
Altitude* <sup>1</sup>	1,000 m max. (With derating, usage is possible between 1,000 m and 2,000 m.) Refer to the following manual for derating specifications.  $\Sigma$ -7-Series $\Sigma$ -7S SERVOPACK with MECHATROLINK-III Communications References and RJ-45 Connectors Product Manual (Manual No.: SIEP S800001 62)							
Others	Do not use the SERVOPACK in the following locations: Locations subject to static electricity noise, strong electromagnetic/magnetic fields, or radioactivity							
Applicable Standards		Refer to the following section for details.  <i>Compliance with UL Standards, EU Directives, and Other Safety Standards on page xxvii</i>						
Mounting		Base-mounted or rack-mounted						
Performance	Speed Control Range	1:5000 (At the rated torque, the lower limit of the speed control range must not cause the Servomotor to stop.)						
	Coefficient of Speed Fluctuation* <sup>2</sup>	±0.01% of rated speed max. (for a load fluctuation of 0% to 100%)						
		0% of rated speed max. (for a load fluctuation of ±10%)						
		±0.1% of rated speed max. (for a temperature fluctuation of 25°C ±25°C)						
	Torque Control Precision (Repeatability)	±1%						
Soft Start Time Setting	0 s to 10 s (Can be set separately for acceleration and deceleration.)							

Continued on next page.

2.3.2 SERVOPACK with MECHATROLINK-III Communications References and RJ-45 Connectors

Continued from previous page.

Item		Specification	
I/O Signals	High-speed outputs for triggers at preset positions	Line-driver outputs	
	Overheat Protection Input	Number of input points: 1 Input voltage range: 0 V to +5 V	
	Sequence Input Signals	Input Signals That Can Be Allocated	Allowable voltage range: 24 VDC ±20% Number of input points: 7 (Input method: Sink inputs or source inputs)
			Input Signals <ul style="list-style-type: none"> <li>• /DEC (Origin Return Deceleration Switch) signal</li> <li>• /EXT1 to /EXT3 (External Latch Input 1 to 3) signals</li> <li>• P-OT (Forward Drive Prohibit) and N-OT (Reverse Drive Prohibit) signals</li> <li>• /P-CL (Forward External Torque Limit) and /N-CL (Reverse External Torque Limit) signals</li> <li>• FSTP (Forced Stop Input) signal</li> </ul> A signal can be allocated and the positive and negative logic can be changed.
	Sequence Output Signals	Fixed Output	Allowable voltage range: 5 VDC to 30 VDC Number of output points: 1 Output signal: ALM (Servo Alarm) signal
		Output Signals That Can Be Allocated	Allowable voltage range: 5 VDC to 30 VDC Number of output points: 3 (A photocoupler output (isolated) is used.)  Output Signals <ul style="list-style-type: none"> <li>• /COIN (Positioning Completion) signal</li> <li>• /V-CMP (Speed Coincidence Detection) signal</li> <li>• /TGON (Rotation Detection) signal</li> <li>• /S-RDY (Servo Ready) signal</li> <li>• /CLT (Torque Limit Detection) signal</li> <li>• /VLT (Speed Limit Detection) signal</li> <li>• /BK (Brake) signal</li> <li>• /WARN (Warning) signal</li> <li>• /NEAR (Near) signal</li> <li>• Normal output signals for triggers at preset positions</li> </ul> A signal can be allocated and the positive and negative logic can be changed.
Communi- cations	RS-422A Communi- cations (CN502)	Inter- faces	Digital Operator (JUSP-OP05A-1-E) A JUSP-JC001 Communications Unit is required to connect a Digital Operator.
		1:N Communi- cations	Up to N = 15 stations possible for RS-422A port
		Axis Address Setting	03h to EFh (maximum number of slaves: 62) The rotary switches (S1 and S2) are used to set the station address.
	USB Communi- cations (CN7)	Interface	Personal computer (with SigmaWin+)
Communi- cations Standard		Conforms to USB2.0 standard (12 Mbps).	
Displays/Indicators		CHARGE, PWR, CN, L1, and L2 indicators, and one-digit seven-seg- ment display	

Continued on next page.

## 2.3 Specifications

### 2.3.2 SERVOPACK with MECHATROLINK-III Communications References and RJ-45 Connectors

Continued from previous page.

Item		Specification
MECHATROLINK-III Communications	Communications Protocol	MECHATROLINK-III
	Station Address Settings	03h to EFh (maximum number of slaves: 62) The rotary switches (S1 and S2) are used to set the station address.
	Baud Rate	100 Mbps
	Transmission Cycle	125 μs, 250 μs, 500 μs, 750 μs, 1.0 ms to 4.0 ms (multiples of 0.5 ms)
	Number of Transmission Bytes	32 or 48 bytes/station A DIP switch (S3) is used to select the number of transmission bytes.
Reference Method	Performance	Position, speed, or torque control with MECHATROLINK-III communications
	Reference Input	MECHATROLINK-III commands (sequence, motion, data setting, data access, monitoring, adjustment, etc.)
	Profile	MECHATROLINK-III standard servo profile
MECHATROLINK-III Communications Setting Switches		Rotary switch (S1 and S2) positions: 16
		Number of DIP switch (S3) pins: 4
Analog Monitor (CN5)		Number of points: 2 Output voltage range: ±10 VDC (effective linearity range: ±8 V) Resolution: 16 bits Accuracy: ±20 mV (Typ) Maximum output current: ±10 mA Settling time (±1%): 1.2 ms (Typ)
Dynamic Brake (DB)		Activated when a servo alarm or overtravel (OT) occurs, or when the power supply to the main circuit or servo is OFF.
Regenerative Processing		Built-in Refer to the following catalog for details.  $\Sigma$ -7 Series Peripheral Device Selection Manual (Manual No.: SIEP S800001 32)
Overtravel (OT) Prevention		Stopping with dynamic brake, deceleration to a stop, or coasting to a stop for the P-OT (Forward Drive Prohibit) or N-OT (Reverse Drive Prohibit) signal
Protective Functions		Overcurrent, overvoltage, low voltage, overload, regeneration error, etc.
Utility Functions		Gain adjustment, alarm history, jogging, origin search, etc.
Safety Functions	Inputs	/HWBB1 and /HWBB2: Base block signals for Power Modules
	Output	EDM1: Monitors the status of built-in safety circuit (fixed output).
	Applicable Standards*3	ISO13849-1 PLe (Category 3), IEC61508 SIL3
Applicable Option Modules		Fully-closed Modules and Safety Modules Note: You cannot use a Fully-closed Module and a Safety Module together.

\*1. If you combine a  $\Sigma$ -7-Series SERVOPACK with a  $\Sigma$ -V-Series Option Module, the following  $\Sigma$ -V-Series SERVO-PACKs specifications must be used: a surrounding air temperature of 0°C to 55°C and an altitude of 1,000 m max. Also, the applicable surrounding range cannot be increased by derating.

\*2. The coefficient of speed fluctuation for load fluctuation is defined as follows:

$$\text{Coefficient of speed fluctuation} = \frac{\text{No-load motor speed} - \text{Total-load motor speed}}{\text{Rated motor speed}} \times 100\%$$

\*3. Always perform risk assessment for the system and confirm that the safety requirements are met.

# Triggers at Preset Positions

# 3

This chapter describes triggers at preset positions.

<b>3.1</b>	<b>Outline</b> . . . . .	<b>3-2</b>
3.1.1	Line-Driver Output Specifications . . . . .	3-3
3.1.2	Photocoupler Output Specifications . . . . .	3-3
3.1.3	I/O Signal Connector (CN1) Pin Arrangement . . .	3-4
<b>3.2</b>	<b>Settings for Triggers at Preset Positions</b> . .	<b>3-5</b>
3.2.1	Setting Table Details . . . . .	3-5
3.2.2	Setting Triggers at Preset Positions . . . . .	3-7
3.2.3	Setting Trigger Outputs at Preset Positions with the SigmaWin+ . . . . .	3-9
3.2.4	Making Settings with the MEM_WR Command . .	3-11
<b>3.3</b>	<b>Forced Stop Setting for Triggers at Preset Positions</b> . .	<b>3-16</b>

# 3.1 Outline

Triggers at preset positions are signals that are output when a moving part of a machine passes preset reference positions. You can use this function to set signal outputs for up to 32 positions.

The following image shows the operation of triggers at preset positions.

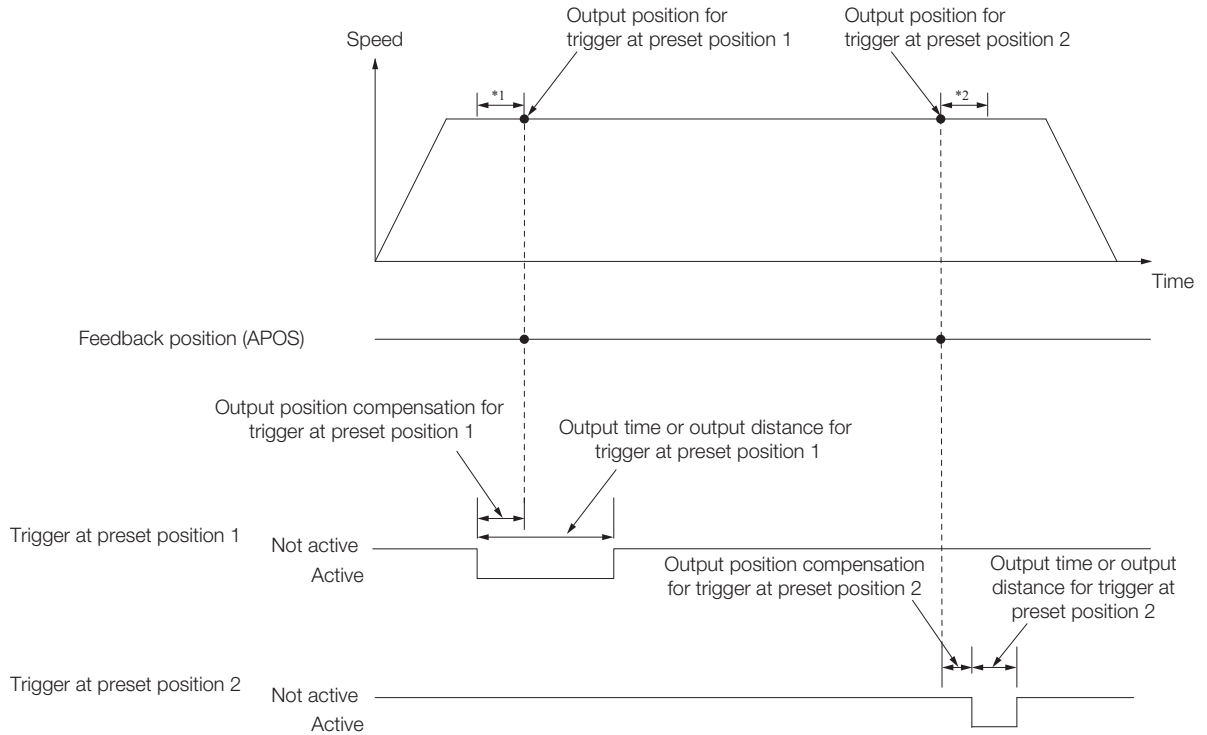

- \*1. For triggers at preset positions to function, the speed must be constant for at least 250  $\mu$ s before the machine passes a preset position.
- \*2. When you set the output width of a signal output at a preset position as a distance, use a distance that does not exceed the point where deceleration of the constant speed starts.



Important

Triggers at preset positions are enabled by performing one of the following steps.

**Absolute Encoder**  
Send the Turn Sensor ON command (SENS\_ON: 23h) from the host controller.

**Incremental Encoder**

- Send the Zero Point Return command (ZRET: 3Ah) from the host controller.
- Use the Set Coordinates command (POS\_SET: 20h) from the host controller to set a reference point (REFE = 1).
- If you use triggers at preset positions when the rotational coordinate system is enabled (i.e., Pn87A or Pn87C is not set to 0), set the output position so that it falls between Pn87C (First Rotational Coordinate) and Pn87A (Last Rotational Coordinate). Refer to the following chapter for details on the rotational coordinate system.

 [Chapter 4 Rotational Coordinate System](#)

You can use both high-speed outputs that output signals from line drivers and normal outputs that output signals from photocouplers for triggers at preset positions. They can also be used together.

Output circuit specifications for the line-driver and photocoupler output are given below.

## 3.1.1 Line-Driver Output Specifications

Compared with a photocoupler, a line driver is capable of more precise output, and it is suitable for applications with no margin for output signal delays or variations.

Item	Specification
Number of Output Position Settings	32 positions
Range of Output Position Settings	-2,147,483,648 to 2,147,483,647 reference units
Outputs for Triggers at Preset Positions	Triggers at preset positions are allocated to output signals /HSO1 and /HSO2 on CN1.
Output Time Setting Range	0 to 32,767,000 $\mu$ s
Output Distance Setting Range	0 to 4,294,967,295 reference units
Output Position Compensation Range	-2,147,483,648 to 2,147,483,647 reference units
Signal Output Delay Time	ON to OFF: 1 $\mu$ s or less, OFF to ON: 1 $\mu$ s or less
Signal Output Variation	At constant speed of 50 $\text{min}^{-1}$ or greater: 5 $\mu$ s max.*

\* The accuracy of high-speed signal outputs for triggers at preset positions is reduced during acceleration or deceleration.

## 3.1.2 Photocoupler Output Specifications

Item	Specification
Number of Output Position Settings	32 positions
Range of Output Position Settings	-2,147,483,648 to 2,147,483,647 reference units
Outputs for Triggers at Preset Positions	Triggers at preset positions are allocated to output signals /SO1, /SO2, and /SO3 on CN1.
Output Time Setting Range	0 to 65,535 ms
Output Distance Setting Range	0 to 4,294,967,295 reference units
Output Position Compensation Range	-2,147,483,648 to 2,147,483,647 reference units
Signal Output Delay Time	ON to OFF: 2 ms or less, OFF to ON: 1 ms or less
Signal Output Variation	125 $\mu$ s max.

### 3.1.3 I/O Signal Connector (CN1) Pin Arrangement

The following figure gives the pin arrangement of the of the I/O signal connector (CN1) for the default settings.

When you use line-driver high-speed outputs, wire the outputs to CN1-17 and CN1-18 and to CN1-21 and CN1-22. When you use photocoupler normal outputs, allocate the output signals for triggers at preset positions as normal and wire the outputs to CN1-1 and CN1-2, CN1-23 and CN1-24, or CN1-25 and CN1-26.

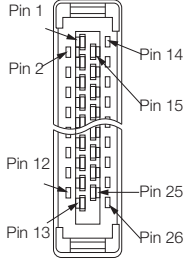

The above view is from the direction of the following arrow without the connector shell attached.

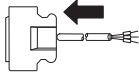

2	/SO1- (/BK-)	General-Purpose Sequence Output 1	1	/SO1+ (/BK+)	General-Purpose Sequence Output 1	15	BAT-	Battery for Absolute Encoder (-)	14	BAT+	Battery for Absolute Encoder (+)
4	ALM-	Servo Alarm Output	3	ALM+	Servo Alarm Output	17	HSO1	High-Speed Preset Position Output 1	16	SG	Signal Ground
6	+24VIN	Sequence Input Signal Power Supply Input	5	TH	Linear Servomotor Overheat Protection Input	19	-	-	18	/HSO1	High-Speed Preset Position Output 1
8	/SI2 (N-OT)	General-Purpose Sequence Input 2	7	/SI1 (P-OT)	General-Purpose Sequence Input 1	21	HSO2	High-Speed Preset Position Output 2	20	-	-
10	/SI4 (/EXT1)	General-Purpose Sequence Input 4	9	/SI3 (/DEC)	General-Purpose Sequence Input 3	23	/SO2+	General-Purpose Sequence Output 2	22	/HSO2	High-Speed Preset Position Output 2
12	/SI6 (/EXT3)	General-Purpose Sequence Input 6	11	/SI5 (/EXT2)	General-Purpose Sequence Input 5	25	/SO3+	General-Purpose Sequence Output 3	24	/SO2-	General-Purpose Sequence Output 2
			13	/SI0	General-Purpose Sequence Input 0				26	/SO3-	General-Purpose Sequence Output 3

## 3.2 Settings for Triggers at Preset Positions

You can output triggers at preset positions with the SigmaWin+ or with MEM\_WR commands based on the following setting table. There are two types of setting tables: one for high-speed outputs from line drivers and one for normal outputs from photocouplers.

### 3.2.1 Setting Table Details

This section gives details on setting tables.

	①	②	③	④	⑤
Name	Output Position	Output Function	Output Time	Output Distance	Output Position Compensation
Output Setting 1					
Output Setting 2					
Output Setting 3					
⋮					
Output Setting 32					

#### ① Output Position

Set the reference position for outputting a signal for the trigger at the preset position.

Size	Setting Range	Setting Unit	Default Setting	When Enabled	Classification
4	-2,147,483,648 to 2,147,483,647	Reference units	0	Immediately	Setup

#### ② Output Function

Select the axis number, output terminals, signal logic, and passing direction to use for the trigger at the preset position.

Size	Setting Range	Setting Unit	Default Setting	When Enabled	Classification
4	00000000h to 000012A1h	–	00000000h	–	Setup

Digit	Name	Setting	Description
0	Axis No.*1	0	Set the axis number. For an SGD7S SERVOPACK, set the axis number to 0.

Continued on next page.



## 3.2 Settings for Triggers at Preset Positions

### 3.2.1 Setting Table Details

Continued from previous page.

Digit	Name	Setting	Description
1	Output Terminals and Signal Logic* <sup>1</sup> (High-Speed Output Settings)	0	Disable. (The signal is not output.)
		1	Output the signal from the CN1-17 and CN1-18 output terminals.
		2	Output the signal from the CN1-21 and CN1-22 output terminals.
		3	Output the reverse signal from the CN1-17 and CN1-18 output terminals.
		4	Output the reverse signal from the CN1-21 and CN1-22 output terminals.
		5 to A	Disable. (The signal is not output.)
	Output Terminals and Signal Logic* <sup>1</sup> (Normal Output Settings)	0	Disable. (The signal is not output.)
		1	Output the signal from the CN1-1 and CN1-2 output terminals.
		2	Output the signal from the CN1-23 and CN1-24 output terminals.
		3	Output the signal from the CN1-25 and CN1-26 output terminals.
		4	Disable. (The signal is not output.)
		5	Disable. (The signal is not output.)
		6	Output the reverse signal from the CN1-1 and CN1-2 output terminals.
		7	Output the reverse signal from the CN1-23 and CN1-24 output terminals.
2	Passing Direction* <sup>2</sup>	0	Output the signal at the preset position during forward movement.
		1	Output the signal at the preset position during reverse movement.
		2	Output the signal at the preset position during forward or reverse movement.
3 to 7	Reserved (Do not use.)		

\*1. The selected axis number, output terminals, and signal logic are enabled after the power supply is turned OFF and ON again or after the Setup Device command (CONFIG) is sent from the host controller.

\*2. The passing direction is enabled immediately after it is changed.

#### ③ Output Time

Set the output time of the preset position signal output.

##### • High-Speed Output Settings

Size	Setting Range	Setting Unit	Default Setting	When Enabled	Classification
4	0 to 32,767,000	1 μs	0	Immediately	Setup

##### • Normal Output Settings

Size	Setting Range	Setting Unit	Default Setting	When Enabled	Classification
4	0 to 65,535	1 ms	0	Immediately	Setup

#### ④ Output Distance

Set the output width of the present position signal output as a distance.

Size	Setting Range	Setting Unit	Default Setting	When Enabled	Classification
4	0 to 4,294,967,295	Reference units	0	Immediately	Setup

### ⑤ Output Position Compensation

Set the compensation distance in reference units from the reference position set in the output position setting.

Size	Setting Range	Setting Unit	Default Setting	When Enabled	Classification
4	-2,147,483,648 to 2,147,483,647	Reference units	0	Immediately	Setup



Important

1. The polarity for signals output at preset positions can also be reversed with Pn512 (Output Signal Inverse settings). Always check the setting of Pn512 before you allocate signal outputs at preset positions.
2. If different signal logics are assigned to the same output terminals, the logic that is set for the trigger at a preset position with the smallest number will be given priority.
3. If you set the output distance in reference units for the output function, make sure the output distance is within the following distances.
  - If you use triggers at preset positions in combination with a rotational coordinate system, set the output distance to between Pn87C and Pn87A.
  - If you use triggers at preset positions but do not use a rotational coordinate system, set the output distance to between -2,147,483,648 and 2,147,483,647.
 If you set the output distance to a value that exceeds the above ranges, an A.042 (Parameter Combination Error) alarm will occur.

## 3.2.2 Setting Triggers at Preset Positions

This section describes the method to use the MEM\_WR command to set high-speed outputs from line drivers or normal outputs from photocouplers.

### High-Speed Output Setting Method

This section describes the procedure to execute high-speed outputs with the MEM\_WR command.

Step	Operation
1	Set the output positions in reference units.
2	Set the axis numbers, output signal allocations, and passing directions with the output function selection.
3	If Pn660 is set to n.□□0□, set the signal output width as a time in $\mu$ s. If Pn660 is set to n.□□1□, set the signal output width as a distance in reference units.
4	If Pn660 is set to n.□□0□, set the output time in $\mu$ s. If Pn660 is set to n.□□1□, set the output distance as a distance in reference units.
5	Set the output position compensation as a distance in reference units.
6	Send the Setup Device command (CONFIG) to the SERVOPACK from the host controller. The settings in the High-Speed Output Settings will be enabled.
7	Send the Turn Sensor ON command (SENS_ON: 23h) from the host controller to obtain the position data. Note: If you use an incremental encoder, the following step must also be performed. Send the Zero Point Return command (ZRET: 3Ah) from the host controller, or use the Set Coordinates command (POS_SET: 20h) to set REFE to 1.
8	Turn ON the servo, and send the motion command. When the moving part of the machine passes a preset position, a high-speed output signal is output.

You can make the settings for steps 1, 2, 4, and 5 from the SigmaWin+ or by executing the MEM\_WR command.

Refer to the following sections for details on the settings and then make the settings.

3.2.3 Setting Trigger Outputs at Preset Positions with the SigmaWin+ on page 3-9

3.2.4 Making Settings with the MEM\_WR Command on page 3-11

## Normal Output Setting Method

This section describes the procedure to execute normal outputs with the MEM\_WR command.

Step	Operation
1	Set the following output signal selections 1 to 4. <ul style="list-style-type: none"> <li>• Pn50E (Output Signal Selections 1)</li> <li>• Pn50F (Output Signal Selections 2)</li> <li>• Pn510 (Output Signal Selections 3)</li> <li>• Pn514 (Output Signal Selections 4)</li> </ul>
2	Set the output position in reference units.
3	Set the axis number, output signal allocation, and passing direction with the output function selection.
4	If Pn660 is set to n.□□0□, set the signal output width as a time in ms. If Pn660 is set to n.□□1□, set the signal output width as a distance in reference units.
5	If Pn660 is set to n.□□0□, set the output time in ms. If Pn660 is set to n.□□1□, set the output distance as a distance in reference units.
6	Set the output position compensation as a distance in reference units.
7	Send the Setup Device command (CONFIG) to the SERVOPACK from the host controller. The settings in the Normal Output Settings will be enabled.
8	Send the Turn Sensor ON command (SENS_ON: 23h) from the host controller to obtain the position data. Note: If you use an incremental encoder, the following step must also be performed. Send the Zero Point Return command (ZRET: 3Ah) from the host controller, or use the Set Coordinates command (POS_SET: 20h) to set REFE to 1.
9	Turn ON the servo, and send the motion command. When the moving part of the machine passes a preset position, a normal output signal is output.

You can make the settings for steps 2, 3, 5, and 6 from the SigmaWin+ or by executing the MEM\_WR command.

Refer to the following sections for details on the settings and then make the settings.

 3.2.3 Setting Trigger Outputs at Preset Positions with the SigmaWin+ on page 3-9

 3.2.4 Making Settings with the MEM\_WR Command on page 3-11

## 3.2.3 Setting Trigger Outputs at Preset Positions with the SigmaWin+

This section provides the setting procedure to execute triggers at preset positions from the SigmaWin+.

The flow of operation from making settings for triggers at preset positions through writing data to the SERVOPACK is described. Refer to the following manual for details on editing tables on the SigmaWin+.

📖 AC Servo Drive Engineering Tool SigmaWin+ Operation Manual (Manual No.: SIET S800001 34)

1. Click the  **Servo Drive Button** in the workspace of the Main Window of the SigmaWin+.
2. Select **Set Triggers at Preset Positions** in Table Program.

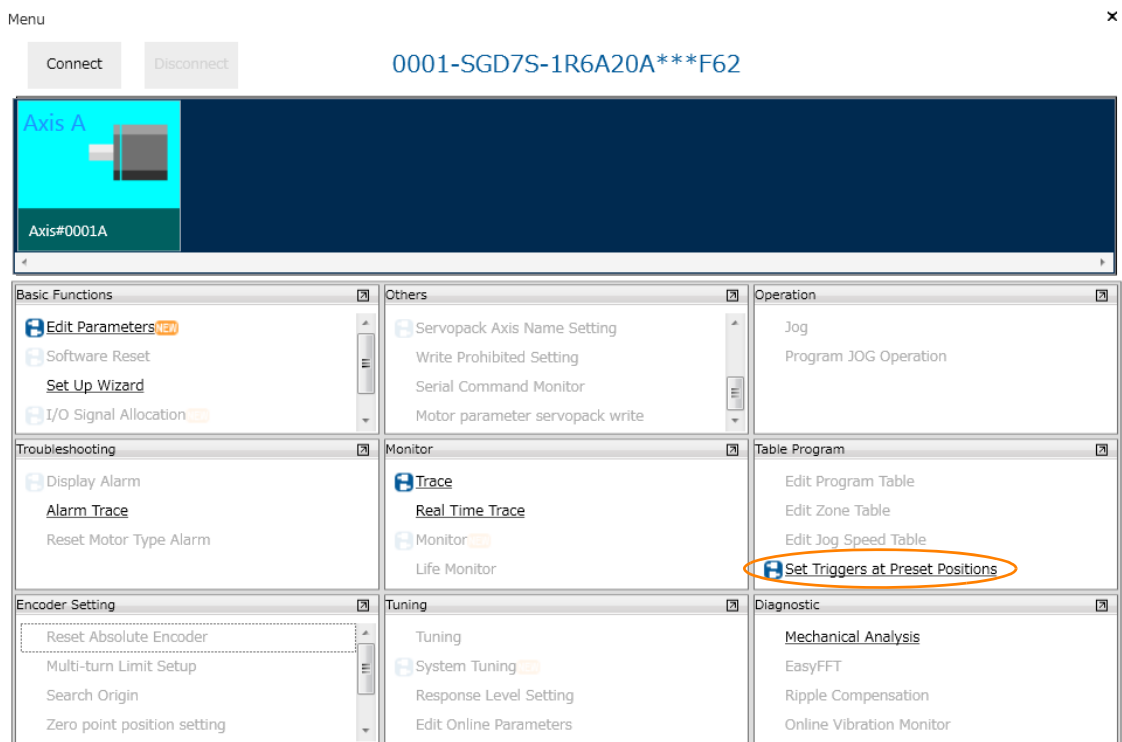

**Information** If you use SigmaWin+ version 7.22 or earlier, Set Trigger at Preset Positions is displayed in Diagnostic, not in Table Program.

The Set Triggers at Preset Positions Dialog Box will be displayed.

3.2 Settings for Triggers at Preset Positions

3.2.3 Setting Trigger Outputs at Preset Positions with the SigmaWin+

3. Click the **High-Speed Output Settings** Tab.

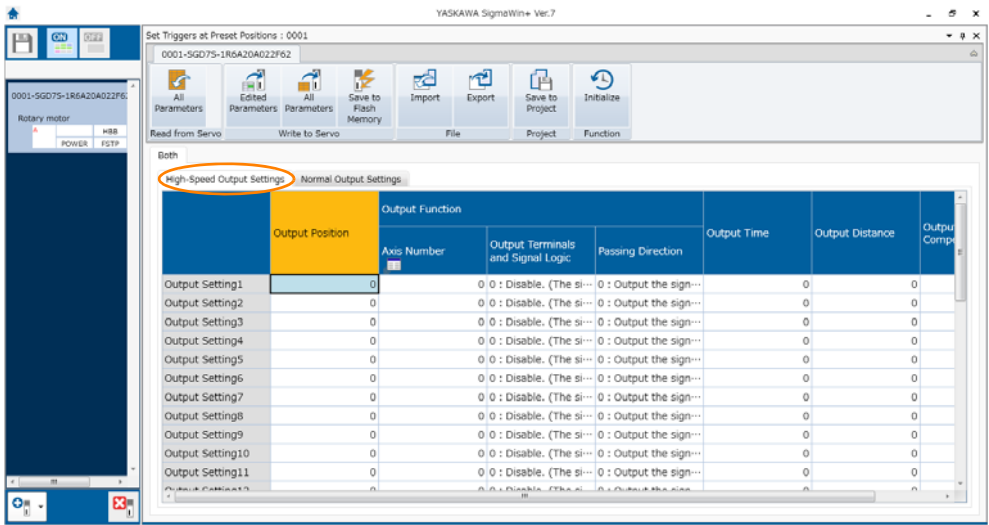

**Information** If the **Normal Output Settings** Tab is clicked, the following dialog box will be displayed.

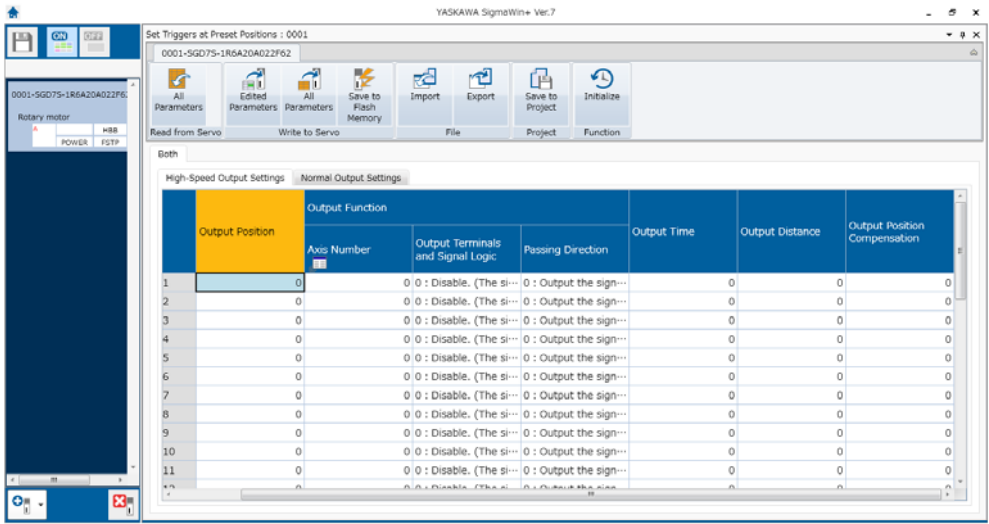

4. Set the items for the Output Setting 1 to 32 to use.

Refer to the following section for details on the settings of the items.

3.2.1 Setting Table Details on page 3-5

5. After the settings are completed, click the **All Parameters** Button.

The edited data will be written to the volatile memory in the SERVOPACK.

6. Click the **Save to Flash Memory** Button.

The edited data will be written to the non-volatile memory in the SERVOPACK.

Note: When you write edited data to the SERVOPACK, you must save it to flash memory. If the data is not saved to flash memory, the edited data will be erased from memory when the power supply to the SERVOPACK is turned OFF.

This concludes the procedure to set up triggers at preset positions.

## 3.2.4 Making Settings with the MEM\_WR Command

### High-Speed Output Settings

When you set the high-speed outputs with the MEM\_WR command, set the parameters based on the following table.

Name	Output Position	Output Function	Output Time	Output Distance	Output Position Compensation	Reserved	Reserved	Reserved
Output Setting 1	0xF0050000	0xF0050004	0xF0050008	0xF005000C	0xF0050010	0xF0050014	0xF0050018	0xF005001C
Output Setting 2	0xF0050020	0xF0050024	0xF0050028	0xF005002C	0xF0050030	0xF0050034	0xF0050038	0xF005003C
Output Setting 3	0xF0050040	0xF0050044	0xF0050048	0xF005004C	0xF0050050	0xF0050054	0xF0050058	0xF005005C
Output Setting 4	0xF0050060	0xF0050064	0xF0050068	0xF005006C	0xF0050070	0xF0050074	0xF0050078	0xF005007C
Output Setting 5	0xF0050080	0xF0050084	0xF0050088	0xF005008C	0xF0050090	0xF0050094	0xF0050098	0xF005009C
Output Setting 6	0xF00500A0	0xF00500A4	0xF00500A8	0xF00500AC	0xF00500B0	0xF00500B4	0xF00500B8	0xF00500BC
Output Setting 7	0xF00500C0	0xF00500C4	0xF00500C8	0xF00500CC	0xF00500D0	0xF00500D4	0xF00500D8	0xF00500DC
Output Setting 8	0xF00500E0	0xF00500E4	0xF00500E8	0xF00500EC	0xF00500F0	0xF00500F4	0xF00500F8	0xF00500FC
Output Setting 9	0xF0050100	0xF0050104	0xF0050108	0xF005010C	0xF0050110	0xF0050114	0xF0050118	0xF005011C
Output Setting 10	0xF0050120	0xF0050124	0xF0050128	0xF005012C	0xF0050130	0xF0050134	0xF0050138	0xF005013C
Output Setting 11	0xF0050140	0xF0050144	0xF0050148	0xF005014C	0xF0050150	0xF0050154	0xF0050158	0xF005015C
Output Setting 12	0xF0050160	0xF0050164	0xF0050168	0xF005016C	0xF0050170	0xF0050174	0xF0050178	0xF005017C
Output Setting 13	0xF0050180	0xF0050184	0xF0050188	0xF005018C	0xF0050190	0xF0050194	0xF0050198	0xF005019C
Output Setting 14	0xF00501A0	0xF00501A4	0xF00501A8	0xF00501AC	0xF00501B0	0xF00501B4	0xF00501B8	0xF00501BC
Output Setting 15	0xF00501C0	0xF00501C4	0xF00501C8	0xF00501CC	0xF00501D0	0xF00501D4	0xF00501D8	0xF00501DC
Output Setting 16	0xF00501E0	0xF00501E4	0xF00501E8	0xF00501EC	0xF00501F0	0xF00501F4	0xF00501F8	0xF00501FC
Output Setting 17	0xF0050200	0xF0050204	0xF0050208	0xF005020C	0xF0050210	0xF0050214	0xF0050218	0xF005021C
Output Setting 18	0xF0050220	0xF0050224	0xF0050228	0xF005022C	0xF0050230	0xF0050234	0xF0050238	0xF005023C
Output Setting 19	0xF0050240	0xF0050244	0xF0050248	0xF005024C	0xF0050250	0xF0050254	0xF0050258	0xF005025C
Output Setting 20	0xF0050260	0xF0050264	0xF0050268	0xF005026C	0xF0050270	0xF0050274	0xF0050278	0xF005027C
Output Setting 21	0xF0050280	0xF0050284	0xF0050288	0xF005028C	0xF0050290	0xF0050294	0xF0050298	0xF005029C
Output Setting 22	0xF00502A0	0xF00502A4	0xF00502A8	0xF00502AC	0xF00502B0	0xF00502B4	0xF00502B8	0xF00502BC
Output Setting 23	0xF00502C0	0xF00502C4	0xF00502C8	0xF00502CC	0xF00502D0	0xF00502D4	0xF00502D8	0xF00502DC
Output Setting 24	0xF00502E0	0xF00502E4	0xF00502E8	0xF00502EC	0xF00502F0	0xF00502F4	0xF00502F8	0xF00502FC
Output Setting 25	0xF0050300	0xF0050304	0xF0050308	0xF005030C	0xF0050310	0xF0050314	0xF0050318	0xF005031C
Output Setting 26	0xF0050320	0xF0050324	0xF0050328	0xF005032C	0xF0050330	0xF0050334	0xF0050338	0xF005033C
Output Setting 27	0xF0050340	0xF0050344	0xF0050348	0xF005034C	0xF0050350	0xF0050354	0xF0050358	0xF005035C
Output Setting 28	0xF0050360	0xF0050364	0xF0050368	0xF005036C	0xF0050370	0xF0050374	0xF0050378	0xF005037C
Output Setting 29	0xF0050380	0xF0050384	0xF0050388	0xF005038C	0xF0050390	0xF0050394	0xF0050398	0xF005039C
Output Setting 30	0xF00503A0	0xF00503A4	0xF00503A8	0xF00503AC	0xF00503B0	0xF00503B4	0xF00503B8	0xF00503BC
Output Setting 31	0xF00503C0	0xF00503C4	0xF00503C8	0xF00503CC	0xF00503D0	0xF00503D4	0xF00503D8	0xF00503DC
Output Setting 32	0xF00503E0	0xF00503E4	0xF00503E8	0xF00503EC	0xF00503F0	0xF00503F4	0xF00503F8	0xF00503FC



## Normal Output Settings

When you set the normal outputs with the MEM\_WR command, set the parameters based on the following table.

Name	Output Position	Output Function	Output Time	Output Distance	Output Position Compensation	Reserved	Reserved	Reserved
Output Setting 1	0xF0050400	0xF0050404	0xF0050408	0xF005040C	0xF0050410	0xF0050414	0xF0050418	0xF005041C
Output Setting 2	0xF0050420	0xF0050424	0xF0050428	0xF005042C	0xF0050430	0xF0050434	0xF0050438	0xF005043C
Output Setting 3	0xF0050440	0xF0050444	0xF0050448	0xF005044C	0xF0050450	0xF0050454	0xF0050458	0xF005045C
Output Setting 4	0xF0050460	0xF0050464	0xF0050468	0xF005046C	0xF0050470	0xF0050474	0xF0050478	0xF005047C
Output Setting 5	0xF0050480	0xF0050484	0xF0050488	0xF005048C	0xF0050490	0xF0050494	0xF0050498	0xF005049C
Output Setting 6	0xF00504A0	0xF00504A4	0xF00504A8	0xF00504AC	0xF00504B0	0xF00504B4	0xF00504B8	0xF00504BC
Output Setting 7	0xF00504C0	0xF00504C4	0xF00504C8	0xF00504CC	0xF00504D0	0xF00504D4	0xF00504D8	0xF00504DC
Output Setting 8	0xF00504E0	0xF00504E4	0xF00504E8	0xF00504EC	0xF00504F0	0xF00504F4	0xF00504F8	0xF00504FC
Output Setting 9	0xF0050500	0xF0050504	0xF0050508	0xF005050C	0xF0050510	0xF0050514	0xF0050518	0xF005051C
Output Setting 10	0xF0050520	0xF0050524	0xF0050528	0xF005052C	0xF0050530	0xF0050534	0xF0050538	0xF005053C
Output Setting 11	0xF0050540	0xF0050544	0xF0050548	0xF005054C	0xF0050550	0xF0050554	0xF0050558	0xF005055C
Output Setting 12	0xF0050560	0xF0050564	0xF0050568	0xF005056C	0xF0050570	0xF0050574	0xF0050578	0xF005057C
Output Setting 13	0xF0050580	0xF0050584	0xF0050588	0xF005058C	0xF0050590	0xF0050594	0xF0050598	0xF005059C
Output Setting 14	0xF00505A0	0xF00505A4	0xF00505A8	0xF00505AC	0xF00505B0	0xF00505B4	0xF00505B8	0xF00505BC
Output Setting 15	0xF00505C0	0xF00505C4	0xF00505C8	0xF00505CC	0xF00505D0	0xF00505D4	0xF00505D8	0xF00505DC
Output Setting 16	0xF00505E0	0xF00505E4	0xF00505E8	0xF00505EC	0xF00505F0	0xF00505F4	0xF00505F8	0xF00505FC
Output Setting 17	0xF0050600	0xF0050604	0xF0050608	0xF005060C	0xF0050610	0xF0050614	0xF0050618	0xF005061C
Output Setting 18	0xF0050620	0xF0050624	0xF0050628	0xF005062C	0xF0050630	0xF0050634	0xF0050638	0xF005063C
Output Setting 19	0xF0050640	0xF0050644	0xF0050648	0xF005064C	0xF0050650	0xF0050654	0xF0050658	0xF005065C
Output Setting 20	0xF0050660	0xF0050664	0xF0050668	0xF005066C	0xF0050670	0xF0050674	0xF0050678	0xF005067C
Output Setting 21	0xF0050680	0xF0050684	0xF0050688	0xF005068C	0xF0050690	0xF0050694	0xF0050698	0xF005069C
Output Setting 22	0xF00506A0	0xF00506A4	0xF00506A8	0xF00506AC	0xF00506B0	0xF00506B4	0xF00506B8	0xF00506BC
Output Setting 23	0xF00506C0	0xF00506C4	0xF00506C8	0xF00506CC	0xF00506D0	0xF00506D4	0xF00506D8	0xF00506DC
Output Setting 24	0xF00506E0	0xF00506E4	0xF00506E8	0xF00506EC	0xF00506F0	0xF00506F4	0xF00506F8	0xF00506FC
Output Setting 25	0xF0050700	0xF0050704	0xF0050708	0xF005070C	0xF0050710	0xF0050714	0xF0050718	0xF005071C
Output Setting 26	0xF0050720	0xF0050724	0xF0050728	0xF005072C	0xF0050730	0xF0050734	0xF0050738	0xF005073C
Output Setting 27	0xF0050740	0xF0050744	0xF0050748	0xF005074C	0xF0050750	0xF0050754	0xF0050758	0xF005075C
Output Setting 28	0xF0050760	0xF0050764	0xF0050768	0xF005076C	0xF0050770	0xF0050774	0xF0050778	0xF005077C
Output Setting 29	0xF0050780	0xF0050784	0xF0050788	0xF005078C	0xF0050790	0xF0050794	0xF0050798	0xF005079C
Output Setting 30	0xF00507A0	0xF00507A4	0xF00507A8	0xF00507AC	0xF00507B0	0xF00507B4	0xF00507B8	0xF00507BC
Output Setting 31	0xF00507C0	0xF00507C4	0xF00507C8	0xF00507CC	0xF00507D0	0xF00507D4	0xF00507D8	0xF00507DC
Output Setting 32	0xF00507E0	0xF00507E4	0xF00507E8	0xF00507EC	0xF00507F0	0xF00507F4	0xF00507F8	0xF00507FC

## Setting Details for the Write Memory (MEM\_WR: 1Eh) Command

### ◆ Data Format

Phases in which the Command can be Executed		2, 3	Command Classification	Common command	Asynchronous command
Processing Time		 $\Sigma$ -7-Series MECHATROLINK-III Communications Standard Servo Profile Command Manual (Manual No.: SIEP S800001 31)	Subcommand	Cannot be used	
Byte	MEM_WR		Description		
	Command	Response			
0	1Eh	1Eh	<ul style="list-style-type: none"> <li>The MEM_WR command writes the data in virtual memory by specifying the initial address, the data size and the data for writing.</li> <li>This command provides an adjustment function equivalent to that of the ADJ command of the MECHATROLINK-II compatible profile.</li> <li>Confirm the completion of the command execution by checking that RCMD = MEM_WR (= 1Eh) and CMD_STAT.CMDRDY = 1, and also checking the setting for ADDRESS, SIZE, MODE/DATA_TYPE and DATA.</li> </ul> <p>In the following cases, an alarm will occur and the command will not be executed.</p> <ul style="list-style-type: none"> <li>When the ADDRESS data is invalid: CMD_ALM = 9h (A.94A)</li> <li>When the MODE/DATA_TYPE data is invalid: CMD_ALM = 9h (A.94B)</li> <li>When the SIZE data is invalid: CMD_ALM = 9h (A.94D)</li> <li>When the DATA data is invalid: CMD_ALM = 9h (A.94B)</li> <li>When the conditions for executing the adjustment operation in the next page are not satisfied: CMD_ALM=Ah (A.95A)</li> <li>While editing using SigmaWin or digital operator: CMD_ALM = Ah (A.95A)</li> </ul> <p>Refer to the following manual for details.</p>  $\Sigma$ -7-Series MECHATROLINK-III Communications Standard Servo Profile Command Manual (Manual No.: SIEP S800001 31)		
1	WDT	RWDT			
2	CMD_CTRL	CMD_STAT			
3					
4	Reserved	Reserved			
5	MODE/DATA_TYPE	MODE/DATA_TYPE			
6	SIZE	SIZE			
7					
8	ADDRESS	ADDRESS			
9					
10					
11					
12	DATA	DATA			
13					
14					
15					
16					
17					
18					
19					
20					
21					
22					
23					
24					
25					
26					
27					
28					
29					
30					
31					



◆ **Command Parameters**

The details of MODE/DATA\_TYPE are described below.

bit7	bit6	bit5	bit4	bit3	bit2	bit1	bit0
MODE				DATA_TYPE			

MODE = 1: Volatile memory, 2: Non-volatile memory (Non-volatile memory can be selected only for common parameters)

DATA\_TYPE = 1: Byte, 2: Short, 3: Long, 4: Not supported

SIZE: Data size for writing (type specified by DATA\_TYPE)

ADDRESS: Initial address for writing

DATA: Data to be written

◆ **Command Warning**

◆ The details of CMD\_ALM of the MEM\_RD/MEM\_WR command are described below.

CMD_ALM	Displayed Code	Error Details
9h	A.94A	When an initial address outside the defined areas is specified
		When an address within the reserved ranges of common parameter or vendor-specific areas is specified
		When a value other than a multiple of the data size specified in DATA_TYPE is set for ADDRESS
	A.94B	When the MODE or DATA_TYPE data is invalid
A.94D	When the initial address is within the defined areas but the specified size goes beyond those areas	
	When a data size beyond the specification of the command format is set for SIZE	

◆ **Setting Command Data**

Examples of using the MEM\_WR command for triggers at preset positions to write the setting table parameters, saving the settings to non-volatile memory, and initializing related parameters are given below.

■ **Example of Setting the Output Position for Output Setting 1 to 100,000**

ADDRESS = 0xF0050000

MODE/DATA\_TYPE = 0x13

SIZE = 0x01

DATA = 100000

■ **Saving Parameters Related to Outputs at Preset Positions**

Use the following procedure to save the settings in RAM to non-volatile memory. Send the commands in the following order.

Step	Description	Setting Example
1	Set the request code for writing to non-volatile memory.	ADDRESS = 0x80004000 MODE/DATA_TYPE = 0x12 SIZE = 0x0001 DATA = 0x2025
2	Execute preparation process 1 for writing to non-volatile memory.	ADDRESS = 0x800041E0 MODE/DATA_TYPE = 0x12 SIZE = 0x0001 DATA = 0x0000
3	Execute preparation process 2 for writing to non-volatile memory.	ADDRESS = 0x800041E4 MODE/DATA_TYPE = 0x13 SIZE = 0x0001 DATA = 0xF0050000

Continued on next page.

Continued from previous page.

Step	Description	Setting Example
4	Execute preparation process 3 for writing to non-volatile memory.	ADDRESS = 0x80004002 MODE/DATA_TYPE = 0x12 SIZE = 0x0001 DATA = 0x0002
5	Execute the write to non-volatile memory.	ADDRESS = 0x80004002 MODE/DATA_TYPE = 0x12 SIZE = 0x0001 DATA = 0x0001
6	End the write to non-volatile memory.	ADDRESS = 0x80004000 MODE/DATA_TYPE = 0x12 SIZE = 0x0001 DATA = 0x0000

This concludes the procedure to save the related parameters.

#### ■ Setting Example to Initialize Related Parameters

Use the following procedure to initialize the settings of the setting table in non-volatile memory to the default values. Refer to the following section for details on the setting table.

 3.2.1 Setting Table Details on page 3-5

Send the commands in the following order.

Step	Description	Setting Example
1	Set the request code for initializing non-volatile memory.	ADDRESS = 0x80004000 MODE/DATA_TYPE = 0x12 SIZE = 0x0001 DATA = 0x2025
2	Execute preparation process 1 for initializing non-volatile memory.	ADDRESS = 0x800041E0 MODE/DATA_TYPE = 0x12 SIZE = 0x0001 DATA = 0x0003
3	Execute preparation process 2 for initializing non-volatile memory.	ADDRESS = 0x800041E4 MODE/DATA_TYPE = 0x13 SIZE = 0x0001 DATA = 0xF0050000
4	Execute preparation process 3 for initializing non-volatile memory.	ADDRESS = 0x80004002 MODE/DATA_TYPE = 0x12 SIZE = 0x0001 DATA = 0x0002
5	Execute the initialization of non-volatile memory.	ADDRESS = 0x80004002 MODE/DATA_TYPE = 0x12 SIZE = 0x0001 DATA = 0x0001
6	End the initialization of non-volatile memory.	ADDRESS = 0x80004000 MODE/DATA_TYPE = 0x12 SIZE = 0x0001 DATA = 0x0000

This concludes the procedure to initialize the related parameters.

## 3.3 Forced Stop Setting for Triggers at Preset Positions

You can force-stop triggers at preset positions by setting bit 30 in the SVCMD\_IO output area to 1. This method can also be used to temporarily stop triggers at preset positions, such as during origin return operations.

Bit 7	Bit 6	Bit 5	Bit 4	Bit 3	Bit 2	Bit 1	Bit 0
N_CL	P_CL	P_PPI	V_PPI	Reserved (0).			
Bit 15	Bit 14	Bit 13	Bit 12	Bit 11	Bit 10	Bit 9	Bit 8
Reserved (0).				G-SEL			
Bit 23	Bit 22	Bit 21	Bit 20	Bit 19	Bit 18	Bit 17	Bit 16
Reserved (0).	SO3	SO2	SO1	BANK_SEL			
Bit 31	Bit 30	Bit 29	Bit 28	Bit 27	Bit 26	Bit 25	Bit 24
Reserved (0).	FOUT_STOP	Reserved (0).	Reserved (0).	Reserved (0).			
Bit	Name	Description	Value	Setting	When Enabled		
30	FOUT_STOP	Request to stop outputting triggers at preset positions	0	None.	Rising edge		
			1	Request stopping outputs at preset positions.			
This bit is used to request that the triggers at preset position outputs be stopped.							

# Rotational Coordinate System

---

# 4

**4.1** Outline ..... 4-2

**4.2** Setup Procedure ..... 4-3

- 4.2.1 Setting the Rotational Coordinate System ..... 4-3
- 4.2.2 Setting the Multiturn Limit ..... 4-4
- 4.2.3 Absolute Encoder Origin Offset ..... 4-4
- 4.2.4 Setting the Moving Method of the Rotational  
Coordinate System ..... 4-5
- 4.2.5 Servo Commands to Use ..... 4-7
- 4.2.6 Monitoring ..... 4-12

# 4.1 Outline

You can set the range of the rotational coordinate system for position data (command position (CPOS) and feedback position (APOS)) from the host controller in SERVOPACK parameters.

The coordinates will be in the range that is set with Pn87C (First Rotational Coordinate) and Pn87A (Last Rotational Coordinate).

The following figure illustrates the operation of the rotational coordinate system.

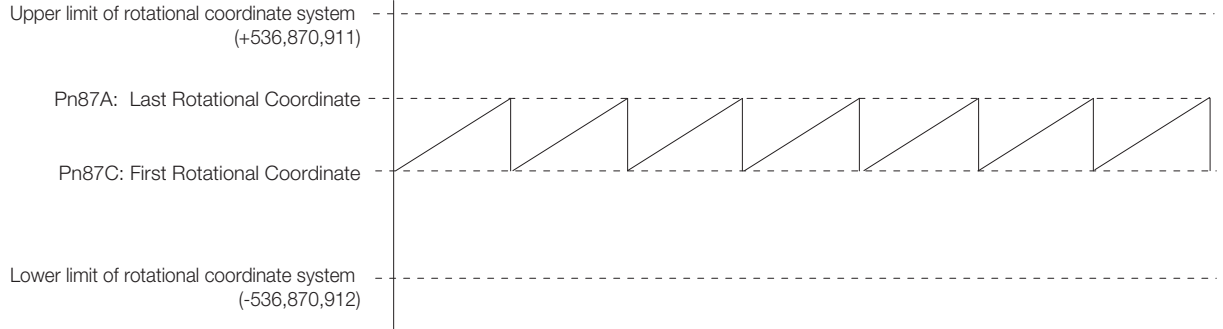

- 

Important

- The rotational coordinate system is enabled by performing one of the following steps.
    - Absolute Encoder  
Send the Turn Sensor ON command (SENS\_ON: 23h) from the host controller.
    - Incremental Encoder
      - Send the Zero Point Return command (ZRET: 3Ah) from the host controller.
      - Use the Set Coordinates command (POS\_SET: 20h) from the host controller to set a reference point (REFE = 1).
  - If the rotational coordinate system is enabled (i.e., Pn87A or Pn87C is not set to 0), software limits and software limit checking are disabled in Pn801 (Application Function Selections 6).

The following figure gives an example of operation when the range of the rotational coordinates for the system is 360° (1 rotation).

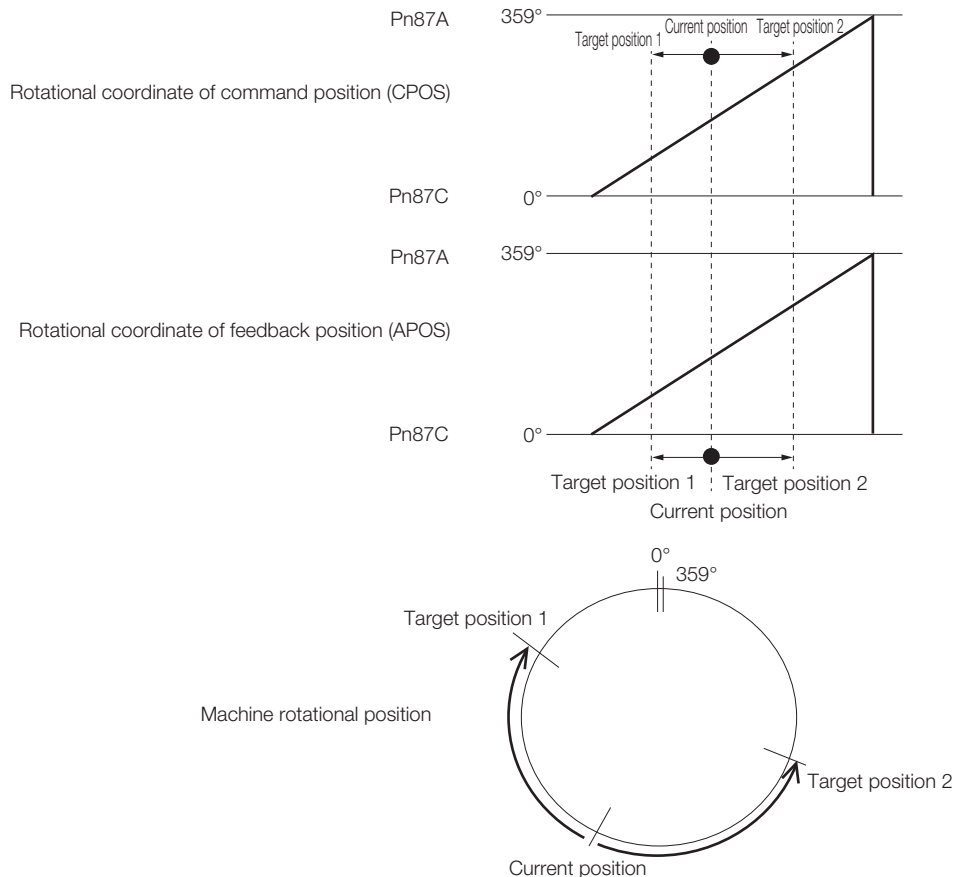

## 4.2 Setup Procedure

The following table gives the procedure for making settings for the rotational coordinate system.

Step	Description
1	Set the first rotational coordinate (Pn87C) and last rotational coordinate (Pn87A).
2	Set the multiturn limit to match the machine rotational coordinate system. (This step is necessary only for an absolute encoder.)
3	Turn the power supply OFF and ON again, or send the Setup Device command (CONFIG: 04h) from the host controller.
4	Set the origin offset for the absolute encoder. (This step is necessary only for an absolute encoder.)
5	Set the movement method for the rotational coordinates (Pn87E = n.□□□X).
6	Perform the following operation for your encoder. Absolute Encoder Send the Turn Sensor ON command (SENS_ON: 23h) from the host controller. Incremental Encoder • Send the Zero Point Return command (ZRET: 3Ah) from the host controller. • Use the Set Coordinates command (POS_SET: 20h) from the host controller to set a reference point (REFE = 1).
7	Start operation.

### 4.2.1 Setting the Rotational Coordinate System

Use the following parameters to set the first rotational coordinate and last rotational coordinate.

Pn87C	First Rotational Coordinate				
	Setting Range	Setting Unit	Default Setting	When Enabled	Classification
	-536,870,912 to 0	1 reference unit	0	After restart	Setup
Pn87A	Last Rotational Coordinate				
	Setting Range	Setting Unit	Default Setting	When Enabled	Classification
	0 to +536,870,911	1 reference unit	0	After restart	Setup

Note: Turn the power supply OFF and ON again, or send the Setup Device command (CONFIG) from the host controller to enable changes to these parameters.



Important

- If Pn87A and Pn87C are set to 0, operation will be performed with linear coordinates (-2,147,483,648 to 2,147,483,647) in the same way as for a standard  $\Sigma$ -7 SERVOPACK.
- In Reverse Rotation Mode (Pn000 = n.□□□1), the motor will operate in the reverse direction, but Pn87A and Pn87C are set to the same direction as the reference direction.

## 4.2.2 Setting the Multiturn Limit

When you use an absolute encoder, set the multiturn limit to match the rotational coordinate system that is used by the system.

When you use a rotational coordinate system, you must set the multiturn limit.

Refer to the following manual for details on setting the multiturn limit.

📖  $\Sigma$ -7-Series  $\Sigma$ -7S SERVOPACK with MECHATROLINK-III Communications References Product Manual (Manual No.: SIEP S800001 28)

Pn205	Multiturn Limit				
	Setting Range	Setting Unit	Default Setting	When Enabled	Classification
	0 to 65,535	1 rev	65535	After restart	Setup
24 (PnA48)	Multiturn Limit Setting				
	Setting Range	Setting Unit	Default Setting	When Enabled	Classification
	0 to 65,535	1 rev	65535	After restart	Setup

Note: Turn the power supply OFF and ON again, or send the Setup Device command (CONFIG) from the host controller to enable changes to these parameters.

**Example** Setting Example for the Multiturn Limit (Pn205)

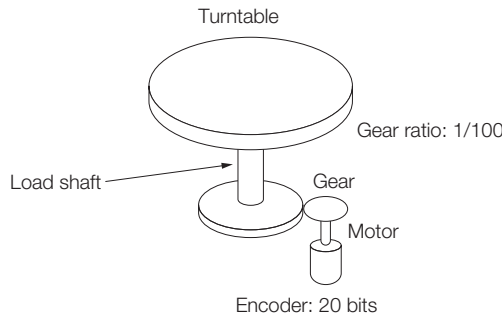

Conditions: A turntable is controlled with rotational coordinates where one revolution equals 360°, which is equal to 36,000 reference units.  
 First rotational coordinate (Pn87C): 0  
 Last rotational coordinate (Pn87A): 35,999  
 Gear ratio: 1/100

The electronic gear ratio is as follows:  $\frac{B}{A} = \frac{Pn20E}{Pn21} = \frac{104,857,600}{36,000}$

With this gear ratio, the motor will turn 100 times for 1 revolution of the turntable. The Multiturn Limit (Pn205) is therefore 99 (100 - 1 = 99).

Important

If the multiturn limit is not set to match the machine rotational coordinate system, the position may become offset.

## 4.2.3 Absolute Encoder Origin Offset

If you use an absolute encoder, you can set Pn808 (Absolute Encoder Origin Offset) to the offset between the encoder position and the machine coordinate system position (feedback position (APOS)).

An example of when the encoder position (X) is at the origin of the machine coordinate system (0) is provided below.

To set encoder position (X) at the origin of the machine coordinate system (0), the following relationship must exist in the parameter settings:  $Pn87C \leq Pn808 \leq Pn87A$ .

Pn808 is set as follows:

- If the offset is smaller than the setting of Pn87C (First Rotational Coordinate):  $Pn808 = \text{Offset} + (Pn87A - Pn87C + 1)$

4.2.4 Setting the Moving Method of the Rotational Coordinate System

- If the offset is greater than the setting of Pn87A (Last Rotational Coordinate):  $Pn808 = \text{Offset} - (Pn87A - Pn87C + 1)$
- If the offset is between Pn87C and Pn87A, inclusive:  $Pn808 = \text{Offset}$

If the settings of the parameters are not in the correct relationship (i.e.,  $Pn87C \leq Pn808 \leq Pn87A$ ), an A.04A alarm (Parameter Setting Error 2) will occur.

Refer to the following section for details on the A.04A alarm.

5.2 List of Alarms on page 5-3

If the encoder position (X) is at the origin of the machine coordinate system (0), then set Pn808 to -X.

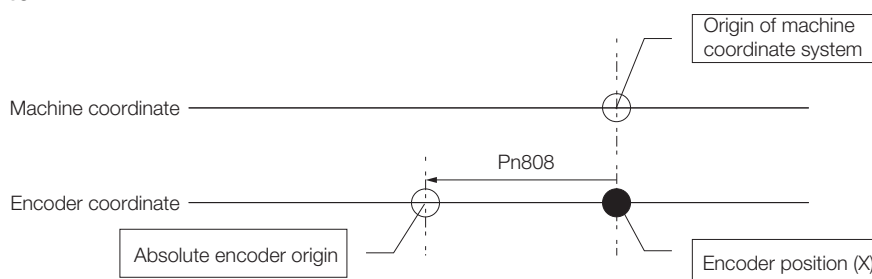

Pn808	Absolute Encoder Origin Offset				
	Setting Range	Setting Unit	Default Setting	When Enabled	Classification
	-1,073,741,823 to 1,073,741,823	1 reference unit	0	Immediately*	Setup
23 (PnA46)	Absolute Encoder Origin Offset				
	Setting Range	Setting Unit	Default Setting	When Enabled	Classification
	-1,073,741,823 to 1,073,741,823	1 reference unit	0	Immediately*	Setup

\* Send the Turn Sensor ON command (SENS\_ON) from the host controller to enable changes to the settings.

## 4.2.4 Setting the Moving Method of the Rotational Coordinate System

Set Pn87E = n.□□□X (Movement Method for Rotational Coordinates) to specify movement in the rotational coordinate system.

**Important** Change the setting of this parameter when there is no reference (i.e., when DEN = 1). If you change it during operation, the new setting is enabled from the next reference operation.

Parameter	Meaning	When Enabled	Classification
Pn87E	n.□□□0	Immediately	Setup
	n.□□□1		
	n.□□□2		
	n.□□□3		

Note: This parameter is enabled when Pn87A or Pn87C is not set to 0.



### Example of Absolute Positioning Operation

Positioning is performed by moving the axis from the current position to the target position. The following figure gives an example of a positioning operation in which the axis is moved forward from the current position to target position 1 and then moved in reverse to target position 2.

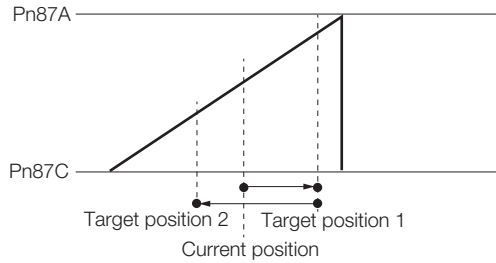

### Example of Reverse Positioning Operation

Positioning is performed by moving the axis in reverse from the current position to the target position. The following figure gives an example of a positioning operation in which the axis is moved in reverse from the current position to target position 1 and then to target position 2.

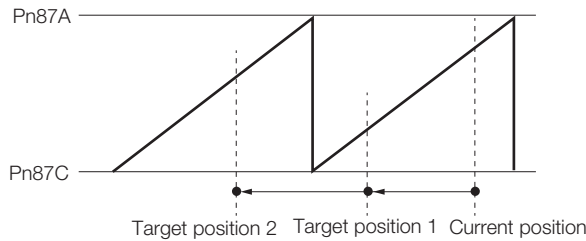

### Example of Forward Positioning Operation

Positioning is performed by moving the axis forward from the current position to the target position. The following figure gives an example of a positioning operation in which the axis is moved forward from the current position to target position 1 and then to target position 2.

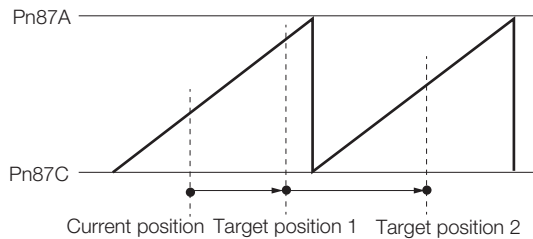

### Example of Near Course Positioning Operation

Positioning is performed by moving the axis in the direction in which the distance from the current position to the target position is shorter.

If the distance from the current position to the target position is the same in both the forward and reverse directions, positioning is performed by moving in the forward direction.

The following figure gives an example of a positioning operation in which the axis is moved in reverse a short distance from the current position to the target position.

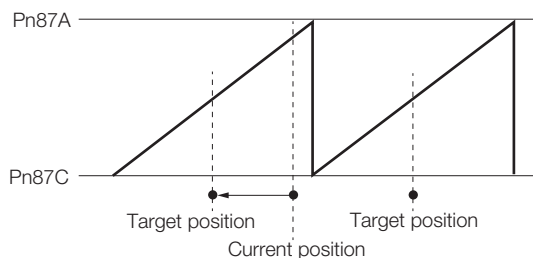

## 4.2.5 Servo Commands to Use

The following table gives the servo command required to use the rotational coordinate system.

Refer to the following manual for details on servo commands.

📖  $\Sigma$ -7-Series MECHATROLINK-III Communications Standard Servo Profile Command Manual (Manual No.: SIEP S800001 31)

Servo Command	Operation	Description
POS_SET (20h)	Set Coordinates command	Set the coordinate within the range of the rotational coordinate system. Set the coordinate setting (POS_DATA) so that $Pn87C \leq POS\_DATA \leq Pn87A$ . If you set a value that exceeds this range, an A.94B alarm (Data Setting Warning 2) will occur and the command will not be executed.
INTERPOLATE (34h)	Interpolation	Interpolation feeding is performed within the range of the rotational coordinate system. Set the target position (TPOS) so that $Pn87C \leq TPOS \leq Pn87A$ . If you set a value that exceeds this range, an A.94B alarm (Data Setting Warning 2) will occur and the command will not be executed. The motor rotation direction is determined by the setting of $Pn87E = n.\square\square\square X$ (Movement Method for Rotational Coordinates).
POSING (35h)	Positioning	Positioning is performed within the range of the rotational coordinate system. Set the target position (TPOS) so that $Pn87C \leq TPOS \leq Pn87A$ . If you set a value that exceeds this range, an A.94B alarm (Data Setting Warning 2) will occur and the command will not be executed. The movement direction is determined by the setting of $Pn87E = n.\square\square\square X$ (Movement Method for Rotational Coordinates).
FEED (36h)	Constant-speed feed	Constant-speed feeding is performed.
EX_FEED (37h)	Positioning at a constant speed for an external input	Positioning within the range of the rotational coordinate system is performed by using an external positioning input signal as a trigger during a constant-speed feeding operation.
EX_POSING (39h)	External input positioning	Positioning within the range of the rotational coordinate system is performed by using an external positioning input signal as a trigger while moving to the target position. Set the target position (TPOS) so that $Pn87C \leq TPOS \leq Pn87A$ . If you set a value that exceeds this range, an A.94B alarm (Data Setting Warning 2) will occur and the command will not be executed. The movement direction is determined by the setting of $Pn87E = n.\square\square\square X$ (Movement Method for Rotational Coordinates).
ZRET (3Ah)	Origin return	An origin return is performed.
VELCTRL (3Ch)	Speed control	Speed control is performed.
TRQCTRL (3Dh)	Torque (force) control	Torque (force) control is performed.

## Movement Direction after Changing to Position Control during Speed Control, Torque Control, or Constant-Speed Control

When you change to position control (POSING or EX\_POSING) during speed control (VELCTRL), torque control (TRQCTRL), or constant-speed control (FEED or EX\_FEED), the movement direction for positioning is determined by the setting of Pn87E = n.□□□X (Movement Method for the Rotational Coordinates).

The following figure gives an example of the operation for changing from speed control to position control.

- Changing to Position Control in the Same Direction (Pn87E = n.□□□0) as the Direction of Speed Control (Direction Specified in the Command)

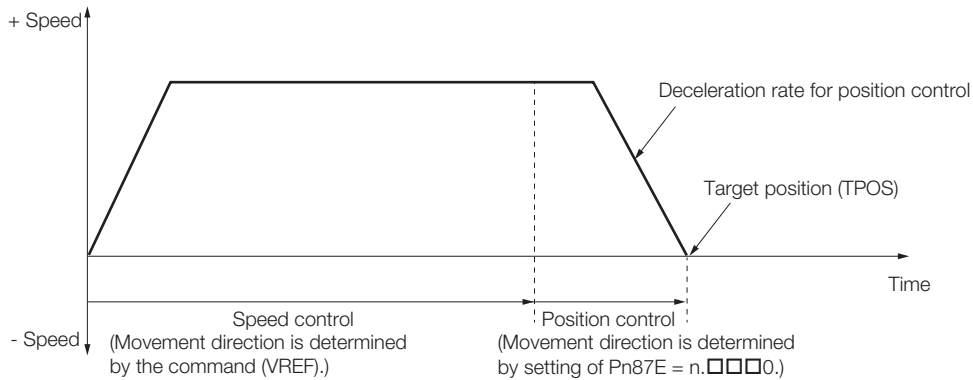

- Changing to Position Control in a Different Direction (Pn87E = n.□□□0) from the Direction of Speed Control (Command Reference Direction)

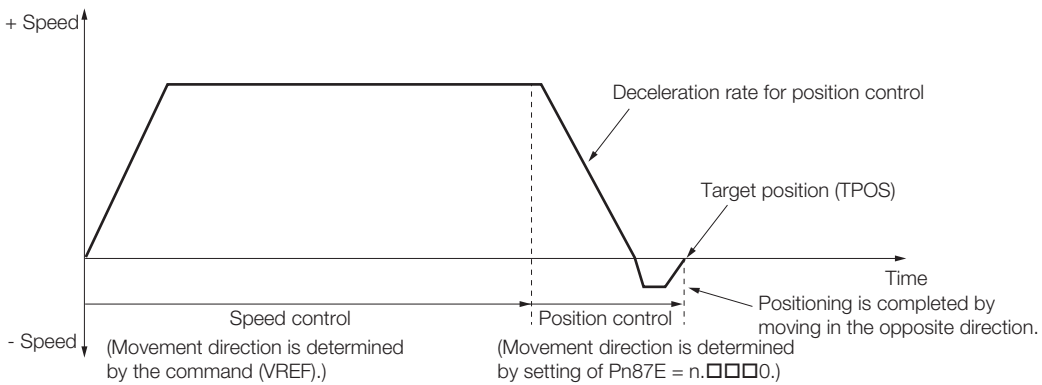

Note: If the Movement Method for Rotational Coordinates (Pn87E = n.□□□X) is set to Absolute Positioning (Pn87E = n.□□□0) or to Positioning by Near Course (Pn87E = n.□□□3), the movement direction will depend on the timing of changing to position control.

## External Input Constant-Speed Feeding and External Input Positioning

If you enable the rotational coordinate system and execute external input constant-speed feeding (EX\_FEED) or external input positioning (EX\_POSING), positioning is performed within the range of the rotational coordinate system to external input positioning position P3 after latching is performed for the external input positioning signal.

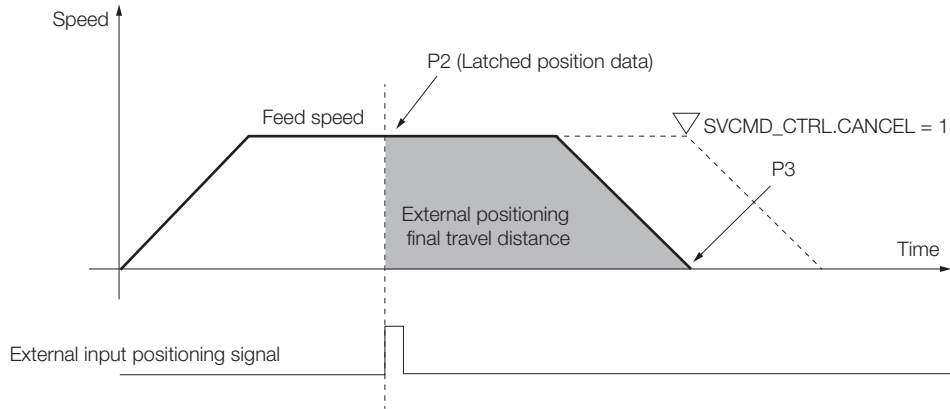

**Example**

**Calculation Example 1 for the External Input Positioning Position P3 in the Rotational Coordinate System**

The following conditions are used in this example.

- First rotational coordinate (Pn87C): 0, Last rotational coordinate (Pn87A): 3,599
- Latched position for external positioning signal, P2: +1,000
- External positioning final travel distance (common parameter 83): +500
- External input positioning position P3:  $1,000 + 500 = 1,500$

Note: The movement direction after latching the position is determined by the sign of the value set for the External Positioning Final Travel Distance (Common Parameter 83).

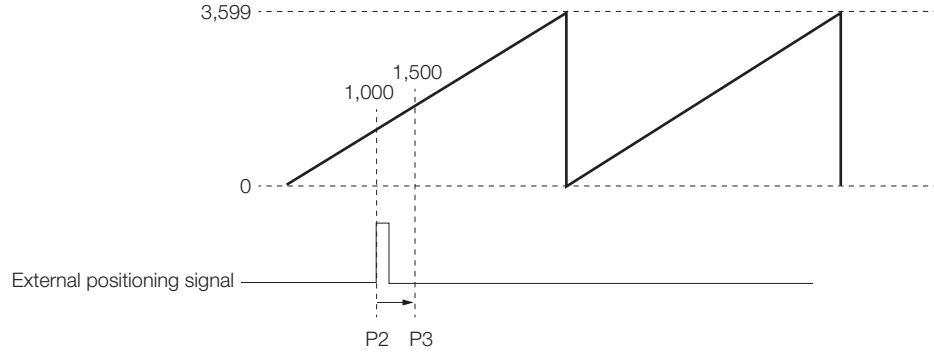

**Calculation Example 2 for the External Input Positioning Position P3 in the Rotational Coordinate System**

The following conditions are used in this example.

- First rotational coordinate (Pn87C): 0, Last rotational coordinate (Pn87A): 3,599
- Latched position for external positioning signal, P2: 1,000
- External positioning final travel distance (common parameter 83): +3,000
- External input positioning position P3:  $1,000 + 3,000 - 3,600$  ( $Pn87A - Pn87C + 1$ ) = 400

Note: The movement direction after latching the position is determined by the sign of the value set for the External Positioning Final Travel Distance (Common Parameter 83).

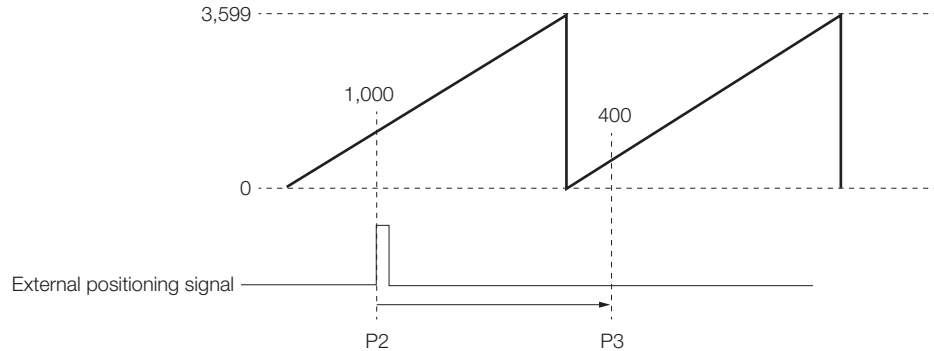

**Calculation Example 3 for the External Input Positioning Position P3 in the Rotational Coordinate System**

The following conditions are used in this example.

- First rotational coordinate (Pn87C): 0, Last rotational coordinate (Pn87A): 3,599
- Latched position for external positioning signal, P2: 1,000
- External positioning final travel distance (common parameter 83): +5,000
- External input positioning position P3:  $1,000 + 5,000 - 3,600$  ( $Pn87A - Pn87C + 1$ ) = 2,400

Note: The movement direction after latching the position is determined by the sign of the value set for the External Positioning Final Travel Distance (Common Parameter 83).

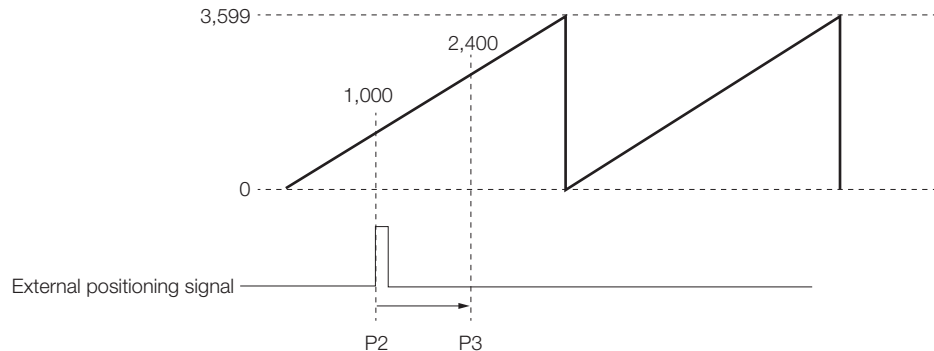

◆ **When External Positioning Final Travel Distance Is Positive**

For forward movement, positioning is performed with forward movement (in the same direction) after latching the position.

For reverse movement, positioning is performed with forward movement (in the opposite direction) after latching the position.

◆ **When External Positioning Final Travel Distance Is Negative**

For forward movement, positioning is performed with reverse movement (in the opposite direction) after latching the position.

For reverse movement, positioning is performed with reverse movement (in the same direction) after latching the position.

## **Positioning for Origin Return Operation**

If you enable the rotational coordinate system and execute an Zero Point Return command (ZRET), positioning is performed within the range of the rotational coordinate system to the origin after latching the position. The final travel distance after latching the position is set in PnBOC (External Positioning Final Travel Distance).

The calculation method to the origin is the same as for external input constant-speed feeding (EX\_FEED) and external input positioning (EX\_POSING).

The movement direction after latching the position is determined by the sign of the value set in PnBOC (External Positioning Final Travel Distance).

◆ **When External Positioning Final Travel Distance Is Positive**

For forward movement, positioning is performed with forward movement (in the same direction) after latching the position.

For reverse movement, positioning is performed with forward movement (in the opposite direction) after latching the position.

◆ **When External Positioning Final Travel Distance Is Negative**

For forward movement, positioning is performed with reverse movement (in the opposite direction) after latching the position.

For reverse movement, positioning is performed with reverse movement (in the same direction) after latching the position.

## 4.2.6 Monitoring

### Monitoring with Servo Commands

The monitor data, which is output within the range of the rotational coordinate system (Pn87A to Pn87C), are listed below.

Refer to the following manual for servo command details.

📖 Σ-7-Series MECHATROLINK-III Communications Standard Servo Profile Command Manual (Manual No.: SIEP S800001 31)

Monitor Name	Monitor Data		Description	Unit
	Specification Method	Setting		
APOS	SEL_MON1 to SEL_MON6	Selected code = 0	Feedback position	1 reference unit
	Fixed Monitor 1 (PnB0E)	0000h		
	Fixed Monitor 2 (PnB10)	0000h		
CPOS	SEL_MON1 to SEL_MON6	Selected code = 1	Command position after reference filter	1 reference unit
	Fixed Monitor 1 (PnB0E)	0001h		
	Fixed Monitor 2 (PnB10)	0001h		
LPOS1	SEL_MON1 to SEL_MON6	Selected code = 3	Latched position 1	1 reference unit
	Fixed Monitor 1 (PnB0E)	0003h		
	Fixed Monitor 2 (PnB10)	0003h		
LPOS2	SEL_MON1 to SEL_MON6	Selected code = 4	Latched position 2	1 reference unit
	Fixed Monitor 1 (PnB0E)	0004h		
	Fixed Monitor 2 (PnB10)	0004h		
MPOS	SEL_MON1 to SEL_MON6	Selected code = 9	Command position (Input reference position for the position loop MPOS = APOS + position deviation)	1 reference unit
	Fixed Monitor 1 (PnB0E)	0009h		
	Fixed Monitor 2 (PnB10)	0009h		
TPOS	Common Monitor 1 (PnB12)	0000h	Target position in the reference coordinate system	1 reference unit
	Common Monitor 2 (PnB14)	0000h		
IPOS	Common Monitor 1 (PnB12)	0001h	Command position before reference filter	1 reference unit
	Common Monitor 2 (PnB14)	0001h		
POS_OFFSET	Common Monitor 1 (PnB12)	0002h	Offset value set with the POS_SET command	1 reference unit
	Common Monitor 2 (PnB14)	0002h		
Previous value of LPOS1	Option Monitor 1 (Pn824)	0080h	Previous value of latched position 1	1 reference unit
	Optional Monitor 2 (Pn825)	0080h		
Previous value of LPOS2	Option Monitor 1 (Pn824)	0081h	Previous value of latched position 2	1 reference unit
	Optional Monitor 2 (Pn825)	0081h		

## Monitoring with the Digital Operator

Display the monitor data in Monitor Mode to monitor values on the Digital Operator.

The monitor data, which is output within the range of the rotational coordinate system (Pn87A to Pn87C), are listed below.

Un No.	Sign	Unit	Name	Description
Un045	Yes	1 reference unit	CPOS	Reference position
Un046	Yes	1 reference unit	APOS	Feedback position

Refer to the following manual for information on monitor data that is not listed above.

 [Σ-7-Series Digital Operator Operating Manual \(Manual No.: SIEP S800001 33\)](#)



# Maintenance

---

# 5

This chapter provides information on the meaning of, causes of, and corrections for alarms and warnings.

<b>5.1</b>	<b>Alarm Displays</b> .....	<b>5-2</b>
<b>5.2</b>	<b>List of Alarms</b> .....	<b>5-3</b>
<b>5.3</b>	<b>Troubleshooting Alarms</b> .....	<b>5-8</b>
<b>5.4</b>	<b>Warning Displays</b> .....	<b>5-33</b>
<b>5.5</b>	<b>List of Warnings</b> .....	<b>5-34</b>
<b>5.6</b>	<b>Troubleshooting Warnings</b> .....	<b>5-36</b>
<b>5.7</b>	<b>Troubleshooting Based on the Operation and Conditions of the Servomotor</b> ..	<b>5-43</b>

## 5.1 Alarm Displays

If an error occurs in the SERVOPACK, an alarm number will be displayed on the panel display. However, if no alarm number appears on the panel display, this indicates a SERVOPACK system error. Replace the SERVOPACK.

If there is an alarm, the display will change in the following order.

Example: Alarm A.E60

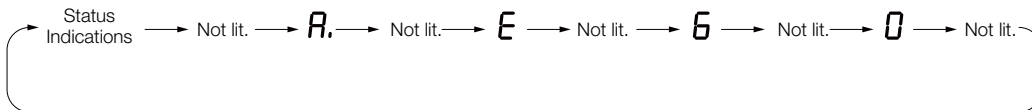

## 5.2 List of Alarms

The list of alarms gives the alarm name, alarm meaning, alarm stopping method, and alarm reset possibility in order of the alarm numbers.

### Servomotor Stopping Method for Alarms

Refer to the following manual for information on the stopping method for alarms.

📖  $\Sigma$ -7-Series  $\Sigma$ -7S SERVOPACK with MECHATROLINK-III Communications References Product Manual (Manual No.: SIEP S800001 28)

📖  $\Sigma$ -7-Series  $\Sigma$ -7S SERVOPACK with MECHATROLINK-III Communications References and RJ-45 Connectors Product Manual (Manual No.: SIEP S800001 62)

### Alarm Reset Possibility

Yes: You can use an alarm reset to clear the alarm. However, this assumes that the cause of the alarm has been removed.

No: You cannot clear the alarm.

### List of Alarms

Alarm Number	Alarm Name	Alarm Meaning	Servo-motor Stopping Method	Alarm Reset Possible?
A.020	Parameter Checksum Error	There is an error in the parameter data in the SERVOPACK.	Gr.1	No
A.021	Parameter Format Error	There is an error in the parameter data format in the SERVOPACK.	Gr.1	No
A.022	System Checksum Error	There is an error in the parameter data in the SERVOPACK.	Gr.1	No
A.024	System Alarm	An internal program error occurred in the SERVOPACK.	Gr.1	No
A.025	System Alarm	An internal program error occurred in the SERVOPACK.	Gr.1	No
A.030	Main Circuit Detector Error	There is an error in the detection data for the main circuit.	Gr.1	Yes
A.040	Parameter Setting Error	A parameter setting is outside of the setting range.	Gr.1	No
A.041	Encoder Output Pulse Setting Error	The setting of Pn212 (Encoder Output Pulses) or Pn281 (Encoder Output Resolution) is outside of the setting range or does not satisfy the setting conditions.	Gr.1	No
A.042	Parameter Combination Error	The combination of some parameters exceeds the setting range.	Gr.1	No
A.044	Semi-Closed/Fully-Closed Loop Control Parameter Setting Error	The settings of the Option Module and Pn002 = n.X□□□ (External Encoder Usage) do not match.	Gr.1	No
A.04A	Parameter Setting Error 2	There is an error in the bank members or bank data settings.	Gr.1	No
A.050	Combination Error	The capacities of the SERVOPACK and Servomotor do not match.	Gr.1	Yes
A.051	Unsupported Device Alarm	An unsupported device was connected.	Gr.1	No
A.0b0	Invalid Servo ON Command Alarm	The SV_ON (Servo ON) command was sent from the host controller after a utility function that turns ON the Servomotor was executed.	Gr.1	Yes

Continued on next page.

Continued from previous page.

Alarm Number	Alarm Name	Alarm Meaning	Servo-motor Stopping Method	Alarm Reset Possible?
A.100	Overcurrent Detected	An overcurrent flowed through the power transformer or the heat sink overheated.	Gr.1	No
A.101	Motor Overcurrent Detected	The current to the motor exceeded the allowable current.	Gr.1	No
A.300	Regeneration Error	There is an error related to regeneration.	Gr.1	Yes
A.320	Regenerative Overload	A regenerative overload occurred.	Gr.2	Yes
A.330	Main Circuit Power Supply Wiring Error	<ul style="list-style-type: none"> <li>The AC power supply input setting or DC power supply input setting is not correct.</li> <li>The power supply wiring is not correct.</li> </ul>	Gr.1	Yes
A.400	Overvoltage	The main circuit DC voltage is too high.	Gr.1	Yes
A.410	Undervoltage	The main circuit DC voltage is too low.	Gr.2	Yes
A.510	Overspeed	The motor exceeded the maximum speed.	Gr.1	Yes
A.511	Encoder Output Pulse Overspeed	The pulse output speed for the setting of Pn212 (Encoder Output Pulses) was exceeded.	Gr.1	Yes
A.520	Vibration Alarm	Abnormal oscillation was detected in the motor speed.	Gr.1	Yes
A.521	Autotuning Alarm	Vibration was detected during autotuning for the tuning-less function.	Gr.1	Yes
A.550	Maximum Speed Setting Error	The setting of Pn385 (Maximum Motor Speed) is greater than the maximum motor speed.	Gr.1	Yes
A.710	Instantaneous Overload	The Servomotor was operating for several seconds to several tens of seconds under a torque that largely exceeded the rating.	Gr.2	Yes
A.720	Continuous Overload	The Servomotor was operating continuously under a torque that exceeded the rating.	Gr.1	Yes
A.730	Dynamic Brake Overload	When the dynamic brake was applied, the rotational or linear kinetic energy exceeded the capacity of the dynamic brake resistor.	Gr.1	Yes
A.731				
A.740	Inrush Current Limiting Resistor Overload	The main circuit power supply was frequently turned ON and OFF.	Gr.1	Yes
A.7A1	Internal Temperature Error 1 (Control Board Temperature Error)	The surrounding temperature of the control PCB is abnormal.	Gr.2	Yes
A.7A2	Internal Temperature Error 2 (Power Board Temperature Error)	The surrounding temperature of the power PCB is abnormal.	Gr.2	Yes
A.7A3	Internal Temperature Sensor Error	An error occurred in the temperature sensor circuit.	Gr.2	No
A.7Ab	SERVOPACK Built-in Fan Stopped	The fan inside the SERVOPACK stopped.	Gr.1	Yes
A.810	Encoder Backup Alarm	The power supplies to the encoder all failed and the position data was lost.	Gr.1	No
A.820	Encoder Checksum Alarm	There is an error in the checksum results for encoder memory.	Gr.1	No
A.830	Encoder Battery Alarm	The battery voltage was lower than the specified level after the control power supply was turned ON.	Gr.1	Yes
A.840	Encoder Data Alarm	There is an internal data error in the encoder.	Gr.1	No
A.850	Encoder Overspeed	The encoder was operating at high speed when the power was turned ON.	Gr.1	No
A.860	Encoder Overheated	The internal temperature of encoder is too high.	Gr.1	No
A.861	Motor Overheated	The internal temperature of motor is too high.	Gr.1	No

Continued on next page.

Continued from previous page.

Alarm Number	Alarm Name	Alarm Meaning	Servo-motor Stopping Method	Alarm Reset Possible?
A.862	Overheat Alarm	The input voltage (temperature) for the overheat protection input (TH) signal exceeded the setting of Pn61B (Overheat Alarm Level).	Gr.1	Yes
A.8A0	External Encoder Error	An error occurred in the external encoder.	Gr.1	Yes
A.8A1	External Encoder Module Error	An error occurred in the Serial Converter Unit.	Gr.1	Yes
A.8A2	External Incremental Encoder Sensor Error	An error occurred in the external encoder.	Gr.1	Yes
A.8A3	External Absolute Encoder Position Error	An error occurred in the position data of the external encoder.	Gr.1	Yes
A.8A5	External Encoder Over-speed	An overspeed error occurred in the external encoder.	Gr.1	Yes
A.8A6	External Encoder Over-heated	An overheating error occurred in the external encoder.	Gr.1	Yes
A.b33	Current Detection Error 3	An error occurred in the current detection circuit.	Gr.1	No
A.b6A	MECHATROLINK Communications ASIC Error 1	ASIC error 1 occurred in MECHATROLINK communications.	Gr.1	No
A.b6b	MECHATROLINK Communications ASIC Error 2	ASIC error 2 occurred in MECHATROLINK communications.	Gr.2	No
A.bF0	System Alarm 0	Internal program error 0 occurred in the SERVO-PACK.	Gr.1	No
A.bF1	System Alarm 1	Internal program error 1 occurred in the SERVO-PACK.	Gr.1	No
A.bF2	System Alarm 2	Internal program error 2 occurred in the SERVO-PACK.	Gr.1	No
A.bF3	System Alarm 3	Internal program error 3 occurred in the SERVO-PACK.	Gr.1	No
A.bF4	System Alarm 4	Internal program error 4 occurred in the SERVO-PACK.	Gr.1	No
A.bF5	System Alarm 5	Internal program error 5 occurred in the SERVO-PACK.	Gr.1	No
A.bF6	System Alarm 6	Internal program error 6 occurred in the SERVO-PACK.	Gr.1	No
A.bF7	System Alarm 7	Internal program error 7 occurred in the SERVO-PACK.	Gr.1	No
A.bF8	System Alarm 8	Internal program error 8 occurred in the SERVO-PACK.	Gr.1	No
A.C10	Servomotor Out of Control	The Servomotor ran out of control.	Gr.1	Yes
A.C80	Encoder Clear Error or Multiturn Limit Setting Error	The multiturn data for the absolute encoder was not correctly cleared or set.	Gr.1	No
A.C90	Encoder Communications Error	Communications between the encoder and SERVO-PACK is not possible.	Gr.1	No
A.C91	Encoder Communications Position Data Acceleration Rate Error	An error occurred in calculating the position data of the encoder.	Gr.1	No
A.C92	Encoder Communications Timer Error	An error occurred in the communications timer between the encoder and SERVO-PACK.	Gr.1	No
A.CA0	Encoder Parameter Error	The parameters in the encoder are corrupted.	Gr.1	No
A.Cb0	Encoder Echoback Error	The contents of communications with the encoder are incorrect.	Gr.1	No

Continued on next page.

Continued from previous page.

Alarm Number	Alarm Name	Alarm Meaning	Servo-motor Stopping Method	Alarm Reset Possible?
A.CC0	Multiturn Limit Disagreement	Different multiturn limits have been set in the encoder and the SERVOPACK.	Gr.1	No
A.CF1	Reception Failed Error in Feedback Option Module Communications	Receiving data from the Feedback Option Module failed.	Gr.1	No
A.CF2	Timer Stopped Error in Feedback Option Module Communications	An error occurred in the timer for communications with the Feedback Option Module.	Gr.1	No
A.d00	Position Deviation Overflow	The setting of Pn520 (Excessive Position Deviation Alarm Level) was exceeded by the position deviation while the servo was ON.	Gr.1	Yes
A.d01	Position Deviation Overflow Alarm at Servo ON	The servo was turned ON after the position deviation exceeded the setting of Pn526 (Excessive Position Deviation Alarm Level at Servo ON) while the servo was OFF.	Gr.1	Yes
A.d02	Position Deviation Overflow Alarm for Speed Limit at Servo ON	If position deviation remains in the deviation counter, the setting of Pn529 or Pn584 (Speed Limit Level at Servo ON) limits the speed when the servo is turned ON. This alarm occurs if a position reference is input and the setting of Pn520 (Excessive Position Deviation Alarm Level) is exceeded before the limit is cleared.	Gr.2	Yes
A.d10	Motor-Load Position Deviation Overflow	There was too much position deviation between the motor and load during fully-closed loop control.	Gr.2	Yes
A.d30	Position Data Overflow	The position feedback data exceeded $\pm 1,879,048,192$ .	Gr.1	No
A.E02	MECHATROLINK Internal Synchronization Error 1	A synchronization error occurred during MECHATROLINK communications with the SERVOPACK.	Gr.1	Yes
A.E40	MECHATROLINK Transmission Cycle Setting Error	The setting of the MECHATROLINK communications transmission cycle is not correct.	Gr.2	Yes
A.E41	MECHATROLINK Communications Data Size Setting Error	The setting of the MECHATROLINK communications data size is not correct.	Gr.2	Yes
A.E42	MECHATROLINK Station Address Setting Error	The setting of the MECHATROLINK station address is not correct.	Gr.2	No
A.E50*	MECHATROLINK Synchronization Error	A synchronization error occurred during MECHATROLINK communications.	Gr.2	Yes
A.E51	MECHATROLINK Synchronization Failed	Synchronization failed during MECHATROLINK communications.	Gr.2	Yes
A.E60*	Reception Error in MECHATROLINK Communications	Communications errors occurred continuously during MECHATROLINK communications.	Gr.2	Yes
A.E61	Synchronization Interval Error in MECHATROLINK Transmission Cycle	An error occurred in the transmission cycle during MECHATROLINK communications.	Gr.2	Yes
A.E63	MECHATROLINK Synchronization Frame Not Received	Synchronization frames were continuously not received during MECHATROLINK communications.	Gr.2	Yes
A.E71	Safety Option Module Detection Failure	Detection of the Safety Option Module failed.	Gr.1	No

Continued on next page.

Continued from previous page.

Alarm Number	Alarm Name	Alarm Meaning	Servo-motor Stopping Method	Alarm Reset Possible?
A.E72	Feedback Option Module Detection Failure	Detection of the Feedback Option Module failed.	Gr.1	No
A.E74	Unsupported Safety Option Module	An unsupported Safety Option Module was connected.	Gr.1	No
A.Eb1	Safety Function Signal Input Timing Error	An error occurred in the input timing of the safety function signal.	Gr.1	No
A.EC8	Gate Drive Error 1	An error occurred in the gate drive circuit.	Gr.1	No
A.EC9	Gate Drive Error 2	An error occurred in the gate drive circuit.	Gr.1	No
A.Ed1	Command Execution Timeout	A timeout error occurred for a MECHATROLINK command.	Gr.2	Yes
A.F10	Power Supply Line Open Phase	The voltage was low for more than one second for phase R, S, or T when the main power supply was ON.	Gr.2	Yes
FL-1*	System Alarm	An internal program error occurred in the SERVOPACK.	-	No
FL-2*				
FL-3*				
FL-4*				
FL-5*				
FL-6*				
CPF00	Digital Operator Communications Error 1	Communications were not possible between the Digital Operator (model: JUSP-OP05A-1-E) and the SERVOPACK (e.g., a CPU error occurred).	-	No
CPF01	Digital Operator Communications Error 2			

\* These alarms are not stored in the alarm history. They are only displayed on the panel display.

Note: The A.Eb0, A.Eb2 to A.Eb9, and A.EC0 to A.EC2 alarms can occur when a Safety Module is connected. Refer to the following manual for details.

 AC Servo Drive  $\Sigma$ -V-Series/ $\Sigma$ -V-Series for Large-Capacity Models/ $\Sigma$ -7-Series User's Manual Safety Module (Manual No.: SIEP C720829 06)

## 5.3 Troubleshooting Alarms

The causes of and corrections for the alarms are given in the following table. Contact your Yaskawa representative if you cannot solve a problem with the correction given in the table.

Alarm Number: Alarm Name	Possible Cause	Confirmation	Correction	Reference
A.020: Parameter Checksum Error (There is an error in the parameter data in the SER- VOPACK.)	The power supply voltage suddenly dropped.	Measure the power supply voltage.	Set the power supply voltage within the specified range, and initialize the parameter settings.	*1
	The power supply was shut OFF while writing parameter settings.	Check the timing of shutting OFF the power supply.	Initialize the parameter settings and then set the parameters again.	
	The number of times that parameters were written exceeded the limit.	Check to see if the parameters were frequently changed from the host controller.	The SERVOPACK may be faulty. Replace the SERVOPACK. Reconsider the method for writing the parameters.	-
	A malfunction was caused by noise from the AC power supply, ground, static electricity, or other source.	Turn the power supply to the SERVOPACK OFF and ON again. If the alarm still occurs, noise may be the cause.	Implement countermeasures against noise.	*1
	Gas, water drops, or cutting oil entered the SERVOPACK and caused failure of the internal components.	Check the installation conditions.	The SERVOPACK may be faulty. Replace the SERVOPACK.	-
	A failure occurred in the SERVOPACK.	Turn the power supply to the SERVOPACK OFF and ON again. If the alarm still occurs, the SERVOPACK may have failed.	The SERVOPACK may be faulty. Replace the SERVOPACK.	-
A.021: Parameter Format Error (There is an error in the parameter data format in the SERVOPACK.)	The software version of the SERVOPACK that caused the alarm is older than the software version of the parameters specified to write.	Read the product information to see if the software versions are the same. If they are different, it could be the cause of the alarm.	Write the parameters from another SERVOPACK with the same model and the same software version, and then turn the power OFF and ON again.	*1
	A failure occurred in the SERVOPACK.	-	The SERVOPACK may be faulty. Replace the SERVOPACK.	-
A.022: System Checksum Error (There is an error in the parameter data in the SERVOPACK.)	The power supply voltage suddenly dropped.	Measure the power supply voltage.	The SERVOPACK may be faulty. Replace the SERVOPACK.	-
	The power supply was shut OFF while setting a utility function.	Check the timing of shutting OFF the power supply.	The SERVOPACK may be faulty. Replace the SERVOPACK.	-
	A failure occurred in the SERVOPACK.	Turn the power supply to the SERVOPACK OFF and ON again. If the alarm still occurs, the SERVOPACK may have failed.	The SERVOPACK may be faulty. Replace the SERVOPACK.	-

Continued on next page.



Continued from previous page.

Alarm Number: Alarm Name	Possible Cause	Confirmation	Correction	Reference
<b>A.024:</b> System Alarm (An internal program error occurred in the SERVOPACK.)	A failure occurred in the SERVOPACK.	–	The SERVOPACK may be faulty. Replace the SERVOPACK.	–
<b>A.025:</b> System Alarm (An internal program error occurred in the SERVOPACK.)	A failure occurred in the SERVOPACK.	–	The SERVOPACK may be faulty. Replace the SERVOPACK.	–
<b>A.030:</b> Main Circuit Detector Error	A failure occurred in the SERVOPACK.	–	The SERVOPACK may be faulty. Replace the SERVOPACK.	–
<b>A.040:</b> Parameter Setting Error (A parameter setting is outside of the setting range.)	The SERVOPACK and Servomotor capacities do not match each other.	Check the combination of the SERVOPACK and Servomotor capacities.	Select a proper combination of SERVOPACK and Servomotor capacities.	*1
	A failure occurred in the SERVOPACK.	–	The SERVOPACK may be faulty. Replace the SERVOPACK.	–
	A parameter setting is outside of the setting range.	Check the setting ranges of the parameters that have been changed.	Set the parameters to values within the setting ranges.	–
	The electronic gear ratio is outside of the setting range.	Check the electronic gear ratio. The ratio must be within the following range: $0.001 < (Pn20E/Pn210) < 64,000$ .	Set the electronic gear ratio in the following range: $0.001 < (Pn20E/Pn210) < 64,000$ .	*1
<b>A.041:</b> Encoder Output Pulse Setting Error	The setting of Pn212 (Encoder Output Pulses) or Pn281 (Encoder Output Resolution) is outside of the setting range or does not satisfy the setting conditions.	Check the setting of Pn212 or Pn281.	Set Pn212 or Pn281 to an appropriate value.	*1
<b>A.042:</b> Parameter Combination Error	The speed of program jogging went below the setting range when the electronic gear ratio (Pn20E/Pn210) or the Servomotor was changed.	Check to see if the detection conditions*2 are satisfied.	Decrease the setting of the electronic gear ratio (Pn20E/Pn210).	*1
	The speed of program jogging went below the setting range when Pn533 or Pn585 (Program Jogging Speed) was changed.	Check to see if the detection conditions*2 are satisfied.	Increase the setting of Pn533 or Pn585.	*1
	The movement speed of advanced autotuning went below the setting range when the electronic gear ratio (Pn20E/Pn210) or the Servomotor was changed.	Check to see if the detection conditions*3 are satisfied.	Decrease the setting of the electronic gear ratio (Pn20E/Pn210).	*1

Continued on next page.

Continued from previous page.

Alarm Number: Alarm Name	Possible Cause	Confirmation	Correction	Reference
A.044: Semi-Closed/ Fully-Closed Loop Control Parameter Setting Error	The setting of the Fully-Closed Module does not match the setting of Pn002 = n.X□□□ (External Encoder Usage).	Check the setting of Pn002 = n.X□□□.	Make sure that the setting of the Fully-closed Module agrees with the setting of Pn002 = n.X□□□.	*1
A.04A: Parameter Setting Error 2	For 4-byte parameter bank members, there are two consecutive members with nothing registered.	–	Change the number of bytes for bank members to an appropriate value.	–
	The total amount of bank data exceeds 64 (Pn900 × Pn901 > 64).	–	Reduce the total amount of bank data to 64 or less.	–
A.050: Combination Error (The capacities of the SERVOPACK and Servomotor do not match.)	The SERVOPACK and Servomotor capacities do not match each other.	Confirm that the following condition is met: $1/4 \leq (\text{Servomotor capacity}/\text{SERVOPACK capacity}) \leq 4$	Select a proper combination of the SERVOPACK and Servomotor capacities.	*1
	A failure occurred in the encoder.	Replace the encoder and check to see if the alarm still occurs.	Replace the Servomotor or encoder.	–
	A failure occurred in the SERVOPACK.	–	The SERVOPACK may be faulty. Replace the SERVOPACK.	–
A.051: Unsupported Device Alarm	An unsupported Serial Converter Unit or encoder (e.g., an external encoder) is connected to the SERVOPACK.	Check the product combination specifications.	Change to a correct combination of models.	–
A.0b0: Invalid Servo ON Command Alarm	The SV_ON (Servo ON) command was sent from the host controller after a utility function that turns ON the Servomotor was executed.	–	Turn the power supply to the SERVOPACK OFF and ON again. Or, execute a software reset.	*1

Continued on next page.

Continued from previous page.

Alarm Number: Alarm Name	Possible Cause	Confirmation	Correction	Reference
A.100: Overcurrent Detected (An overcurrent flowed through the power trans- former or the heat sink overheated.)	The Main Circuit Cable is not wired correctly or there is faulty contact.	Check the wiring.	Correct the wiring.	
	There is a short-circuit or ground fault in a Main Circuit Cable.	Check for short-circuits across Servomotor phases U, V, and W, or between the ground and Servomotor phases U, V, and W.	The cable may be short-circuited. Replace the cable.	
	There is a short-circuit or ground fault inside the Servomotor.	Check for short-circuits across Servomotor phases U, V, and W, or between the ground and Servomotor phases U, V, or W.	The Servomotor may be faulty. Replace the Servomotor.	*1
	There is a short-circuit or ground fault inside the SERVOPACK.	Check for short-circuits across the Servomotor connection terminals U, V, and W on the SERVOPACK, or between the ground and terminals U, V, or W.	The SERVOPACK may be faulty. Replace the SERVOPACK.	
	The regenerative resistor is not wired correctly or there is faulty contact.	Check the wiring.	Correct the wiring.	*1
	The dynamic brake (DB, emergency stop executed from the SERVOPACK) was frequently activated, or a DB overload alarm occurred.	Check the power consumed by the DB resistor to see how frequently the DB is being used. Or, check the alarm display to see if a DB overload alarm (A.730 or A.731) has occurred.	Change the SERVOPACK model, operating methods, or the mechanisms so that the dynamic brake does not need to be used so frequently.	-
	The regenerative processing capacity was exceeded.	Check the regenerative load ratio in the SigmaWin+ Motion Monitor Tab Page to see how frequently the regenerative resistor is being used.	Recheck the operating conditions and load.	*4
	The SERVOPACK regenerative resistance is too small.	Check the regenerative load ratio in the SigmaWin+ Motion Monitor Tab Page to see how frequently the regenerative resistor is being used.	Change the regenerative resistance to a value larger than the SERVOPACK minimum allowable resistance.	

Continued on next page.

Continued from previous page.

Alarm Number: Alarm Name	Possible Cause	Confirmation	Correction	Reference
A.100: Overcurrent Detected (An overcurrent flowed through the power trans- former or the heat sink overheated.)	A heavy load was applied while the Servomotor was stopped or running at a low speed.	Check to see if the operating conditions exceed Servo Drive specifications.	Reduce the load applied to the Servomotor. Or, increase the operating speed.	-
	A malfunction was caused by noise.	Improve the noise environment, e.g. by improving the wiring or installation conditions, and check to see if the alarm still occurs.	Implement countermeasures against noise, such as correct wiring of the FG. Use an FG wire size equivalent to the SERVOPACK's main circuit wire size.	-
	A failure occurred in the SERVOPACK.	-	Turn the power supply to the SERVOPACK OFF and ON again. If an alarm still occurs, the SERVOPACK may be faulty. Replace the SERVOPACK.	-
A.101: Motor Overcurrent Detected (The current to the motor exceeded the allowable current.)	The Main Circuit Cable is not wired correctly or there is faulty contact.	Check the wiring.	Correct the wiring.	
	There is a short-circuit or ground fault in a Main Circuit Cable.	Check for short-circuits across cable phases U, V, and W, or between the ground and cable phases U, V, and W.	The cable may be short-circuited. Replace the cable.	
	There is a short-circuit or ground fault inside the Servomotor.	Check for short-circuits across Servomotor phases U, V, and W, or between the ground and Servomotor phases U, V, or W.	The Servomotor may be faulty. Replace the Servomotor.	*1
	There is a short-circuit or ground fault inside the SERVOPACK.	Check for short-circuits across the Servomotor connection terminals U, V, and W on the SERVOPACK, or between the ground and terminals U, V, or W.	The SERVOPACK may be faulty. Replace the SERVOPACK.	
	A heavy load was applied while the Servomotor was stopped or running at a low speed.	Check to see if the operating conditions exceed Servo Drive specifications.	Reduce the load applied to the Servomotor. Or, increase the operating speed.	-
	A malfunction was caused by noise.	Improve the noise environment, e.g. by improving the wiring or installation conditions, and check to see if the alarm still occurs.	Implement countermeasures against noise, such as correct wiring of the FG. Use an FG wire size equivalent to the SERVOPACK's main circuit wire size.	-
	A failure occurred in the SERVOPACK.	-	Turn the power supply to the SERVOPACK OFF and ON again. If an alarm still occurs, the SERVOPACK may be faulty. Replace the SERVOPACK.	-

Continued on next page.

Continued from previous page.

Alarm Number: Alarm Name	Possible Cause	Confirmation	Correction	Reference
A.300: Regeneration Error	Pn600 (Regenerative Resistor Capacity) is not set to 0 and an External Regenerative Resistor is not connected to one of the following SERVO-PACKs: SGD7S-2R8A or -2R8F.	Check to see if an External Regenerative Resistor is connected and check the setting of Pn600.	Connect an External Regenerative Resistor, or set Pn600 (Regenerative Resistor Capacity) to 0 (setting unit: $\times 10$ W) if no Regenerative Resistor is required.	*1
	The jumper between the regenerative resistor terminals (B2 and B3) was removed from one of the following SERVO-PACKs: SGD7S-120A.	Check to see if the jumper is connected between power supply terminals B2 and B3.	Correctly connect a jumper.	*1
	The External Regenerative Resistor is not wired correctly, or was removed or disconnected.	Check the wiring of the External Regenerative Resistor.	Correct the wiring of the External Regenerative Resistor.	
	A failure occurred in the SERVOPACK.	–	While the main circuit power supply is OFF, turn the control power supply to the SERVOPACK OFF and ON again. If an alarm still occurs, the SERVOPACK may be faulty. Replace the SERVOPACK.	–

Continued on next page.

Continued from previous page.

Alarm Number: Alarm Name	Possible Cause	Confirmation	Correction	Reference
A.320: Regenerative Overload	The power supply voltage exceeded the specified range.	Measure the power supply voltage.	Set the power supply voltage within the specified range.	–
	The external regenerative resistance value or regenerative resistor capacity is too small, or there has been a continuous regeneration state.	Check the operating conditions or the capacity using the SigmaJunmaSize+ Capacity Selection Software or other means.	Change the regenerative resistance value or capacity. Reconsider the operating conditions using the SigmaJunmaSize+ Capacity Selection Software or other means.	*4
	There was a continuous regeneration state because a negative load was continuously applied.	Check the load applied to the Servomotor during operation.	Reconsider the system including the servo, machine, and operating conditions.	–
	The setting of Pn600 (Regenerative Resistor Capacity) is smaller than the capacity of the External Regenerative Resistor.	Check to see if a Regenerative Resistor is connected and check the setting of Pn600.	Correct the setting of Pn600.	*1
	The setting of Pn603 (Regenerative Resistor Capacity) is smaller than the capacity of the External Regenerative Resistor.	Check to see if a Regenerative Resistor is connected and check the setting of Pn603.	Correct the setting of Pn603.	*1
	The external regenerative resistance is too high.	Check the regenerative resistance.	Change the regenerative resistance to a correct value or use an External Regenerative Resistor of an appropriate capacity.	*4
	A failure occurred in the SERVOPACK.	–	The SERVOPACK may be faulty. Replace the SERVOPACK.	–

Continued on next page.

Continued from previous page.

Alarm Number: Alarm Name	Possible Cause	Confirmation	Correction	Reference
A.330: Main Circuit Power Supply Wiring Error (Detected when the main circuit power supply is turned ON.)	The regenerative resistor was disconnected when the SERVOPACK power supply voltage was high.	Measure the resistance of the regenerative resistor using a measuring instrument.	If you are using the regenerative resistor built into the SERVOPACK, replace the SERVOPACK. If you are using an External Regenerative Resistor, replace the External Regenerative Resistor.	–
	DC power was supplied when an AC power supply input was specified in the settings.	Check the power supply to see if it is a DC power supply.	Correct the power supply setting to match the actual power supply.	*1
	AC power was supplied when a DC power supply input was specified in the settings.	Check the power supply to see if it is an AC power supply.	Correct the power supply setting to match the actual power supply.	–
	Pn600 (Regenerative Resistor Capacity) is not set to 0 and an External Regenerative Resistor is not connected to an SGD7S-2R8A SERVOPACKs.	Check to see if an External Regenerative Resistor is connected and check the setting of Pn600.	Connect an External Regenerative Resistor, or if an External Regenerative Resistor is not required, set Pn600 to 0.	*1
	A failure occurred in the SERVOPACK.	–	The SERVOPACK may be faulty. Replace the SERVOPACK.	–
A.400: Overvoltage (Detected in the main circuit power supply section of the SERVOPACK.)	The power supply voltage exceeded the specified range.	Measure the power supply voltage.	Set the AC/DC power supply voltage within the specified range.	–
	The power supply is not stable or was influenced by a lightning surge.	Measure the power supply voltage.	Improve the power supply conditions, install a surge absorber, and then turn the power supply OFF and ON again. If an alarm still occurs, the SERVOPACK may be faulty. Replace the SERVOPACK.	–
	The voltage for AC power supply was too high during acceleration or deceleration.	Check the power supply voltage and the speed and torque during operation.	Set the AC power supply voltage within the specified range.	–
	The external regenerative resistance is too high for the operating conditions.	Check the operating conditions and the regenerative resistance.	Select a regenerative resistance value that is appropriate for the operating conditions and load.	*4
	The moment of inertia ratio or mass ratio exceeded the allowable value.	Check to see if the moment of inertia ratio or mass ratio is within the allowable range.	Increase the deceleration time, or reduce the load.	–
	A failure occurred in the SERVOPACK.	–	While the main circuit power supply is OFF, turn the control power supply to the SERVOPACK OFF and ON again. If an alarm still occurs, the SERVOPACK may be faulty. Replace the SERVOPACK.	–

Continued on next page.

Continued from previous page.

Alarm Number: Alarm Name	Possible Cause	Confirmation	Correction	Reference
A.410: Undervoltage (Detected in the main circuit power supply section of the SERVOPACK.)	The power supply voltage went below the specified range.	Measure the power supply voltage.	Set the power supply voltage within the specified range.	–
	The power supply voltage dropped during operation.	Measure the power supply voltage.	Increase the power supply capacity.	–
	A momentary power interruption occurred.	Measure the power supply voltage.	If you have changed the setting of Pn509 (Momentary Power Interruption Hold Time), decrease the setting.	*1
	The SERVOPACK fuse is blown out.	–	Replace the SERVOPACK and connect a reactor to the DC reactor terminals (⊖1 and ⊖2) on the SERVOPACK.	–
	A failure occurred in the SERVOPACK.	–	The SERVOPACK may be faulty. Replace the SERVOPACK.	–
A.510: Overspeed (The motor exceeded the maximum speed.)	The order of phases U, V, and W in the motor wiring is not correct.	Check the wiring of the Servomotor.	Make sure that the Servomotor is correctly wired.	–
	A reference value that exceeded the overspeed detection level was input.	Check the input reference.	Reduce the reference value. Or, adjust the gain.	–
	The motor exceeded the maximum speed.	Check the waveform of the motor speed.	Reduce the speed reference input gain and adjust the servo gain. Or, reconsider the operating conditions.	–
	A failure occurred in the SERVOPACK.	–	The SERVOPACK may be faulty. Replace the SERVOPACK.	–
A.511: Encoder Output Pulse Overspeed	The encoder output pulse frequency exceeded the limit.	Check the encoder output pulse setting.	Decrease the setting of Pn212 (Encoder Output Pulses) or Pn281 (Encoder Output Resolution).	*1
	The encoder output pulse frequency exceeded the limit because the motor speed was too high.	Check the encoder output pulse setting and the motor speed.	Reduce the motor speed.	–
A.520: Vibration Alarm	Abnormal oscillation was detected in the motor speed.	Check for abnormal motor noise, and check the speed and torque waveforms during operation.	Reduce the motor speed. Or, reduce the setting of Pn100 (Speed Loop Gain).	*1
	The setting of Pn103 (Moment of Inertia Ratio) is greater than the actual moment of inertia or was greatly changed.	Check the moment of inertia ratio or mass ratio.	Set Pn103 (Moment of Inertia Ratio) to an appropriate value.	*1
	The vibration detection level (Pn312 or Pn384) is not suitable.	Check that the vibration detection level (Pn312 or Pn384) is suitable.	Set a suitable vibration detection level (Pn312 or Pn384).	*1

Continued on next page.



Continued from previous page.

Alarm Number: Alarm Name	Possible Cause	Confirmation	Correction	Reference
<b>A.521:</b> Autotuning Alarm (Vibration was detected while executing the custom tuning, Easy FFT, or the tuning-less function.)	The Servomotor vibrated considerably while performing the tuning-less function.	Check the waveform of the motor speed.	Reduce the load so that the moment of inertia ratio is within the allowable value. Or increase the load level or reduce the rigidity level in the tuning-less level settings.	*1
	The Servomotor vibrated considerably while performing custom tuning or Easy FFT.	Check the waveform of the motor speed.	Check the operating procedure of corresponding function and implement corrections.	*1
<b>A.550:</b> Maximum Speed Setting Error	The setting of Pn385 (Maximum Motor Speed) is greater than the maximum speed.	Check the setting of Pn385, and the upper limits of the maximum motor speed setting and the encoder output resolution setting.	Set Pn385 to a value that does not exceed the maximum motor speed.	*1
<b>A.710:</b> Instantaneous Overload <b>A.720:</b> Continuous Overload	The wiring is not correct or there is a faulty connection in the motor or encoder wiring.	Check the wiring.	Make sure that the Servomotor and encoder are correctly wired.	*1
	Operation was performed that exceeded the overload protection characteristics.	Check the motor overload characteristics and Run command.	Reconsider the load and operating conditions. Or, increase the motor capacity.	–
	An excessive load was applied during operation because the Servomotor was not driven due to mechanical problems.	Check the operation reference and motor speed.	Correct the mechanical problem.	–
	A failure occurred in the SERVOPACK.	–	The SERVOPACK may be faulty. Replace the SERVOPACK.	–
<b>A.730 and A.731:</b> Dynamic Brake Overload (An excessive power consumption by the dynamic brake was detected.)	The Servomotor was rotated by an external force.	Check the operation status.	Implement measures to ensure that the motor will not be rotated by an external force.	–
	When the Servomotor was stopped with the dynamic brake, the rotational or linear kinetic energy exceeded the capacity of the dynamic brake resistor.	Check the power consumed by the DB resistor to see how frequently the DB is being used.	Reconsider the following: • Reduce the Servomotor command speed. • Decrease the moment of inertia ratio or mass ratio. • Reduce the frequency of stopping with the dynamic brake.	–
	A failure occurred in the SERVOPACK.	–	The SERVOPACK may be faulty. Replace the SERVOPACK.	–
<b>A.740:</b> Inrush Current Limiting Resistor Overload (The main circuit power supply was frequently turned ON and OFF.)	The allowable frequency of the inrush current limiting resistor was exceeded when the main circuit power supply was turned ON and OFF.	–	Reduce the frequency of turning the main circuit power supply ON and OFF.	–
	A failure occurred in the SERVOPACK.	–	The SERVOPACK may be faulty. Replace the SERVOPACK.	–

Continued on next page.

Continued from previous page.

Alarm Number: Alarm Name	Possible Cause	Confirmation	Correction	Reference
<b>A.7A1:</b> Internal Temperature Error 1 (Control Board Temperature Error)	The surrounding temperature is too high.	Check the surrounding temperature using a thermostat. Or, check the operating status with the SERVOPACK installation environment monitor.	Decrease the surrounding temperature by improving the SERVOPACK installation conditions.	*1
	An overload alarm was reset by turning OFF the power supply too many times.	Check the alarm display to see if there is an overload alarm.	Change the method for resetting the alarm.	–
	There was an excessive load or operation was performed that exceeded the regenerative processing capacity.	Use the accumulated load ratio to check the load during operation, and use the regenerative load ratio to check the regenerative processing capacity.	Reconsider the load and operating conditions.	–
	The SERVOPACK installation orientation is not correct or there is insufficient space around the SERVOPACK.	Check the SERVOPACK installation conditions.	Install the SERVOPACK according to specifications.	*1
	A failure occurred in the SERVOPACK.	–	The SERVOPACK may be faulty. Replace the SERVOPACK.	–
<b>A.7A2:</b> Internal Temperature Error 2 (Power Board Temperature Error)	The surrounding temperature is too high.	Check the surrounding temperature using a thermostat. Or, check the operating status with the SERVOPACK installation environment monitor.	Decrease the surrounding temperature by improving the SERVOPACK installation conditions.	*1
	An overload alarm was reset by turning OFF the power supply too many times.	Check the alarm display to see if there is an overload alarm.	Change the method for resetting the alarm.	–
	There was an excessive load or operation was performed that exceeded the regenerative processing capacity.	Use the accumulated load ratio to check the load during operation, and use the regenerative load ratio to check the regenerative processing capacity.	Reconsider the load and operating conditions.	–
	The SERVOPACK installation orientation is not correct or there is insufficient space around the SERVOPACK.	Check the SERVOPACK installation conditions.	Install the SERVOPACK according to specifications.	*1
	A failure occurred in the SERVOPACK.	–	The SERVOPACK may be faulty. Replace the SERVOPACK.	–
<b>A.7A3:</b> Internal Temperature Sensor Error (An error occurred in the temperature sensor circuit.)	A failure occurred in the SERVOPACK.	–	The SERVOPACK may be faulty. Replace the SERVOPACK.	–

Continued on next page.

Continued from previous page.

Alarm Number: Alarm Name	Possible Cause	Confirmation	Correction	Reference
A.7Ab: SERVOPACK Built-in Fan Stopped	The fan inside the SERVOPACK stopped.	Check for foreign matter inside the SERVOPACK.	Remove foreign matter from the SERVOPACK. If an alarm still occurs, the SERVOPACK may be faulty. Replace the SERVOPACK.	–
A.810: Encoder Backup Alarm (Detected at the encoder, but only when an absolute encoder is used.)	The power to the absolute encoder was turned ON for the first time.	Check to see if the power supply was turned ON for the first time.	Set up the encoder.	
	The Encoder Cable was disconnected and then connected again.	Check to see if the power supply was turned ON for the first time.	Check the encoder connection and set up the encoder.	*1
	Power is not being supplied both from the control power supply (+5 V) from the SERVOPACK and from the battery power supply.	Check the encoder connector battery and the connector status.	Replace the battery or implement similar measures to supply power to the encoder, and set up the encoder.	
	A failure occurred in the absolute encoder.	–	If the alarm still occurs after setting up the encoder again, replace the Servomotor.	–
A.820: Encoder Check-sum Alarm (Detected at the encoder.)	A failure occurred in the encoder.	–	<ul style="list-style-type: none"> <li>■ When Using an Absolute Encoder Set up the encoder again. If the alarm still occurs, the Servomotor may be faulty. Replace the Servomotor.</li> <li>■ When Using a Single-turn Absolute Encoder or Incremental Encoder The Servomotor may be faulty. Replace the Servomotor.</li> </ul>	*1
	A failure occurred in the SERVOPACK.	–	The SERVOPACK may be faulty. Replace the SERVOPACK.	–
A.830: Encoder Battery Alarm (The absolute encoder battery voltage was lower than the specified level.)	The battery connection is faulty or a battery is not connected.	Check the battery connection.	Correct the battery connection.	*1
	The battery voltage is lower than the specified value (2.7 V).	Measure the battery voltage.	Replace the battery.	*1
	A failure occurred in the SERVOPACK.	–	The SERVOPACK may be faulty. Replace the SERVOPACK.	–

Continued on next page.

Continued from previous page.

Alarm Number: Alarm Name	Possible Cause	Confirmation	Correction	Reference
A.840: Encoder Data Alarm (Detected at the encoder.)	The encoder malfunctioned.	—	Turn the power supply to the SERVOPACK OFF and ON again. If an alarm still occurs, the Servomotor may be faulty. Replace the Servomotor.	—
	The encoder malfunctioned due to noise.	—	Correct the wiring around the encoder by separating the Encoder Cable from the Servomotor Main Circuit Cable or by grounding the encoder.	—
A.850: Encoder Over- speed (Detected at the encoder when the control power supply is turned ON.)	The Servomotor speed was 200 min <sup>-1</sup> or higher when the control power supply was turned ON.	Check the motor speed when the power supply is turned ON.	Reduce the Servomotor speed to a value less than 200 min <sup>-1</sup> , and turn ON the control power supply.	—
	A failure occurred in the encoder.	—	Turn the power supply to the SERVOPACK OFF and ON again. If an alarm still occurs, the Servomotor may be faulty. Replace the Servomotor.	—
	A failure occurred in the SERVOPACK.	—	Turn the power supply to the SERVOPACK OFF and ON again. If an alarm still occurs, the SERVOPACK may be faulty. Replace the SERVOPACK.	—
A.860: Encoder Over- heated (Detected at the encoder.)	The surrounding air temperature around the Servomotor is too high.	Measure the surrounding air temperature around the Servomotor.	Reduce the surrounding air temperature of the Servomotor to 40°C or less.	—
	The Servomotor load is greater than the rated load.	Use the accumulated load ratio to check the load.	Operate the Servo Drive so that the motor load remains within the specified range.	*1
	A failure occurred in the encoder.	—	Turn the power supply to the SERVOPACK OFF and ON again. If an alarm still occurs, the Servomotor may be faulty. Replace the Servomotor.	—
	A failure occurred in the SERVOPACK.	—	Turn the power supply to the SERVOPACK OFF and ON again. If an alarm still occurs, the SERVOPACK may be faulty. Replace the SERVOPACK.	—

Continued on next page.

Continued from previous page.

Alarm Number: Alarm Name	Possible Cause	Confirmation	Correction	Reference
A.861: Motor Over- heated	The surrounding temperature around the Servomotor is too high.	Measure the surrounding temperature around the Servomotor.	Reduce the surrounding air temperature of the Servomotor to 40°C or less.	–
	The motor load is greater than the rated load.	Check the load with the accumulated load ratio on the Motion Monitor Tab Page on the SigmaWin+.	Operate the Servo Drive so that the motor load remains within the specified range.	*1
	A failure occurred in the Serial Converter Unit.	–	Turn the power supply to the SERVOPACK OFF and ON again. If an alarm still occurs, the Serial Converter Unit may be faulty. Replace the Serial Converter Unit.	–
	A failure occurred in the SERVOPACK.	–	Turn the power supply to the SERVOPACK OFF and ON again. If an alarm still occurs, the SERVOPACK may be faulty. Replace the SERVOPACK.	–
A.862: Overheat Alarm	The surrounding temperature is too high.	Check the surrounding temperature using a thermostat.	Lower the surrounding temperature by improving the installation conditions of the machine.	–
	The overheat protection input signal line is disconnected or short-circuited.	Check the input voltage with the overheat protection input information on the Motion Monitor Tab Page on the SigmaWin+.	Repair the line for the overheat protection input signal.	–
	An overload alarm was reset by turning OFF the power supply too many times.	Check the alarm display to see if there is an overload alarm.	Change the method for resetting the alarm.	–
	Operation was performed under an excessive load.	Use the accumulated load ratio to check the load during operation.	Reconsider the load and operating conditions.	–
	A failure occurred in the SERVOPACK.	–	The SERVOPACK may be faulty. Replace the SERVOPACK.	–
	The sensor attached to the machine is faulty.	–	The sensor attached to the machine may be faulty. Repair the sensor attached to the machine.	–
A.8A0: External Encoder Error	Setting the origin of the absolute linear encoder failed because the motor moved.	Before you set the origin, use the fully-closed feedback pulse counter to confirm that the motor is not moving.	The motor must be stopped while setting the origin position.	*1
	A failure occurred in the external encoder.	–	Replace the external encoder.	–
A.8A1: External Encoder Module Error	A failure occurred in the external encoder.	–	Replace the external encoder.	–
	A failure occurred in the Serial Converter Unit.	–	Replace the Serial Converter Unit.	–

Continued on next page.

Continued from previous page.

Alarm Number: Alarm Name	Possible Cause	Confirmation	Correction	Reference
<b>A.8A2:</b> External Incremental Encoder Sensor Error	A failure occurred in the external encoder.	–	Replace the external encoder.	–
<b>A.8A3:</b> External Absolute Encoder Position Error	A failure occurred in the external absolute encoder.	–	The external absolute encoder may be faulty. Refer to the encoder manufacturer's instruction manual for corrections.	–
<b>A.8A5:</b> External Encoder Overspeed	An overspeed error was detected in the external encoder.	Check the maximum speed of the external encoder.	Keep the external encoder below its maximum speed.	–
<b>A.8A6:</b> External Encoder Overheated	An overheating error was detected in the external encoder.	–	Replace the external encoder.	–
<b>A.b33:</b> Current Detection Error 3	A failure occurred in the current detection circuit.	–	Turn the power supply to the SERVOPACK OFF and ON again. If an alarm still occurs, the SERVOPACK may be faulty. Replace the SERVOPACK.	–
<b>A.b6A:</b> MECHATROLINK Communications ASIC Error 1	There is a fault in the SERVOPACK MECHATROLINK communications section.	–	Turn the power supply to the SERVOPACK OFF and ON again. If an alarm still occurs, the SERVOPACK may be faulty. Replace the SERVOPACK.	–
<b>A.b6b:</b> MECHATROLINK Communications ASIC Error 2	A malfunction occurred in the MECHATROLINK communications section due to noise.	–	Implement the following countermeasures against noise. <ul style="list-style-type: none"> <li>• Check the MECHATROLINK Communications Cable and FG wiring.</li> <li>• Attach a ferrite core to the MECHATROLINK Communications Cable.</li> </ul>	–
	There is a fault in the SERVOPACK MECHATROLINK communications section.	–	Turn the power supply to the SERVOPACK OFF and ON again. If an alarm still occurs, the SERVOPACK may be faulty. Replace the SERVOPACK.	–
<b>A.bF0:</b> System Alarm 0	A failure occurred in the SERVOPACK.	–	Turn the power supply to the SERVOPACK OFF and ON again. If an alarm still occurs, the SERVOPACK may be faulty. Replace the SERVOPACK.	–
<b>A.bF1:</b> System Alarm 1	A failure occurred in the SERVOPACK.	–	Turn the power supply to the SERVOPACK OFF and ON again. If an alarm still occurs, the SERVOPACK may be faulty. Replace the SERVOPACK.	–
<b>A.bF2:</b> System Alarm 2	A failure occurred in the SERVOPACK.	–	Turn the power supply to the SERVOPACK OFF and ON again. If an alarm still occurs, the SERVOPACK may be faulty. Replace the SERVOPACK.	–

Continued on next page.

Continued from previous page.

Alarm Number: Alarm Name	Possible Cause	Confirmation	Correction	Reference
A.bF3: System Alarm 3	A failure occurred in the SERVOPACK.	–	Turn the power supply to the SERVOPACK OFF and ON again. If an alarm still occurs, the SERVOPACK may be faulty. Replace the SERVOPACK.	–
A.bF4: System Alarm 4	A failure occurred in the SERVOPACK.	–	Turn the power supply to the SERVOPACK OFF and ON again. If an alarm still occurs, the SERVOPACK may be faulty. Replace the SERVOPACK.	–
A.bF5: System Alarm 5	A failure occurred in the SERVOPACK.	–	Turn the power supply to the SERVOPACK OFF and ON again. If an alarm still occurs, the SERVOPACK may be faulty. Replace the SERVOPACK.	–
A.bF6: System Alarm 6	A failure occurred in the SERVOPACK.	–	Turn the power supply to the SERVOPACK OFF and ON again. If an alarm still occurs, the SERVOPACK may be faulty. Replace the SERVOPACK.	–
A.bF7: System Alarm 7	A failure occurred in the SERVOPACK.	–	Turn the power supply to the SERVOPACK OFF and ON again. If an alarm still occurs, the SERVOPACK may be faulty. Replace the SERVOPACK.	–
A.bF8: System Alarm 8	A failure occurred in the SERVOPACK.	–	Turn the power supply to the SERVOPACK OFF and ON again. If an alarm still occurs, the SERVOPACK may be faulty. Replace the SERVOPACK.	–
A.C10: Servomotor Out of Control (Detected when the servo is turned ON.)	The order of phases U, V, and W in the motor wiring is not correct.	Check the Servomotor wiring.	Make sure that the Servomotor is correctly wired.	–
	A failure occurred in the encoder.	–	If the motor wiring is correct and an alarm still occurs after turning the power supply OFF and ON again, the Servomotor may be faulty. Replace the Servomotor.	–
	A failure occurred in the SERVOPACK.	–	Turn the power supply to the SERVOPACK OFF and ON again. If an alarm still occurs, the SERVOPACK may be faulty. Replace the SERVOPACK.	–

Continued on next page.

Continued from previous page.

Alarm Number: Alarm Name	Possible Cause	Confirmation	Correction	Reference
A.C80: Encoder Clear Error or Multiturn Limit Setting Error	A failure occurred in the encoder.	—	Turn the power supply to the SERVOPACK OFF and ON again. If an alarm still occurs, the Servomotor may be faulty. Replace the Servomotor.	—
	A failure occurred in the SERVOPACK.	—	Turn the power supply to the SERVOPACK OFF and ON again. If an alarm still occurs, the SERVOPACK may be faulty. Replace the SERVOPACK.	—
A.C90: Encoder Commu- nications Error	There is a faulty contact in the connector or the connector is not wired correctly for the encoder.	Check the condition of the encoder connector.	Reconnect the encoder connector and check the encoder wiring.	*1
	There is a cable disconnection or short-circuit in the encoder. Or, the cable impedance is outside the specified values.	Check the condition of the Encoder Cable.	Use the Encoder Cable within the specified specifications.	—
	One of the following has occurred: corrosion caused by improper temperature, humidity, or gas, a short-circuit caused by entry of water drops or cutting oil, or faulty contact in connector caused by vibration.	Check the operating environment.	Improve the operating environmental, and replace the cable. If the alarm still occurs, replace the SERVOPACK.	*1
	A malfunction was caused by noise.	—	Correct the wiring around the encoder by separating the Encoder Cable from the Servomotor Main Circuit Cable or by grounding the encoder.	*1
	A failure occurred in the SERVOPACK.	—	Connect the Servomotor to another SERVOPACK, and turn ON the control power supply. If no alarm occurs, the SERVOPACK may be faulty. Replace the SERVOPACK.	—
A.C91: Encoder Commu- nications Posi- tion Data Acceleration Rate Error	Noise entered on the signal lines because the Encoder Cable is bent or the sheath is damaged.	Check the condition of the Encoder Cable and connectors.	Check the Encoder Cable to see if it is installed correctly.	*1
	The Encoder Cable is bundled with a high-current line or installed near a high-current line.	Check the installation condition of the Encoder Cable.	Confirm that there is no surge voltage on the Encoder Cable.	—
	There is variation in the FG potential because of the influence of machines on the Servomotor side, such as a welder.	Check the installation condition of the Encoder Cable.	Properly ground the machine to separate it from the FG of the encoder.	—

Continued on next page.



Continued from previous page.

Alarm Number: Alarm Name	Possible Cause	Confirmation	Correction	Reference
A.C92: Encoder Commu- nications Timer Error	Noise entered on the signal line from the encoder.	–	Implement countermeasures against noise for the encoder wiring.	*1
	Excessive vibration or shock was applied to the encoder.	Check the operating conditions.	Reduce machine vibration. Correctly install the Servomotor.	–
	A failure occurred in the encoder.	–	Turn the power supply to the SERVOPACK OFF and ON again. If an alarm still occurs, the Servomotor may be faulty. Replace the Servomotor.	–
	A failure occurred in the SERVOPACK.	–	Turn the power supply to the SERVOPACK OFF and ON again. If an alarm still occurs, the SERVOPACK may be faulty. Replace the SERVOPACK.	–
A.CA0: Encoder Parame- ter Error	A failure occurred in the encoder.	–	Turn the power supply to the SERVOPACK OFF and ON again. If an alarm still occurs, the Servomotor may be faulty. Replace the Servomotor.	–
	A failure occurred in the SERVOPACK.	–	Turn the power supply to the SERVOPACK OFF and ON again. If an alarm still occurs, the SERVOPACK may be faulty. Replace the SERVOPACK.	–

Continued on next page.

Continued from previous page.

Alarm Number: Alarm Name	Possible Cause	Confirmation	Correction	Reference
A.Cb0: Encoder Echo- back Error	The encoder is wired incorrectly or there is faulty contact.	Check the wiring of the encoder.	Make sure that the encoder is correctly wired.	*1
	The specifications of the Encoder Cable are not correct and noise entered on it.	–	Use a shielded twisted-pair wire cable or a screened twisted-pair cable with conductors of at least 0.12 mm <sup>2</sup> .	–
	The Encoder Cable is too long and noise entered on it.	–	The Encoder Cable wiring distance must be 50 m max.	–
	There is variation in the FG potential because of the influence of machines on the Servomotor side, such as a welder.	Check the condition of the Encoder Cable and connectors.	Properly ground the machine to separate it from the FG of the encoder.	–
	Excessive vibration or shock was applied to the encoder.	Check the operating conditions.	Reduce machine vibration. Correctly install the Servomotor.	–
	A failure occurred in the encoder.	–	Turn the power supply to the SERVOPACK OFF and ON again. If an alarm still occurs, the Servomotor may be faulty. Replace the Servomotor.	–
	A failure occurred in the SERVOPACK.	–	Turn the power supply to the SERVOPACK OFF and ON again. If an alarm still occurs, the SERVOPACK may be faulty. Replace the SERVOPACK.	–
A.CC0: Multiturn Limit Disagreement	When using a Direct Drive Servomotor, the setting of Pn205 (Multiturn Limit Setting) does not agree with the encoder.	Check the setting of Pn205.	Correct the setting of Pn205 (0 to 65,535).	*1
	The multiturn limit of the encoder is different from that of the SERVOPACK. Or, the multiturn limit of the SERVOPACK has been changed.	Check the setting of Pn205 in the SERVOPACK.	Change the setting if the alarm occurs.	*1
	A failure occurred in the SERVOPACK.	–	Turn the power supply to the SERVOPACK OFF and ON again. If an alarm still occurs, the SERVOPACK may be faulty. Replace the SERVOPACK.	–

Continued on next page.

Continued from previous page.

Alarm Number: Alarm Name	Possible Cause	Confirmation	Correction	Reference
<b>A.CF1:</b> Reception Failed Error in Feed- back Option Module Commu- nications	The cable between the Serial Converter Unit and SERVOPACK is not wired correctly or there is a faulty contact.	Check the wiring of the external encoder.	Correctly wire the cable between the Serial Converter Unit and SERVOPACK.	*1
	A specified cable is not being used between Serial Converter Unit and SERVOPACK.	Check the wiring specifications of the external encoder.	Use a specified cable.	-
	The cable between the Serial Converter Unit and SERVOPACK is too long.	Measure the length of the cable that connects the Serial Converter Unit.	The length of the cable between the Serial Converter Unit and SERVOPACK must be 20 m or less.	-
	The sheath on cable between the Serial Converter Unit and SERVOPACK is broken.	Check the cable that connects the Serial Converter Unit.	Replace the cable between the Serial Converter Unit and SERVOPACK.	-
<b>A.CF2:</b> Timer Stopped Error in Feed- back Option Module Commu- nications	Noise entered the cable between the Serial Converter Unit and SERVOPACK.	-	Correct the wiring around the Serial Converter Unit, e.g., separate I/O signal lines from the Main Circuit Cables or ground.	-
	A failure occurred in the Serial Converter Unit.	-	Replace the Serial Converter Unit.	-
	A failure occurred in the SERVOPACK.	-	Replace the SERVOPACK.	-
<b>A.d00:</b> Position Devia- tion Overflow (The setting of Pn520 (Exces- sive Position Deviation Alarm Level) was exceeded by the position devia- tion while the servo was ON.)	The Servomotor U, V, and W wiring is not correct.	Check the wiring of the Servomotor's Main Circuit Cables.	Make sure that there are no faulty contacts in the wiring for the Servomotor and encoder.	-
	The position command speed is too fast.	Reduce the position command speed and try operating the SERVOPACK.	Reduce the position reference speed or the reference acceleration rate, or reconsider the electronic gear ratio.	*1
	The acceleration of the position reference is too high.	Reduce the reference acceleration and try operating the SERVOPACK.	Reduce the acceleration of the position reference using a MECHATROLINK command. Or, smooth the position reference acceleration by selecting the position reference filter (ACCFIL) using a MECHATROLINK command.	-
	The setting of Pn520 (Excessive Position Deviation Alarm Level) is too low for the operating conditions.	Check Pn520 (Excessive Position Deviation Alarm Level) to see if it is set to an appropriate value.	Optimize the setting of Pn520.	*1
	A failure occurred in the SERVOPACK.	-	Turn the power supply to the SERVOPACK OFF and ON again. If an alarm still occurs, the SERVOPACK may be faulty. Replace the SERVOPACK.	-

Continued on next page.

Continued from previous page.

Alarm Number: Alarm Name	Possible Cause	Confirmation	Correction	Reference
A.d01: Position Deviation Overflow Alarm at Servo ON	The servo was turned ON after the position deviation exceeded the setting of Pn526 (Excessive Position Deviation Alarm Level at Servo ON) while the servo was OFF.	Check the position deviation while the servo is OFF.	Optimize the setting of Pn526 (Excessive Position Deviation Alarm Level at Servo ON).	
A.d02: Position Deviation Overflow Alarm for Speed Limit at Servo ON	If position deviation remains in the deviation counter, the setting of Pn529 or Pn584 (Speed Limit Level at Servo ON) limits the speed when the servo is turned ON. This alarm occurs if a position reference is input and the setting of Pn520 (Excessive Position Deviation Alarm Level) is exceeded.	–	Optimize the setting of Pn520 (Excessive Position Deviation Alarm Level). Or, adjust the setting of Pn529 or Pn584 (Speed Limit Level at Servo ON).	*1
A.d10: Motor-Load Position Deviation Overflow	The motor direction and external encoder installation orientation are backward.	Check the motor direction and the external encoder installation orientation.	Install the external encoder in the opposite direction, or change the setting of Pn002 = n.X□□□ (External Encoder Usage) to reverse the direction.	*1
	There is an error in the connection between the load (e.g., stage) and external encoder coupling.	Check the coupling of the external encoder.	Check the mechanical coupling.	–
A.d30: Position Data Overflow	The position data exceeded $\pm 1,879,048,192$ .	Check the input reference pulse counter.	Reconsider the operating specifications.	–
A.E02: MECHATROLINK Internal Synchronization Error 1	The MECHATROLINK transmission cycle fluctuated.	–	Remove the cause of transmission cycle fluctuation at the host controller.	–
	A failure occurred in the SERVOPACK.	–	Turn the power supply to the SERVOPACK OFF and ON again. If an alarm still occurs, the SERVOPACK may be faulty. Replace the SERVOPACK.	–
A.E40: MECHATROLINK Transmission Cycle Setting Error	The setting of MECHATROLINK transmission cycle is outside of the specified range.	Check the setting of the MECHATROLINK transmission cycle.	Set the MECHATROLINK transmission cycle to an appropriate value.	–
A.E41: MECHATROLINK Communications Data Size Setting Error	The number of transmission bytes set on DIP switch S3 is not correct.	Check the MECHATROLINK communications data size of the host controller.	Reset DIP switch S3 to change the number of transmission bytes to an appropriate value.	*1

Continued on next page.

Continued from previous page.

Alarm Number: Alarm Name	Possible Cause	Confirmation	Correction	Reference
A.E42: MECHATROLINK Station Address Setting Error	The station address is outside of the setting range.	Check rotary switches S1 and S2 to see if the station address is between 03 and EF.	Check the setting of the station address of the host controller, and reset rotary switches S1 and S2 to change the address to an appropriate value between 03 and EF.	*1
	Two or more stations on the communications network have the same address.	Check to see if two or more stations on the communications network have the same address.	Check the setting of the station address of the host controller, and reset rotary switches S1 and S2 to change the address to an appropriate value between 03 and EF.	
A.E50*5: MECHATROLINK Synchronization Error	The WDT data in the host controller was not updated normally.	Check to see if the WDT data is being updated at the host controller.	Correctly update the WDT data at the host controller.	-
	A failure occurred in the SERVOPACK.	-	Turn the power supply to the SERVOPACK OFF and ON again. If an alarm still occurs, the SERVOPACK may be faulty. Replace the SERVOPACK.	-
A.E51: MECHATROLINK Synchronization Failed	The WDT data at the host controller was not updated correctly at the start of synchronous communications, so synchronous communications could not be started.	Check to see if the WDT data is being updated in the host controller.	Correctly update the WDT data at the host controller.	-
	A failure occurred in the SERVOPACK.	-	Turn the power supply to the SERVOPACK OFF and ON again. If an alarm still occurs, the SERVOPACK may be faulty. Replace the SERVOPACK.	-
A.E60*5: Reception Error in MECHATROLINK Communications	MECHATROLINK wiring is not correct.	Check the MECHATROLINK wiring.	Correct the MECHATROLINK Communications Cable wiring.	-
	A MECHATROLINK data reception error occurred due to noise.	-	Implement countermeasures against noise. (Check the MECHATROLINK Communications Cable and FG wiring, and implement measures such as attaching a ferrite core to the MECHATROLINK Communications Cable.)	-
	A failure occurred in the SERVOPACK.	-	Turn the power supply to the SERVOPACK OFF and ON again. If an alarm still occurs, the SERVOPACK may be faulty. Replace the SERVOPACK.	-

Continued on next page.

Continued from previous page.

Alarm Number: Alarm Name	Possible Cause	Confirmation	Correction	Reference
A.E61: Synchronization Interval Error in MECHATROLINK Transmission Cycle	The MECHATROLINK transmission cycle fluctuated.	Check the setting of the MECHATROLINK transmission cycle.	Remove the cause of transmission cycle fluctuation at the host controller.	-
	A failure occurred in the SERVOPACK.	-	Turn the power supply to the SERVOPACK OFF and ON again. If an alarm still occurs, the SERVOPACK may be faulty. Replace the SERVOPACK.	-
A.E63: MECHATROLINK Synchronization Frame Not Received	MECHATROLINK wiring is not correct.	Check the Servomotor wiring.	Correct the MECHATROLINK Communications Cable wiring.	-
	A MECHATROLINK data reception error occurred due to noise.	-	Implement countermeasures against noise. (Check the MECHATROLINK Communications Cable and FG wiring, and implement measures such as attaching a ferrite core to the MECHATROLINK Communications Cable.)	-
	A failure occurred in the SERVOPACK.	-	Turn the power supply to the SERVOPACK OFF and ON again. If an alarm still occurs, the SERVOPACK may be faulty. Replace the SERVOPACK.	-
A.E71: Safety Option Module Detection Failure	There is a faulty connection between the SERVOPACK and the Safety Option Module.	Check the connection between the SERVOPACK and the Safety Option Module.	Correctly connect the Safety Option Module.	-
	The Safety Option Module was disconnected.	-	Execute Fn014 (Reset Option Module Configuration Error) from the Digital Operator or SigmaWin+ and then turn the power supply to the SERVOPACK OFF and ON again.	*1
	A failure occurred in the Safety Option Module.	-	Replace the Safety Option Module.	-
	A failure occurred in the SERVOPACK.	-	Replace the SERVOPACK.	-
A.E72: Feedback Option Module Detection Failure	There is a faulty connection between the SERVOPACK and the Feedback Option Module.	Check the connection between the SERVOPACK and the Feedback Option Module.	Correctly connect the Feedback Option Module.	-
	The Feedback Option Module was disconnected.	-	Reset the Option Module configuration error and turn the power supply to the SERVOPACK OFF and ON again.	*1
	A failure occurred in the Feedback Option Module.	-	Replace the Feedback Option Module.	-
	A failure occurred in the SERVOPACK.	-	Replace the SERVOPACK.	-

Continued on next page.

Continued from previous page.

Alarm Number: Alarm Name	Possible Cause	Confirmation	Correction	Reference
A.E74: Unsupported Safety Option Module	A failure occurred in the Safety Option Module.	–	Replace the Safety Option Module.	–
	An unsupported Safety Option Module was connected.	Refer to the catalog of the connected Safety Option Module.	Connect a compatible Safety Option Module.	–
A.Eb1: Safety Function Signal Input Tim- ing Error	The delay between activation of the /HWBB1 and /HWBB2 input signals for the HWBB was ten second or longer.	Measure the time delay between the /HWBB1 and /HWBB2 signals.	The output signal circuits or devices for /HWBB1 and /HWBB2 or the SERVOPACK input signal circuits may be faulty. Alternatively, the input signal cables may be disconnected. Check to see if any of these items are faulty or have been disconnected.	–
	A failure occurred in the SERVOPACK.	–	Replace the SERVOPACK.	–
A.EC8: Gate Drive Error 1 (An error occurred in the gate drive circuit.)	A failure occurred in the SERVOPACK.	–	Turn the power supply to the SERVOPACK OFF and ON again. If an alarm still occurs, the SERVOPACK may be faulty. Replace the SERVOPACK.	–
A.EC9: Gate Drive Error 2 (An error occurred in the gate drive circuit.)				
A.Ed1: Command Exe- cution Timeout	A timeout error occurred for a MECHATROLINK command.	Check the motor status when the command is executed.	Execute the SV_ON or SENS_ON command only when the motor is not operating.	–
		For fully-closed loop control, check the status of the external encoder when the command is executed.	Execute the SENS_ON command only when an external encoder is connected.	–
A.F10: Power Supply Line Open Phase (The voltage was low for more than one second for phase R, S, or T when the main power supply was ON.)	The three-phase power supply wiring is not correct.	Check the power supply wiring.	Make sure that the power supply is correctly wired.	*1
	The three-phase power supply is unbalanced.	Measure the voltage for each phase of the three-phase power supply.	Balance the power supply by changing phases.	–
	A single-phase power supply was input without specifying a single-phase AC power supply input (Pn00B = n.□1□□).	Check the power supply and the parameter setting.	Match the parameter setting to the power supply.	*1
	A failure occurred in the SERVOPACK.	–	Turn the power supply to the SERVOPACK OFF and ON again. If an alarm still occurs, the SERVOPACK may be faulty. Replace the SERVOPACK.	–

Continued on next page.

Continued from previous page.

Alarm Number: Alarm Name	Possible Cause	Confirmation	Correction	Reference
FL-1*5: System Alarm	A failure occurred in the SERVOPACK.	-	Turn the power supply to the SERVOPACK OFF and ON again. If an alarm still occurs, the SERVOPACK may be faulty. Replace the SERVOPACK.	-
FL-2*5: System Alarm				
FL-3*5: System Alarm				
FL-4*5: System Alarm				
FL-5*5: System Alarm				
FL-6*5: System Alarm				
CPF00: Digital Operator Communications Error 1	There is a faulty contact between the Digital Operator and the SERVOPACK.	Check the connector contact.	Disconnect the connector and insert it again. Or, replace the cable.	-
	A malfunction was caused by noise.	-	Keep the Digital Operator or the cable away from sources of noise.	-
CPF01: Digital Operator Communications Error 2	A failure occurred in the Digital Operator.	-	Disconnect the Digital Operator and then connect it again. If an alarm still occurs, the Digital Operator may be faulty. Replace the Digital Operator.	-
	A failure occurred in the SERVOPACK.	-	Turn the power supply to the SERVOPACK OFF and ON again. If an alarm still occurs, the SERVOPACK may be faulty. Replace the SERVOPACK.	-

\*1. Refer to the following manual for details.

 Σ-7-Series Σ-7S SERVOPACK with MECHATROLINK-III Communications References Product Manual (Manual No.: SIEP S800001 28)

 Σ-7-Series Σ-7S SERVOPACK with MECHATROLINK-III Communications References and RJ-45 Connectors Product Manual (Manual No.: SIEP S800001 62)

\*2. Detection Conditions

If either of the following conditions is detected, an alarm will occur.

- $Pn533 \text{ [min}^{-1}] \times \frac{\text{Encoder resolution}}{6 \times 10^5} \leq \frac{Pn20E}{Pn210}$

- $\text{Maximum motor speed [min}^{-1}] \times \frac{\text{Encoder resolution}}{\text{Approx. } 3.66 \times 10^{12}} \geq \frac{Pn20E}{Pn210}$

\*3. Detection Conditions

If either of the following conditions is detected, an alarm will occur.

- $\text{Rated motor speed [min}^{-1}] \times 1/3 \times \frac{\text{Encoder resolution}}{6 \times 10^5} \leq \frac{Pn20E}{Pn210}$

- $\text{Maximum motor speed [min}^{-1}] \times \frac{\text{Encoder resolution}}{\text{Approx. } 3.66 \times 10^{12}} \geq \frac{Pn20E}{Pn210}$

\*4. Refer to the following manual for details.

 Σ-7-Series Peripheral Device Selection Manual (Manual No.: SIEP S800001 32)

\*5. These alarms are not stored in the alarm history. They are only displayed on the panel display.



## 5.4 Warning Displays

If a warning occurs in the SERVOPACK, a warning number will be displayed on the panel display. Warnings are displayed to warn you before an alarm occurs.

## 5.5 List of Warnings

The list of warnings gives the warning name and warning meaning in order of the warning numbers.

Warning Number	Warning Name	Meaning	Resetting
A.900	Position Deviation Overflow	The position deviation exceeded the percentage set with the following formula: (Pn520 × Pn51E/100)	Required.
A.901	Position Deviation Overflow Alarm at Servo ON	The position deviation when the servo was turned ON exceeded the percentage set with the following formula: (Pn526 × Pn528/100)	Required.
A.910	Overload	This warning occurs before an overload alarm (A.710 or A.720) occurs. If the warning is ignored and operation is continued, an alarm may occur.	Required.
A.911	Vibration	Abnormal vibration was detected during motor operation. The detection level is the same as A.520. Set whether to output an alarm or a warning by setting Pn310 (Vibration Detection Switch).	Required.
A.912	Internal Temperature Warning 1 (Control Board Temperature Error)	The surrounding temperature of the control PCB is abnormal.	Required.
A.913	Internal Temperature Warning 2 (Power Board Temperature Error)	The surrounding temperature of the power PCB is abnormal.	Required.
A.920	Regenerative Overload	This warning occurs before an A.320 alarm (Regenerative Overload) occurs. If the warning is ignored and operation is continued, an alarm may occur.	Required.
A.921	Dynamic Brake Overload	This warning occurs before an A.731 alarm (Dynamic Brake Overload) occurs. If the warning is ignored and operation is continued, an alarm may occur.	Required.
A.923	SERVOPACK Built-in Fan Stopped	The fan inside the SERVOPACK stopped.	Required.
A.930	Absolute Encoder Battery Error	This warning occurs when the voltage of absolute encoder's battery is low.	Required.
A.93B	Overheat Warning	The input voltage (temperature) for the overheat protection input (TH) signal exceeded the setting of Pn61C (Overheat Warning Level).	Required.
A.942	Speed Ripple Compensation Information Disagreement	The speed ripple compensation information stored in the encoder does not agree with the speed ripple compensation information stored in the SERVOPACK.	Required.
A.94A	Data Setting Warning 1 (Parameter Number Error)	There is an error in the parameter number for a Data Setting Warning 1 (Parameter Number) command.	Automatically reset.*
A.94b	Data Setting Warning 2 (Out of Range)	The command data is out of range.	Automatically reset.*
A.94C	Data Setting Warning 3 (Calculation Error)	A calculation error was detected.	Automatically reset.*
A.94d	Data Setting Warning 4 (Parameter Size)	The data sizes do not match.	Automatically reset.*
A.94E	Data Setting Warning 5 (Latch Mode Error)	A latch mode error was detected.	Required.
A.95A	Command Warning 1 (Unsatisfied Command Conditions)	A command was sent when the conditions for sending a command were not satisfied.	Automatically reset.*

Continued on next page.

Continued from previous page.

Warning Number	Warning Name	Meaning	Resetting
A.95b	Command Warning 2 (Unsupported Command)	An unsupported command was sent.	Automatically reset.*
A.95d	Command Warning 4 (Command Interference)	There was command interference, particularly latch command interference.	Automatically reset.*
A.95E	Command Warning 5 (Subcommand Not Possible)	The subcommand and main command interfere with each other.	Automatically reset.*
A.95F	Command Warning 6 (Undefined Command)	An undefined command was sent.	Automatically reset.*
A.960	MECHATROLINK Communications Warning	A communications error occurred during MECHATROLINK communications.	Required.
A.971	Undervoltage	This warning occurs before an A.410 alarm (Undervoltage) occurs. If the warning is ignored and operation is continued, an alarm may occur.	Required.
A.97A	Command Warning 7 (Phase Error)	A command that cannot be executed in the current phase was sent.	Automatically reset.*
A.97b	Data Clamp Out of Range	The set command data was clamped to the minimum or maximum value of the allowable setting range.	Automatically reset.*
A.9A0	Overtravel	Overtravel was detected while the servo was ON.	Required.
A.9b0	Preventative Maintenance Warning	One of the consumable parts has reached the end of its service life.	Required.

\* If using the commands for the MECHATROLINK-III standard servo profile, the warning will automatically be cleared after the correct command is received. If you use MECHATROLINK-II-compatible profile commands, send an ALM\_CLR (Clear Warning or Alarm) command to clear the warning.

Note: Use Pn008 = n.□X□□ (Warning Detection Selection) to control warning detection.

However, the following warnings are not affected by the setting of Pn008 = n.□X□□ and other parameter settings are required in addition to Pn008 = n.□X□□.

Warning	Parameters That Must Be Set to Select Warning Detection
A.911	Pn310 = n.□□□X (Vibration Detection Setting)
A.923	– (Not affected by the setting of Pn008 = n.□X□□.)
A.930	Pn008 = n.□□□X (Low Battery Voltage Alarm/Warning Selection)
A.942	Pn423 = n.□□X□ (Speed Ripple Compensation Information Disagreement Warning Detection Selection)
A.94A to A.960 and A.97A to A.97b	Pn800=n.□□X□ (Warning Check Masks)
A.971	Pn008 = n.□□□X (Low Battery Voltage Alarm/Warning Selection) (Not affected by the setting of Pn008 = n.□X□□.)
A.9A0	Pn00D = n.X□□□ (Overtravel Warning Detection Selection) (Not affected by the setting of Pn008 = n.□X□□.)
A.9b0	Pn00F = n.□□□X (Preventative Maintenance Selection)

## 5.6 Troubleshooting Warnings

The causes of and corrections for the warnings are given in the following table. Contact your Yaskawa representative if you cannot solve a problem with the correction given in the table.

Warning Number: Warning Name	Possible Cause	Confirmation	Correction	Reference
A.900: Position Deviation Overflow	The Servomotor U, V, and W wiring is not correct.	Check the wiring of the Servomotor's Main Circuit Cables.	Make sure that there are no faulty connections in the wiring for the Servomotor and encoder.	–
	A SERVOPACK gain is too low.	Check the SERVO-PACK gains.	Increase the servo gain, e.g., by using autotuning without a host reference.	*
	The acceleration of the position reference is too high.	Reduce the reference acceleration and try operating the SERVO-PACK.	Reduce the acceleration of the position reference using a MECHATROLINK command. Or, smooth the position reference acceleration by selecting the position reference filter (ACCFIL) using a MECHATROLINK command.	–
	The excessive position deviation alarm level (Pn520 × Pn51E/100) is too low for the operating conditions.	Check excessive position deviation alarm level (Pn520 × Pn51E/100) to see if it is set to an appropriate value.	Optimize the settings of Pn520 and Pn51E.	*
	A failure occurred in the SERVO-PACK.	–	Turn the power supply to the SERVOPACK OFF and ON again. If an alarm still occurs, the SERVOPACK may be faulty. Replace the SERVOPACK.	–
A.901: Position Deviation Overflow Alarm at Servo ON	The position deviation when the servo was turned ON exceeded the percentage set with the following formula: (Pn526 × Pn528/100)	–	Optimize the setting of Pn528 (Excessive Position Error Warning Level at Servo ON).	–

Continued on next page.

Continued from previous page.

Warning Number: Warning Name	Possible Cause	Confirmation	Correction	Reference
A.910: Overload (warning before an A.710 or A.720 alarm occurs)	The wiring is not correct or there is a faulty contact in the motor or encoder wiring.	Check the wiring.	Make sure that the Servomotor and encoder are correctly wired.	–
	Operation was performed that exceeded the overload protection characteristics.	Check the motor overload characteristics and Run command.	Reconsider the load and operating conditions. Or, increase the motor capacity.	–
	An excessive load was applied during operation because the Servomotor was not driven because of mechanical problems.	Check the operation reference and motor speed.	Remove the mechanical problem.	–
	The overload warning level (Pn52B) is not suitable.	Check that the overload warning level (Pn52B) is suitable.	Set a suitable overload warning level (Pn52B).	*
	A failure occurred in the SERVOPACK.	–	The SERVOPACK may be faulty. Replace the SERVOPACK.	–
A.911: Vibration	Abnormal vibration was detected during motor operation.	Check for abnormal motor noise, and check the speed and torque waveforms during operation.	Reduce the motor speed. Or, reduce the servo gain with custom tuning.	*
	The setting of Pn103 (Moment of Inertia Ratio) is greater than the actual moment of inertia or was greatly changed.	Check the moment of inertia ratio or mass ratio.	Set Pn103 (Moment of Inertia Ratio) to an appropriate value.	*
	The vibration detection level (Pn312 or Pn384) is not suitable.	Check that the vibration detection level (Pn312 or Pn384) is suitable.	Set a suitable vibration detection level (Pn312 or Pn384).	*

Continued on next page.

Continued from previous page.

Warning Number: Warning Name	Possible Cause	Confirmation	Correction	Reference
<b>A.912:</b> Internal Temperature Warning 1 (Control Board Temperature Error)	The surrounding temperature is too high.	Check the surrounding temperature using a thermostat. Or, check the operating status with the SERVOPACK installation environment monitor.	Decrease the surrounding temperature by improving the SERVOPACK installation conditions.	*
	An overload alarm was reset by turning OFF the power supply too many times.	Check the alarm display to see if there is an overload alarm.	Change the method for resetting the alarm.	–
	There was an excessive load or operation was performed that exceeded the regenerative processing capacity.	Use the accumulated load ratio to check the load during operation, and use the regenerative load ratio to check the regenerative processing capacity.	Reconsider the load and operating conditions.	–
	The SERVOPACK installation orientation is not correct or there is insufficient space around the SERVOPACK.	Check the SERVOPACK installation conditions.	Install the SERVOPACK according to specifications.	*
	A failure occurred in the SERVOPACK.	–	The SERVOPACK may be faulty. Replace the SERVOPACK.	–
<b>A.913:</b> Internal Temperature Warning 2 (Power Board Temperature Error)	The surrounding temperature is too high.	Check the surrounding temperature using a thermostat. Or, check the operating status with the SERVOPACK installation environment monitor.	Decrease the surrounding temperature by improving the SERVOPACK installation conditions.	*
	An overload alarm was reset by turning OFF the power supply too many times.	Check the alarm display to see if there is an overload alarm.	Change the method for resetting the alarm.	–
	There was an excessive load or operation was performed that exceeded the regenerative processing capacity.	Use the accumulated load ratio to check the load during operation, and use the regenerative load ratio to check the regenerative processing capacity.	Reconsider the load and operating conditions.	–
	The SERVOPACK installation orientation is not correct or there is insufficient space around the SERVOPACK.	Check the SERVOPACK installation conditions.	Install the SERVOPACK according to specifications.	*
	A failure occurred in the SERVOPACK.	–	The SERVOPACK may be faulty. Replace the SERVOPACK.	–

Continued on next page.

Continued from previous page.

Warning Number: Warning Name	Possible Cause	Confirmation	Correction	Reference
A.920: Regenerative Overload (warning before an A.320 alarm occurs)	The power supply voltage exceeded the specified range.	Measure the power supply voltage.	Set the power supply voltage within the specified range.	–
	There is insufficient external regenerative resistance, regenerative resistor capacity, or SERVOPACK capacity, or there has been a continuous regeneration state.	Check the operating conditions or the capacity using the SigmaJunmaSize+ Capacity Selection Software or another means.	Change the regenerative resistance value, regenerative resistance capacity, or SERVOPACK capacity. Reconsider the operating conditions using the SigmaJunmaSize+ Capacity Selection Software or other means.	–
	There was a continuous regeneration state because a negative load was continuously applied.	Check the load applied to the Servomotor during operation.	Reconsider the system including the servo, machine, and operating conditions.	–
A.921: Dynamic Brake Overload (warning before an A.731 alarm occurs)	The Servomotor was rotated by an external force.	Check the operation status.	Implement measures to ensure that the motor will not be rotated by an external force.	–
	When the Servomotor was stopped with the dynamic brake, the rotational or linear kinetic energy exceeded the capacity of the dynamic brake resistor.	Check the power consumed by the DB resistor to see how frequently the DB is being used.	Reconsider the following: <ul style="list-style-type: none"> <li>• Reduce the Servomotor command speed.</li> <li>• Decrease the moment of inertia or mass.</li> <li>• Reduce the frequency of stopping with the dynamic brake.</li> </ul>	–
	A failure occurred in the SERVOPACK.	–	The SERVOPACK may be faulty. Replace the SERVOPACK.	–
A.923: SERVOPACK Built-in Fan Stopped	The fan inside the SERVOPACK stopped.	Check for foreign matter inside the SERVOPACK.	Remove foreign matter from the SERVOPACK. If an alarm still occurs, the SERVOPACK may be faulty. Replace the SERVOPACK.	–
A.930: Absolute Encoder Battery Error (The absolute encoder battery voltage was lower than the specified level.) (Detected only when an absolute encoder is connected.)	The battery connection is faulty or a battery is not connected.	Check the battery connection.	Correct the battery connection.	*
	The battery voltage is lower than the specified value (2.7 V).	Measure the battery voltage.	Replace the battery.	*
	A failure occurred in the SERVOPACK.	–	The SERVOPACK may be faulty. Replace the SERVOPACK.	–

Continued on next page.

Continued from previous page.

Warning Number: Warning Name	Possible Cause	Confirmation	Correction	Reference
<b>A.930:</b> Absolute Encoder Battery Error (The absolute encoder battery voltage was lower than the specified level.) (Detected only when an absolute encoder is connected.)	The battery connection is faulty or a battery is not connected.	Check the battery connection.	Correct the battery connection.	*
	The battery voltage is lower than the specified value (2.7 V).	Measure the battery voltage.	Replace the battery.	*
	A failure occurred in the SERVOPACK.	–	The SERVOPACK may be faulty. Replace the SERVOPACK.	–
<b>A.93B:</b> Overheat Warning	The surrounding temperature is too high.	Check the surrounding temperature using a thermostat.	Lower the surrounding temperature by improving the installation conditions of the machine.	–
	Operation was performed under an excessive load.	Use the accumulated load ratio to check the load during operation.	Reconsider the load and operating conditions.	–
	A failure occurred in the SERVOPACK.	–	The SERVOPACK may be faulty. Replace the SERVOPACK.	–
	The sensor attached to the machine is faulty.	–	The sensor attached to the machine may be faulty. Repair the sensor attached to the machine.	–
<b>A.942:</b> Speed Ripple Compensation Information Disagreement	The speed ripple compensation information stored in the encoder does not agree with the speed ripple compensation information stored in the SERVOPACK.	–	Reset the speed ripple compensation value on the SigmaWin+.	*
		–	Set Pn423 to n.□□1□ (Do not detect A.942 alarms). However, changing the setting may increase the speed ripple.	*
		–	Set Pn423 to n.□□□0 (Disable torque ripple compensation). However, changing the setting may increase the speed ripple.	*
<b>A.94A:</b> Data Setting Warning 1 (Parameter Number Error)	An invalid parameter number was used.	Check the command that caused the warning.	Use the correct parameter number.	*
<b>A.94b:</b> Data Setting Warning 2 (Out of Range)	The set command data was clamped to the minimum or maximum value of the setting range.	Check the command that caused the warning.	Set the parameter within the setting range.	*
<b>A.94C:</b> Data Setting Warning 3 (Calculation Error)	The calculation result of the setting is not correct.	Check the command that caused the warning.	Set the parameter within the setting range.	*
<b>A.94d:</b> Data Setting Warning 4 (Parameter Size)	The parameter size set in the command is not correct.	Check the command that caused the warning.	Set the correct parameter size.	*

Continued on next page.



Continued from previous page.

Warning Number: Warning Name	Possible Cause	Confirmation	Correction	Reference
<b>A.94E:</b> Data Setting Warning 5 (Latch Mode Error)	A latch mode error was detected.	Check the command that caused the warning.	Change the setting of Pn850 or the LT_MOD data for the LTMOD_ON command sent by the host controller to an appropriate value. (The applies when using the MECHATROLINK-II-compatible profile.)	*
<b>A.95A:</b> Command Warning 1 (Unsatisfied Command Conditions)	The command conditions are not satisfied.	Check the command that caused the warning.	Send the command after the command conditions are satisfied.	*
<b>A.95b:</b> Command Warning 2 (Unsupported Command)	An unsupported command was received.	Check the command that caused the warning.	Do not send unsupported commands.	*
<b>A.95d:</b> Command Warning 4 (Command Interference)	The command sending conditions for latch-related commands was not satisfied.	Check the command that caused the warning.	Send the command after the command conditions are satisfied.	*
<b>A.95E:</b> Command Warning 5 (Subcommand Not Possible)	The command sending conditions for subcommands was not satisfied.	Check the command that caused the warning.	Send the command after the conditions are satisfied.	*
<b>A.95F:</b> Command Warning 6 (Undefined Command)	An undefined command was sent.	Check the command that caused the warning.	Do not send undefined commands.	*
<b>A.960:</b> MECHATROLINK Communications Warning	The MECHATROLINK Communications Cable is not wired correctly.	Check the wiring conditions.	Correct the MECHATROLINK communications cable wiring.	*
	A MECHATROLINK data reception error occurred due to noise.	Confirm the installation conditions.	Implement the following countermeasures against noise. • Check the MECHATROLINK Communications Cable and FG wiring and implement countermeasures to prevent noise from entering. • Attach a ferrite core to the MECHATROLINK Communications Cable.	–
	A failure occurred in the SERVOPACK.	–	The SERVOPACK may be faulty. Replace the SERVOPACK.	–

Continued on next page.

Continued from previous page.

Warning Number: Warning Name	Possible Cause	Confirmation	Correction	Reference
A.971: Undervoltage	For a 200-V SERVOPACK, the AC power supply voltage dropped below 140 V.	Measure the power supply voltage.	Set the power supply voltage within the specified range.	–
	For a 100-V SERVOPACK, the AC power supply voltage dropped below 60 V.	Measure the power supply voltage.	Set the power supply voltage within the specified range.	–
	The power supply voltage dropped during operation.	Measure the power supply voltage.	Increase the power supply capacity.	–
	A momentary power interruption occurred.	Measure the power supply voltage.	If you have changed the setting of Pn509 (Momentary Power Interruption Hold Time), decrease the setting.	*
	The SERVOPACK fuse is blown out.	–	Replace the SERVOPACK and connect a reactor.	*
	A failure occurred in the SERVOPACK.	–	The SERVOPACK may be faulty. Replace the SERVOPACK.	–
A.97A: Command Warning 7 (Phase Error)	A command that cannot be executed in the current phase was sent.	–	Send the command after the command conditions are satisfied.	–
A.97b: Data Clamp Out of Range	The set command data was clamped to the minimum or maximum value of the setting range.	–	Set the command data within the setting ranges.	–
A.9A0: Overtravel (Overtravel status was detected.)	Overtravel was detected while the servo was ON.	Check the status of the overtravel signals on the input signal monitor.	Even if an overtravel signal is not shown by the input signal monitor, momentary overtravel may have been detected. Take the following precautions. <ul style="list-style-type: none"> <li>• Do not specify movements that would cause overtravel from the host controller.</li> <li>• Check the wiring of the overtravel signals.</li> <li>• Implement countermeasures against noise.</li> </ul>	*
A.9b0: Preventative Maintenance Warning	One of the consumable parts has reached the end of its service life.	–	Replace the part. Contact your Yaskawa representative for replacement.	*

\* Refer to the following manual for details.

  $\Sigma$ -7-Series  $\Sigma$ -7S SERVOPACK with MECHATROLINK-III Communications References Product Manual (Manual No.: SIEP S800001 28)

  $\Sigma$ -7-Series  $\Sigma$ -7S SERVOPACK with MECHATROLINK-III Communications References and RJ-45 Connectors Product Manual (Manual No.: SIEP S800001 62)

## 5.7

## Troubleshooting Based on the Operation and Conditions of the Servomotor

This section provides troubleshooting based on the operation and conditions of the Servomotor, including causes and corrections.

Problem	Possible Cause	Confirmation	Correction	Reference
Servomotor Does Not Start	The control power supply is not turned ON.	Measure the voltage between control power supply terminals.	Turn OFF the power supply to the servo system. Correct the wiring so that the control power supply is turned ON.	-
	The main circuit power supply is not turned ON.	Measure the voltage across the main circuit power input terminals.	Turn OFF the power supply to the servo system. Correct the wiring so that the main circuit power supply is turned ON.	-
	The I/O signal connector (CN1) pins are not wired correctly or are disconnected.	Turn OFF the power supply to the servo system. Check the wiring condition of the I/O signal connector (CN1) pins.	Correct the wiring of the I/O signal connector (CN1) pins.	*
	The wiring for the Servomotor Main Circuit Cables or Encoder Cable is disconnected.	Check the wiring conditions.	Turn OFF the power supply to the servo system. Wire the cable correctly.	-
	There is an overload on the Servomotor.	Operate the Servomotor with no load and check the load status.	Turn OFF the power supply to the servo system. Reduce the load or replace the Servomotor with a Servomotor with a larger capacity.	-
	The type of encoder that is being used does not agree with the setting of Pn002 = n.□X□□ (Encoder Usage).	Check the type of the encoder that is being used and the setting of Pn002 = n.□X□□.	Set Pn002 = n.□X□□ according to the type of the encoder that is being used.	*
	There is a mistake in the input signal allocations (Pn50A, Pn50B, Pn511, and Pn516).	Check the input signal allocations (Pn50A, Pn50B, Pn511, and Pn516).	Correctly allocate the input signals (Pn50A, Pn50B, Pn511, and Pn516).	*
	The SV_ON command was not sent.	Check the commands sent from the host controller.	Send the SV_ON command from the host controller.	-
	The SENS_ON (Turn ON Sensor) command was not sent.	Check the commands sent from the host controller.	Send the commands to the SERVOPACK in the correct sequence.	-
	The P-OT (Forward Drive Prohibit) or N-OT (Reverse Drive Prohibit) signal is still OFF.	Check the P-OT and N-OT signals.	Turn ON the P-OT and N-OT signals.	*
The safety input signals (/HWBB1 or /HWBB2) were not turned ON.	Check the /HWBB1 and /HWBB2 input signals.	Turn ON the /HWBB1 and /HWBB2 input signals. If you are not using the safety function, connect the Safety Jumper Connector (provided as an accessory) to CN8.	*	

Continued on next page.

Continued from previous page.

Problem	Possible Cause	Confirmation	Correction	Reference
Servomotor Does Not Start	The FSTP (Forced Stop Input) signal is still OFF.	Check the FSTP signal.	<ul style="list-style-type: none"> <li>• Turn ON the FSTP signal.</li> <li>• If you will not use the function to force the motor to stop, set Pn516 = n.□□□X (FSTP (Forced Stop Input) Signal Allocation) to disable the signal.</li> </ul>	*
	A failure occurred in the SERVOPACK.	–	Turn OFF the power supply to the servo system. Replace the SERVOPACK.	–
Servomotor Moves Instantaneously, and Then Stops	There is a mistake in the Servomotor wiring.	Turn OFF the power supply to the servo system. Check the wiring.	Wire the Servomotor correctly.	–
	There is a mistake in the wiring of the encoder or Serial Converter Unit.	Turn OFF the power supply to the servo system. Check the wiring.	Wire the Serial Converter Unit correctly.	–
Servomotor Speed Is Unstable	There is a faulty connection in the Servomotor wiring.	Turn OFF the power supply to the servo system. The connector connections for the power line (U, V, and W phases) and the encoder or Serial Converter Unit may be unstable. Check the wiring.	Tighten any loose terminals or connectors and correct the wiring.	–
Servomotor Moves without a Reference Input	A failure occurred in the SERVOPACK.	–	Turn OFF the power supply to the servo system. Replace the SERVOPACK.	–
Dynamic Brake Does Not Operate	The setting of Pn001 = n.□□□X (Servo OFF or Alarm Group 1 Stopping Method) is not suitable.	Check the setting of Pn001 = n.□□□X.	Set Pn001 = n.□□□X correctly.	–
	The dynamic brake resistor is disconnected.	Check the moment of inertia, motor speed, and dynamic brake frequency of use. If the moment of inertia, motor speed, or dynamic brake frequency of use is excessive, the dynamic brake resistance may be disconnected.	Turn OFF the power supply to the servo system. Replace the SERVOPACK. To prevent disconnection, reduce the load.	–
	There was a failure in the dynamic brake drive circuit.	–	Turn OFF the power supply to the servo system. There is a defective component in the dynamic brake circuit. Replace the SERVOPACK.	–

Continued on next page.

Continued from previous page.

Problem	Possible Cause	Confirmation	Correction	Reference
Abnormal Noise from Servomotor	The Servomotor vibrated considerably while performing the tuning-less function with the default settings.	Check the waveform of the motor speed.	Reduce the load so that the moment of inertia ratio or mass ratio is within the allowable value, or increase the load level or reduce the rigidity level in the tuning-less level settings.	*
	The machine mounting is not secure.	Turn OFF the power supply to the servo system. Check to see if there are any loose mounting screws.	Tighten the mounting screws.	-
	The machine mounting is not secure.	Turn OFF the power supply to the servo system. Check to see if there is misalignment in the coupling.	Align the coupling.	-
		Turn OFF the power supply to the servo system. Check to see if the coupling is balanced.	Balance the coupling.	-
	The bearings are defective.	Turn OFF the power supply to the servo system. Check for noise and vibration around the bearings.	Replace the Servomotor.	-
	There is a vibration source at the driven machine.	Turn OFF the power supply to the servo system. Check for any foreign matter, damage, or deformation in the machine's moving parts.	Consult with the machine manufacturer.	-
	Noise interference occurred because of incorrect I/O signal cable specifications.	Turn OFF the power supply to the servo system. Check the I/O signal cables to see if they satisfy specifications. Use shielded twisted-pair wire cables or screened twisted-pair cables with conductors of at least 0.12 mm <sup>2</sup> .	Use cables that satisfy the specifications.	-
	Noise interference occurred because an I/O signal cable is too long.	Turn OFF the power supply to the servo system. Check the lengths of the I/O signal cables.	The I/O signal cables must be no longer than 3 m.	-
	Noise interference occurred because of incorrect Encoder Cable specifications.	Turn OFF the power supply to the servo system. Make sure that the rotary Encoder Cable satisfies the specifications. Use a shielded twisted-pair wire cable or a screened twisted-pair cable with a conductors of at least 0.12 mm <sup>2</sup> .	Use cables that satisfy the specifications.	-
Noise interference occurred because the Encoder Cable is too long.	Turn OFF the power supply to the servo system. Check the length of the Encoder Cable.	The Encoder Cable length must be 50 m max.	-	

Continued on next page.

Continued from previous page.

Problem	Possible Cause	Confirmation	Correction	Reference
Abnormal Noise from Servomotor	Noise interference occurred because the Encoder Cable is damaged.	Turn OFF the power supply to the servo system. Check the Encoder Cable to see if it is pinched or the sheath is damaged.	Replace the Encoder Cable and correct the cable installation environment.	-
	The Encoder Cable was subjected to excessive noise interference.	Turn OFF the power supply to the servo system. Check to see if the Encoder Cable is bundled with a high-current line or installed near a high-current line.	Correct the cable layout so that no surge is applied by high-current lines.	-
	There is variation in the FG potential because of the influence of machines on the Servomotor side, such as a welder.	Turn OFF the power supply to the servo system. Check to see if the machines are correctly grounded.	Properly ground the machines to separate them from the FG of the encoder.	-
	There is a SERVOPACK pulse counting error due to noise.	Check to see if there is noise interference on the signal line from the encoder.	Turn OFF the power supply to the servo system. Implement countermeasures against noise for the encoder wiring.	-
	The encoder was subjected to excessive vibration or shock.	Turn OFF the power supply to the servo system. Check to see if vibration from the machine occurred. Check the Servomotor installation (mounting surface precision, securing state, and alignment).	Reduce machine vibration. Improve the mounting conditions of the Servomotor.	-
	A failure occurred in the encoder.	-	Turn OFF the power supply to the servo system. Replace the Servomotor.	-
Servomotor Vibrates at Frequency of Approx. 200 to 400 Hz.	The servo gains are not balanced.	Check to see if the servo gains have been correctly tuned.	Perform autotuning without a host reference.	*
	The setting of Pn100 (Speed Loop Gain) is too high.	Check the setting of Pn100. The default setting is Kv = 40.0 Hz.	Set Pn100 to an appropriate value.	-
	The setting of Pn102 (Position Loop Gain) is too high.	Check the setting of Pn102. The default setting is Kp = 40.0/s.	Set Pn102 to an appropriate value.	-
	The setting of Pn101 (Speed Loop Integral Time Constant) is not appropriate.	Check the setting of Pn101. The default setting is Ti = 20.0 ms.	Set Pn101 to an appropriate value.	-
	The setting of Pn103 (Moment of Inertia Ratio or Mass Ratio) is not appropriate.	Check the setting of Pn103.	Set Pn103 to an appropriate value.	-

Continued on next page.

Continued from previous page.

Problem	Possible Cause	Confirmation	Correction	Reference
Large Motor Speed Overshoot on Starting and Stopping	The servo gains are not balanced.	Check to see if the servo gains have been correctly tuned.	Perform autotuning without a host reference.	*
	The setting of Pn100 (Speed Loop Gain) is too high.	Check the setting of Pn100. The default setting is Kv = 40.0 Hz.	Set Pn100 to an appropriate value.	-
	The setting of Pn102 (Position Loop Gain) is too high.	Check the setting of Pn102. The default setting is Kp = 40.0/s.	Set Pn102 to an appropriate value.	-
	The setting of Pn101 (Speed Loop Integral Time Constant) is not appropriate.	Check the setting of Pn101. The default setting is Ti = 20.0 ms.	Set Pn101 to an appropriate value.	-
	The setting of Pn103 (Moment of Inertia Ratio or Mass Ratio) is not appropriate.	Check the setting of Pn103.	Set Pn103 to an appropriate value.	-
	The torque reference is saturated.	Check the waveform of the torque reference.	Use the mode switch.	-
	The force limits (Pn483 and Pn484) are set to the default values.	The default values of the force limits and Pn483 = 30% and Pn484 = 30%.	Set Pn483 and Pn484 to appropriate values.	*
Absolute Encoder Position Deviation Error (The position that was saved in the host controller when the power was turned OFF is different from the position when the power was next turned ON.)	Noise interference occurred because of incorrect Encoder Cable specifications.	Turn OFF the power supply to the servo system. Check the Encoder Cable to see if it satisfies specifications. Use a shielded twisted-pair wire cable or a screened twisted-pair cable with conductors of at least 0.12 mm <sup>2</sup> .	Use cables that satisfy the specifications.	-
	Noise interference occurred because the Encoder Cable is too long.	Turn OFF the power supply to the servo system. Check the length of the Encoder Cable.	The Encoder Cable length must be 50 m max.	-
	Noise interference occurred because the Encoder Cable is damaged.	Turn OFF the power supply to the servo system. Check the Encoder Cable to see if it is pinched or the sheath is damaged.	Replace the Encoder Cable and correct the cable installation environment.	-
	Replace the Encoder Cable and correct the cable installation environment.	Turn OFF the power supply to the servo system. Check to see if the Encoder Cable is bundled with a high-current line or installed near a high-current line.	Correct the cable layout so that no surge is applied by high-current lines.	-
	There is variation in the FG potential because of the influence of machines on the Servomotor side, such as a welder.	Turn OFF the power supply to the servo system. Check to see if the machines are correctly grounded.	Properly ground the machines to separate them from the FG of the encoder.	-
	There is a SERVOPACK pulse counting error due to noise.	Turn OFF the power supply to the servo system. Check to see if there is noise interference on the I/O signal line from the encoder or Serial Converter Unit.	Implement countermeasures against noise for the encoder or Serial Converter Unit wiring.	-

Continued on next page.

Continued from previous page.

Problem	Possible Cause	Confirmation	Correction	Reference	
Absolute Encoder Position Deviation Error (The position that was saved in the host controller when the power was turned OFF is different from the position when the power was next turned ON.)	The encoder was subjected to excessive vibration or shock.	Turn OFF the power supply to the servo system. Check to see if vibration from the machine occurred. Check the Servomotor installation (mounting surface precision, securing state, and alignment).	Reduce machine vibration. Or, improve the mounting conditions of the Servomotor.	-	
	A failure occurred in the encoder.	-	Turn OFF the power supply to the servo system. Replace the Servomotor.	-	
	A failure occurred in the SERVOPACK.	-	Turn OFF the power supply to the servo system. Replace the SERVOPACK.	-	
	Host Controller Multiturn Data or Absolute Encoder Position Data Reading Error	Check the error detection section of the host controller.	Check the error detection section of the host controller.	Correct the error detection section of the host controller.	-
		Check to see if the host controller is executing data parity checks.	Check to see if the host controller is executing data parity checks.	Perform parity checks for the multiturn data or absolute encoder position data.	-
		Check for noise interference in the cable between the SERVOPACK and the host controller.	Check for noise interference in the cable between the SERVOPACK and the host controller.	Implement countermeasures against noise and then perform parity checks again for the multiturn data or absolute encoder position data.	-
	Overtravel Occurred	The P-OT/N-OT (Forward Drive Prohibit or Reverse Drive Prohibit) signal was input.	Check the external power supply (+24 V) voltage for the input signals.	Correct the external power supply (+24 V) voltage for the input signals.	-
Check the operating condition of the overtravel limit switches.			Make sure that the overtravel limit switches operate correctly.	-	
Check the wiring of the overtravel limit switches.			Correct the wiring of the overtravel limit switches.	*	
Check the settings of the overtravel input signal allocations (Pn50A/Pn50B).			Set the parameters to correct values.	*	
The P-OT/N-OT (Forward Drive Prohibit or Reverse Drive Prohibit) signal malfunctioned.		Check for fluctuation in the external power supply (+24 V) voltage for the input signals.	Check for fluctuation in the external power supply (+24 V) voltage for the input signals.	Eliminate fluctuation from the external power supply (+24 V) voltage for the input signals.	-
		Check to see if the operation of the overtravel limit switches is unstable.	Check to see if the operation of the overtravel limit switches is unstable.	Stabilize the operating condition of the overtravel limit switches.	-
		Check the wiring of the overtravel limit switches (e.g., check for cable damage and loose screws).	Check the wiring of the overtravel limit switches (e.g., check for cable damage and loose screws).	Correct the wiring of the overtravel limit switches.	-

Continued on next page.



Continued from previous page.

Problem	Possible Cause	Confirmation	Correction	Reference
Overtravel Occurred	There is a mistake in the allocation of the P-OT or N-OT (Forward Drive Prohibit or Reverse Drive Prohibit) signal in Pn50A = n.X□□□ or Pn50B = n.□□□X.	Check to see if the P-OT signal is allocated in Pn50A = n.X□□□.	If another signal is allocated in Pn50A =n.X□□□, allocate the P-OT signal instead.	*
		Check to see if the N-OT signal is allocated in Pn50B = n.□□□X.	If another signal is allocated in Pn50B =n.□□□X, allocate the N-OT signal instead.	*
	The selection of the Servomotor stopping method is not correct.	Check the servo OFF stopping method set in Pn001 = n.□□□X or Pn001 = n.□□X□.	Select a Servomotor stopping method other than coasting to a stop.	*
		Check the torque control stopping method set in Pn001 = n.□□□X or Pn001 = n.□□X□.	Select a Servomotor stopping method other than coasting to a stop.	*
Improper Stop Position for Overtravel (OT) Signal	The limit switch position and dog length are not appropriate.	-	Install the limit switch at the appropriate position.	-
	The overtravel limit switch position is too close for the coasting distance.	-	Install the overtravel limit switch at the appropriate position.	-
Position Deviation (without Alarm)	Noise interference occurred because of incorrect Encoder Cable specifications.	Turn OFF the power supply to the servo system. Check the Encoder Cable to see if it satisfies specifications. Use a shielded twisted-pair wire cable or a screened twisted-pair cable with conductors of at least 0.12 mm <sup>2</sup> .	Use cables that satisfy the specifications.	-
	Noise interference occurred because the Encoder Cable is too long.	Turn OFF the power supply to the servo system. Check the length of the Encoder Cable.	The Encoder Cable length must be 50 m max.	-
	Noise interference occurred because the Encoder Cable is damaged.	Turn OFF the power supply to the servo system. Check the Encoder Cable to see if it is pinched or the sheath is damaged.	Replace the Encoder Cable and correct the cable installation environment.	-
	The Encoder Cable was subjected to excessive noise interference.	Turn OFF the power supply to the servo system. Check to see if the Encoder Cable is bundled with a high-current line or installed near a high-current line.	Correct the cable layout so that no surge is applied by high-current lines.	-
	There is variation in the FG potential because of the influence of machines on the Servomotor side, such as a welder.	Turn OFF the power supply to the servo system. Check to see if the machines are correctly grounded.	Properly ground the machines to separate them from the FG of the encoder.	-
	There is a SERVOPACK pulse counting error due to noise.	Turn OFF the power supply to the servo system. Check to see if there is noise interference on the I/O signal line from the encoder or Serial Converter Unit.	Implement countermeasures against noise for the encoder wiring or Serial Converter Unit wiring.	-

Continued on next page.

Continued from previous page.

Problem	Possible Cause	Confirmation	Correction	Reference
Position Deviation (without Alarm)	The encoder was subjected to excessive vibration or shock.	Turn OFF the power supply to the servo system. Check to see if vibration from the machine occurred. Check the Servomotor installation (mounting surface precision, securing state, and alignment).	Reduce machine vibration. Or, improve the mounting conditions of the Servomotor.	–
	The coupling between the machine and Servomotor is not suitable.	Turn OFF the power supply to the servo system. Check to see if position offset occurs at the coupling between machine and Servomotor.	Correctly secure the coupling between the machine and Servomotor.	–
	Noise interference occurred because of incorrect I/O signal cable specifications.	Turn OFF the power supply to the servo system. Check the I/O signal cables to see if they satisfy specifications. Use a shielded twisted-pair wire cable or a screened twisted-pair cable with conductors of at least 0.12 mm <sup>2</sup> .	Use cables that satisfy the specifications.	–
	Noise interference occurred because an I/O signal cable is too long.	Turn OFF the power supply to the servo system. Check the lengths of the I/O signal cables.	The I/O signal cables must be no longer than 3 m.	–
	An encoder fault occurred. (The pulse count does not change.)	–	Turn OFF the power supply to the servo system. Replace the Servomotor.	–
	A failure occurred in the SERVOPACK.	–	Turn OFF the power supply to the servo system. Replace the SERVOPACK.	–
Servomotor Overheated	The surrounding air temperature is too high.	Measure the surrounding air temperature around the Servomotor.	Reduce the surrounding air temperature to 40°C or less.	–
	The surface of the Servomotor is dirty.	Turn OFF the power supply to the servo system. Visually check the surface for dirt.	Clean dirt, dust, and oil from the surface.	–
	There is an overload on the Servomotor.	Check the load status with a monitor.	If the Servomotor is overloaded, reduce the load or replace the Servo Drive with a SERVOPACK and Servomotor with larger capacities.	–
	Polarity detection was not performed correctly.	Check to see if electrical angle 2 (electrical angle from polarity origin) at any position is between ±10°.	Correct the settings for the polarity detection-related parameters.	–
Estimating the moment of inertia failed.	The acceleration rate is low and travel distance is short.	Check the Condition Setting Dialog Box used to perform moment of inertia estimation.	Increase the acceleration rate and travel distance.	–

\* Refer to the following manual for details.

  $\Sigma$ -7-Series  $\Sigma$ -7S SERVOPACK with MECHATROLINK-III Communications References Product Manual (Manual No.: SIEP S800001 28)

  $\Sigma$ -7-Series  $\Sigma$ -7S SERVOPACK with MECHATROLINK-III Communications References and RJ-45 Connectors Product Manual (Manual No.: SIEP S800001 62)

# Parameter Lists

---



This chapter provides information on the parameters.

<b>6.1</b>	<b>Interpreting the Parameter Lists . . . . .</b>	<b>6-2</b>
6.1.1	Interpreting the Servo Parameter List . . . . .	6-2
6.1.2	Interpreting the MECHATROLINK-III Common Parameter List . . . . .	6-2
<b>6.2</b>	<b>List of Servo Parameters . . . . .</b>	<b>6-3</b>
<b>6.3</b>	<b>List of MECHATROLINK-III Common Parameters . .</b>	<b>6-40</b>

# 6.1 Interpreting the Parameter Lists

## 6.1.1 Interpreting the Servo Parameter List

"After restart" indicates parameters that will be effective after one of the following is executed.

- The power supply is turned OFF and ON again.
- The Setup Device command (CONFIG) is sent.
- A software reset is executed.

Parameter No.	Size	Name	Setting Range	Setting Unit	Default Setting	Applicable Motors	When Enabled	Classification	Reference
Pn000	2	Basic Function Selections 0	0000h to 10B1h	-	0000h	Rotary	After restart	Setup	-
	<p>There are the following two classifications.</p> <ul style="list-style-type: none"> <li>• Setup</li> <li>• Tuning</li> </ul> <p>Refer to the following manual for details.</p> <ul style="list-style-type: none"> <li>Σ-7-Series Σ-7S SERVOPACK with MECHATROLINK-III Communications References Product Manual (Manual No.: SIEP S800001 28)</li> <li>Σ-7-Series Σ-7S SERVOPACK with MECHATROLINK-III Communications References and RJ-45 Connectors Product Manual (Manual No.: SIEP S800001 62)</li> </ul>								
	Rotation Direction Selection			Reference					
	n.□□□X	0	Use CCW as the forward direction.						-
		1	Use CW as the forward direction. (Reverse Rotation Mode)						
	n.□□□□	Reserved parameter (Do not change)							
	<p>Symbols are provided when a parameter is valid only for a specific profile.</p> <ul style="list-style-type: none"> <li>• <b>M2</b> Parameters that are valid only for a MECHATROLINK-II-compatible profile.</li> <li>• <b>M3</b> Parameters that are valid only for a MECHATROLINK-III standard servo profile.</li> </ul>								
	Start When Encoder Is Not Connected			Reference					
	n.X□□□	0	When an encoder is not connected, start as SERVOPACK for Rotary Servomotor.						-
		1	When an encoder is not connected, start as SERVOPACK for Linear Servomotor.						

## 6.1.2 Interpreting the MECHATROLINK-III Common Parameter List

Indicates when a change to the parameter will be effective. "After restart" indicates parameters that will be effective after one of the following is executed.

- The power supply is turned OFF and ON again.
- The Setup Device command (CONFIG) is sent.
- A software reset is executed.

Parameter No.	Size	Name	Setting Range	Setting Unit [Resolution]	Default Setting	Applicable Motors	When Enabled	Classification
61 PnAC2	4	Speed Loop Gain	1,000 to 2,000,000	0.001 Hz [0.1 Hz]	40000	Rotary	Immediately	Tuning

You can set the parameter in increments of the setting unit. However, if a unit is given in square brackets, the setting is automatically converted to the resolution given in the square brackets.

## 6.2 List of Servo Parameters

The following table lists the parameters.

Note: Do not change the following parameters from their default settings.

- Reserved parameters
- Parameters not given in this manual
- Parameters that are not valid for the Servomotor that you are using, as given in the parameter table

Parameter No.	Size	Name	Setting Range	Setting Unit	Default Setting	Applicable Motors	When Enabled	Classification	Reference	
Pn000	2	Basic Function Selections 0	0000h to 10B1h	–	0000h	Rotary	After restart	Setup	*1	
	n.□□□X		<b>Rotation Direction Selection</b>							
			0	Use CCW as the forward direction.						
			1	Use CW as the forward direction. (Reverse Rotation Mode)						
	n.□□X□		Reserved parameter (Do not change.)							
	n.□X□□		Reserved parameter (Do not change.)							
	n.X□□□		<b>Rotary/Linear Servomotor Startup Selection When Encoder Is Not Connected</b>							
			0	When an encoder is not connected, start as SERVOPACK for Rotary Servomotor.						
			1	When an encoder is not connected, start as SERVOPACK for Linear Servomotor.						
	Pn001	2	Application Function Selections 1	0000h to 1142h	–	0000h	Rotary	After restart	Setup	*1
n.□□□X		<b>Motor Stopping Method for Servo OFF and Group 1 Alarms</b>								
		0	Stop the motor by applying the dynamic brake.							
		1	Stop the motor by the applying dynamic brake and then release the dynamic brake.							
		2	Coast the motor to a stop without the dynamic brake.							
n.□□X□		<b>Overtravel Stopping Method</b>								
		0	Apply the dynamic brake or coast the motor to a stop (use the stopping method set in Pn001 = n.□□□X).							
		1	Decelerate the motor to a stop using the torque set in Pn406 as the maximum torque and then servo-lock the motor.							
		2	Decelerate the motor to a stop using the torque set in Pn406 as the maximum torque and then let the motor coast.							
		3	Decelerate the motor to a stop using the deceleration time set in Pn30A and then servo-lock the motor.							
		4	Decelerate the motor to a stop using the deceleration time set in Pn30A and then let the motor coast.							
n.□X□□		<b>Main Circuit Power Supply AC/DC Input Selection</b>								
		0	Input AC power as the main circuit power supply using the L1, L2, and L3 terminals (do not use shared converter).							
		1	Input DC power as the main circuit power supply using the B1/⊕ and ⊖ 2 terminals or the B1 and ⊖ 2 terminals (use an external converter or the shared converter).							
n.X□□□		Reserved parameter (Do not change.)								

Continued on next page.

Continued from previous page.

Parameter No.	Size	Name	Setting Range	Setting Unit	Default Setting	Applicable Motors	When Enabled	Classification	Reference	
Pn002	2	Application Function Selections 2	0000h to 4213h	-	0011h	Rotary	After restart	Setup	-	
	n.□□□X	<b>MECHATROLINK Command Position and Speed Control Option</b>							<b>Reference</b>	
		0	Reserved setting (Do not use.)							*2
		1	Use TLIM as the torque limit.							
		2	Reserved setting (Do not use.)							
	3	Reserved setting (Do not use.)								
	n.□□X□	<b>Torque Control Option</b>							<b>Reference</b>	
		0	Reserved setting (Do not use.)							*2
	1	Use the speed limit for torque control (VLIM) as the speed limit.								
	n.□X□□	<b>Encoder Usage</b>							<b>Reference</b>	
		0	Use the encoder according to encoder specifications.							*1
		1	Use the encoder as an incremental encoder.							
	2	Use the encoder as a single-turn absolute encoder.								
	n.X□□□	<b>External Encoder Usage</b>							<b>Reference</b>	
		0	Do not use an external encoder.							*1
		1	The external encoder moves in the forward direction for CCW motor rotation.							
		2	Reserved setting (Do not use.)							
3		The external encoder moves in the reverse direction for CCW motor rotation.								
4	Reserved setting (Do not use.)									
Pn006	2	Application Function Selections 6	0000h to 105Fh	-	0002h	Rotary	Immediately	Setup	*1	
	n.□□XX	<b>Analog Monitor 1 Signal Selection</b>								
		00	Motor speed (1 V/1,000 min <sup>-1</sup> )							
		01	Speed reference (1 V/1,000 min <sup>-1</sup> )							
		02	Torque reference (1 V/100% rated torque)							
		03	Position deviation (0.05 V/reference unit)							
		04	Position amplifier deviation (after electronic gear) (0.05 V/encoder pulse unit)							
		05	Position reference speed (1 V/1,000 min <sup>-1</sup> )							
		06	Reserved setting (Do not use.)							
		07	Load-motor position deviation (0.01 V/reference unit)							
		08	Positioning completion (positioning completed: 5 V, positioning not completed: 0 V)							
		09	Speed feedforward (1 V/1,000 min <sup>-1</sup> )							
		0A	Torque feedforward (1 V/100% rated torque)							
		0B	Active gain (1st gain: 1 V, 2nd gain: 2 V)							
		0C	Completion of position reference distribution (completed: 5 V, not completed: 0 V)							
		0D	External encoder speed (1 V/1,000 min <sup>-1</sup> : value at the motor shaft)							
	0E	Reserved setting (Do not use.)								
	0F	Reserved setting (Do not use.)								
	10	Main circuit DC voltage								
	11 to 5F	Reserved settings (Do not use.)								
n.□X□□	Reserved parameter (Do not change.)									
n.X□□□	Reserved parameter (Do not change.)									

Continued on next page.

Continued from previous page.

Parameter No.	Size	Name	Setting Range	Setting Unit	Default Setting	Applicable Motors	When Enabled	Classification	Reference	
Pn007	2	Application Function Selections 7	0000h to 105Fh	–	0000h	Rotary	Immediately	Setup	*1	
	n.□□XX	<b>Analog Monitor 2 Signal Selection</b>		00	Motor speed (1 V/1,000 min <sup>-1</sup> )					
		01	Speed reference (1 V/1,000 min <sup>-1</sup> )							
		02	Torque reference (1 V/100% rated torque)							
		03	Position deviation (0.05 V/reference unit)							
		04	Position amplifier deviation (after electronic gear) (0.05 V/encoder pulse unit)							
		05	Position reference speed (1 V/1,000 min <sup>-1</sup> )							
		06	Reserved setting (Do not use.)							
		07	Load-motor position deviation (0.01 V/reference unit)							
		08	Positioning completion (positioning completed: 5 V, positioning not completed: 0 V)							
		09	Speed feedforward (1 V/1,000 min <sup>-1</sup> )							
		0A	Torque feedforward (1 V/100% rated torque)							
		0B	Active gain (1st gain: 1 V, 2nd gain: 2 V)							
		0C	Completion of position reference distribution (completed: 5 V, not completed: 0 V)							
		0D	External encoder speed (1 V/1,000 min <sup>-1</sup> : value at the motor shaft)							
		0E	Reserved setting (Do not use.)							
		0F	Reserved setting (Do not use.)							
		10	Main circuit DC voltage							
	11 to 5F	Reserved settings (Do not use.)								
	n.□X□□	Reserved parameter (Do not change.)								
	n.X□□□	Reserved parameter (Do not change.)								
	Pn008	2	Application Function Selections 8	0000h to 7121h	–	4000h	Rotary	After restart	Setup	*1
		n.□□□X	<b>Low Battery Voltage Alarm/Warning Selection</b>		0	Output alarm (A.830) for low battery voltage.				
1			Output warning (A.930) for low battery voltage.							
n.□□X□		<b>Function Selection for Undervoltage</b>		0	Do not detect undervoltage.					
		1	Detect undervoltage warning and limit torque at host controller.							
		2	Detect undervoltage warning and limit torque with Pn424 and Pn425 (i.e., only in SERVOPACK).							
n.□X□□		<b>Warning Detection Selection</b>		0	Detect warnings.					
		1	Do not detect warnings except for A.971.							
n.X□□□		Reserved parameter (Do not change.)								

Continued on next page.

Continued from previous page.

Parameter No.	Size	Name	Setting Range	Setting Unit	Default Setting	Applicable Motors	When Enabled	Classification	Reference	
Pn009	2	Application Function Selections 9	0000h to 0121h	-	0010h	Rotary	After restart	Tuning	*1	
	n.□□□X		Reserved parameter (Do not change.)							
	n.□□□□		<b>Current Control Mode Selection</b>							
			0	Use current control mode 1.						
			1	<ul style="list-style-type: none"> <li>• SERVOPACK Models SGD7S-2R8A and -2R8F: Use current control mode 1.</li> <li>• SERVOPACK Model: SGD7S-120A: Use current control mode 2.</li> </ul>						
			2	Use current control mode 2.						
	n.□X□□		<b>Speed Detection Method Selection</b>							
			0	Use speed detection 1.						
			1	Use speed detection 2.						
	n.X□□□		Reserved parameter (Do not change.)							
Pn00A	2	Application Function Selections A	0000h to 0044h	-	0001h	Rotary	After restart	Setup	*1	
	n.□□□X		<b>Motor Stopping Method for Group 2 Alarms</b>							
			0	Apply the dynamic brake or coast the motor to a stop (use the stopping method set in Pn001 = n.□□□X).						
			1	Decelerate the motor to a stop using the torque set in Pn406 as the maximum torque. Use the setting of Pn001 = n.□□□X for the status after stopping.						
			2	Decelerate the motor to a stop using the torque set in Pn406 as the maximum torque and then let the motor coast.						
			3	Decelerate the motor to a stop using the deceleration time set in Pn30A. Use the setting of Pn001 = n.□□□X for the status after stopping.						
			4	Decelerate the motor to a stop using the deceleration time set in Pn30A and then let the motor coast.						
	n.□□□□		<b>Stopping Method for Forced Stops</b>							
			0	Apply the dynamic brake or coast the motor to a stop (use the stopping method set in Pn001 = n.□□□X).						
			1	Decelerate the motor to a stop using the torque set in Pn406 as the maximum torque. Use the setting of Pn001 = n.□□□X for the status after stopping.						
		2	Decelerate the motor to a stop using the torque set in Pn406 as the maximum torque and then let the motor coast.							
		3	Decelerate the motor to a stop using the deceleration time set in Pn30A. Use the setting of Pn001 = n.□□□X for the status after stopping.							
		4	Decelerate the motor to a stop using the deceleration time set in Pn30A and then let the motor coast.							
n.□X□□		Reserved parameter (Do not change.)								
n.X□□□		Reserved parameter (Do not change.)								

Continued on next page.



Continued from previous page.

Parameter No.	Size	Name	Setting Range	Setting Unit	Default Setting	Applicable Motors	When Enabled	Classification	Reference	
Pn00B	2	Application Function Selections B	0000h to 1121h	-	0000h	Rotary	After restart	Setup	*1	
	n.□□□X		<b>Operator Parameter Display Selection</b>							
			0	Display only setup parameters.						
			1	Display all parameters.						
	n.□□□□		<b>Motor Stopping Method for Group 2 Alarms</b>							
			0	Stop the motor by setting the speed reference to 0.						
			1	Apply the dynamic brake or coast the motor to a stop (use the stopping method set in Pn001 = n.□□□X).						
			2	Set the stopping method with Pn00A = n.□□□X.						
	n.□X□□		<b>Power Input Selection for Three-phase SERVOPACK</b>							
			0	Use a three-phase power supply input.						
		1	Use a three-phase power supply input as a single-phase power supply input.							
n.X□□□		Reserved parameter (Do not change.)								
Pn00C	2	Application Function Selections C	0000h to 0131h	-	0000h	Rotary	After restart	Setup	*1	
	n.□□□X		<b>Function Selection for Test without a Motor</b>							
			0	Disable tests without a motor.						
			1	Enable tests without a motor.						
	n.□□X□		<b>Encoder Resolution for Tests without a Motor</b>							
			0	Use 13 bits.						
			1	Use 20 bits.						
			2	Use 22 bits.						
			3	Use 24 bits.						
	n.□X□□		<b>Encoder Type Selection for Tests without a Motor</b>							
		0	Use an incremental encoder.							
		1	Use an absolute encoder.							
n.X□□□		Reserved parameter (Do not change.)								
Pn00D	2	Application Function Selections D	0000h to 1001h	-	0000h	Rotary	After restart	Setup	*1	
	n.□□□X		Reserved parameter (Do not change.)							
	n.□□X□		Reserved parameter (Do not change.)							
	n.□X□□		Reserved parameter (Do not change.)							
	n.X□□□		<b>Overtravel Warning Detection Selection</b>							
		0	Do not detect overtravel warnings.							
		1	Detect overtravel warnings.							

Continued on next page.

Continued from previous page.

Parameter No.	Size	Name	Setting Range	Setting Unit	Default Setting	Applicable Motors	When Enabled	Classification	Reference	
Pn00F	2	Application Function Selections F	0000h to 2011h	–	0000h	Rotary	After restart	Setup	*1	
		Preventative Maintenance Warning Selection								
		n.□□□X	0	Do not detect preventative maintenance warnings.						
		n.□□□X	1	Detect preventative maintenance warnings.						
		n.□□X□	Reserved parameter (Do not change.)							
		n.□X□□	Reserved parameter (Do not change.)							
	n.X□□□	Reserved parameter (Do not change.)								
Pn021	2	Reserved parameter (Do not change.)	–	–	0000h	Rotary	–	–	–	
Pn040	2	Reserved parameter (Do not change.)	–	–	0000h	–	–	–	–	
Pn081	2	Application Function Selections 81	0000h to 1111h	–	0000h	Rotary	After restart	Setup	*1	
		Phase-C Pulse Output Selection								
		n.□□□X	0	Output phase-C pulses only in the forward direction.						
		n.□□□X	1	Output phase-C pulses in both the forward and reverse directions.						
		n.□□X□	Reserved parameter (Do not change.)							
		n.□X□□	Reserved parameter (Do not change.)							
	n.X□□□	Reserved parameter (Do not change.)								
Pn100	2	Speed Loop Gain	10 to 20,000	0.1 Hz	400	Rotary	Immediately	Tuning	*1	
Pn101	2	Speed Loop Integral Time Constant	15 to 51,200	0.01 ms	2000	Rotary	Immediately	Tuning	*1	
Pn102	2	Position Loop Gain	10 to 20,000	0.1/s	400	Rotary	Immediately	Tuning	*1	
Pn103	2	Moment of Inertia Ratio	0 to 20,000	1%	100	Rotary	Immediately	Tuning	*1	
Pn104	2	Second Speed Loop Gain	10 to 20,000	0.1 Hz	400	Rotary	Immediately	Tuning	*1	
Pn105	2	Second Speed Loop Integral Time Constant	15 to 51,200	0.01 ms	2000	Rotary	Immediately	Tuning	*1	
Pn106	2	Second Position Loop Gain	10 to 20,000	0.1/s	400	Rotary	Immediately	Tuning	*1	
Pn109	2	Feedforward	0 to 100	1%	0	Rotary	Immediately	Tuning	*1	
Pn10A	2	Feedforward Filter Time Constant	0 to 6,400	0.01 ms	0	Rotary	Immediately	Tuning	*1	

Continued on next page.

Continued from previous page.

Parameter No.	Size	Name	Setting Range	Setting Unit	Default Setting	Applicable Motors	When Enabled	Classification	Reference	
Pn10B	2	Gain Application Selections	0000h to 5334h	–	0000h	Rotary	–	Setup	*1	
	n.□□□X	Mode Switching Selection							When Enabled	Immediately
		0	Use the internal torque reference as the condition (level setting: Pn10C).							
		1	Use the speed reference as the condition (level setting: Pn10D).							
		2	Use the acceleration reference as the condition (level setting: Pn10E).							
		3	Use the position deviation as the condition (level setting: Pn10F).							
	4	Do not use mode switching.								
	n.□□X□	Speed Loop Control Method							When Enabled	After restart
		0	PI control							
		1	I-P control							
2 and 3		Reserved settings (Do not use.)								
n.□X□□	Reserved parameter (Do not change.)									
n.X□□□	Reserved parameter (Do not change.)									
Pn10C	2	Mode Switching Level for Torque Reference	0 to 800	1%	200	Rotary	Immediately	Tuning	*1	
Pn10D	2	Mode Switching Level for Speed Reference	0 to 10,000	1 min <sup>-1</sup>	0	Rotary	Immediately	Tuning	*1	
Pn10E	2	Mode Switching Level for Acceleration	0 to 30,000	1 min <sup>-1</sup> /s	0	Rotary	Immediately	Tuning	*1	
Pn10F	2	Mode Switching Level for Position Deviation	0 to 10,000	1 reference unit	0	Rotary	Immediately	Tuning	*1	
Pn11F	2	Position Integral Time Constant	0 to 50,000	0.1 ms	0	Rotary	Immediately	Tuning	*1	
Pn121	2	Friction Compensation Gain	10 to 1,000	1%	100	Rotary	Immediately	Tuning	*1	
Pn122	2	Second Friction Compensation Gain	10 to 1,000	1%	100	Rotary	Immediately	Tuning	*1	
Pn123	2	Friction Compensation Coefficient	0 to 100	1%	0	Rotary	Immediately	Tuning	*1	
Pn124	2	Friction Compensation Frequency Correction	-10,000 to 10,000	0.1 Hz	0	Rotary	Immediately	Tuning	*1	
Pn125	2	Friction Compensation Gain Correction	1 to 1,000	1%	100	Rotary	Immediately	Tuning	*1	
Pn131	2	Gain Switching Time 1	0 to 65,535	1 ms	0	Rotary	Immediately	Tuning	*1	
Pn132	2	Gain Switching Time 2	0 to 65,535	1 ms	0	Rotary	Immediately	Tuning	*1	
Pn135	2	Gain Switching Waiting Time 1	0 to 65,535	1 ms	0	Rotary	Immediately	Tuning	*1	
Pn136	2	Gain Switching Waiting Time 2	0 to 65,535	1 ms	0	Rotary	Immediately	Tuning	*1	

Continued on next page.

Continued from previous page.

Parameter No.	Size	Name	Setting Range	Setting Unit	Default Setting	Applicable Motors	When Enabled	Classification	Reference	
Pn139	2	Automatic Gain Switching Selections 1	0000h to 0052h	–	0000h	Rotary	Immediately	Tuning	*1	
	n.□□□X	<b>Gain Switching Selection</b>		0	Use manual gain switching. The gain is switched manually with G-SEL in the servo command output signals (SVCMD_IO).					
				1	Reserved setting (Do not use.)					
				2	Use automatic gain switching pattern 1. The gain is switched automatically from the first gain to the second gain when switching condition A is satisfied. The gain is switched automatically from the second gain to the first gain when switching condition A is not satisfied.					
	n.□□X□	<b>Gain Switching Condition A</b>		0	/COIN (Positioning Completion Output) signal turns ON.					
				1	/COIN (Positioning Completion Output) signal turns OFF.					
				2	/NEAR (Near Output) signal turns ON.					
				3	/NEAR (Near Output) signal turns OFF.					
				4	Position reference filter output is 0 and position reference input is OFF.					
				5	Position reference input is ON.					
n.□X□□	Reserved parameter (Do not change.)									
n.X□□□	Reserved parameter (Do not change.)									
Pn13D	2	Current Gain Level	100 to 2,000	1%	2000	Rotary	Immediately	Tuning	*1	
Pn13F	2	Less-Deviation Control 2 Second Position Integral Time Constant	0 to 50,000	0.1 ms	0	Rotary	Immediately	Tuning	–	
Pn140	2	Model Following Control-Related Selections	0000h to 1121h	–	0100h	Rotary	Immediately	Tuning	*1	
	n.□□□X	<b>Model Following Control Selection</b>		0	Do not use model following control.					
				1	Use model following control.					
	n.□□X□	<b>Vibration Suppression Selection</b>		0	Do not perform vibration suppression.					
				1	Perform vibration suppression for a specific frequency.					
				2	Perform vibration suppression for two specific frequencies.					
	n.□X□□	<b>Vibration Suppression Adjustment Selection</b>		0	Do not adjust vibration suppression automatically during execution of autotuning without a host reference, autotuning with a host reference, and custom tuning.					
				1	Adjust vibration suppression automatically during execution of autotuning without a host reference, autotuning with a host reference, and custom tuning.					
	n.X□□□	<b>Speed Feedforward (VFF)/Torque Feedforward (TFF) Selection</b>		0	Do not use model following control and speed/torque feedforward together.					
				1	Use model following control and speed/torque feedforward together.					
Pn141	2	Model Following Control Gain	10 to 20,000	0.1/s	500	Rotary	Immediately	Tuning	*1	
Pn142	2	Model Following Control Gain Correction	500 to 2,000	0.1%	1000	Rotary	Immediately	Tuning	*1	

Continued on next page.

Continued from previous page.

Parameter No.	Size	Name	Setting Range	Setting Unit	Default Setting	Applicable Motors	When Enabled	Classification	Reference	
Pn143	2	Model Following Control Bias in the Forward Direction	0 to 10,000	0.1%	1000	Rotary	Immediately	Tuning	*1	
Pn144	2	Model Following Control Bias in the Reverse Direction	0 to 10,000	0.1%	1000	Rotary	Immediately	Tuning	*1	
Pn145	2	Vibration Suppression 1 Frequency A	10 to 2,500	0.1 Hz	500	Rotary	Immediately	Tuning	*1	
Pn146	2	Vibration Suppression 1 Frequency B	10 to 2,500	0.1 Hz	700	Rotary	Immediately	Tuning	*1	
Pn147	2	Model Following Control Speed Feedforward Compensation	0 to 10,000	0.1%	1000	Rotary	Immediately	Tuning	*1	
Pn148	2	Second Model Following Control Gain	10 to 20,000	0.1/s	500	Rotary	Immediately	Tuning	*1	
Pn149	2	Second Model Following Control Gain Correction	500 to 2,000	0.1%	1000	Rotary	Immediately	Tuning	*1	
Pn14A	2	Vibration Suppression 2 Frequency	10 to 2,000	0.1 Hz	800	Rotary	Immediately	Tuning	*1	
Pn14B	2	Vibration Suppression 2 Correction	10 to 1,000	1%	100	Rotary	Immediately	Tuning	*1	
Pn14F	2	Control-Related Selections	0000h to 0021h	-	0021h	Rotary	After restart	Tuning	*1	
	n.□□□X		<b>Model Following Control Type Selection</b>							
			0	Use model following control type 1.						
			1	Use model following control type 2.						
	n.□□X□		<b>Tuning-less Type Selection</b>							
			0	Use tuning-less type 1.						
			1	Use tuning-less type 2.						
		2	Use tuning-less type 3.							
n.□X□□		Reserved parameter (Do not change.)								
n.X□□□		Reserved parameter (Do not change.)								
Pn160	2	Anti-Resonance Control-Related Selections	0000h to 0011h	-	0010h	Rotary	Immediately	Tuning	*1	
	n.□□□X		<b>Anti-Resonance Control Selection</b>							
			0	Do not use anti-resonance control.						
			1	Use anti-resonance control.						
	n.□□X□		<b>Anti-Resonance Control Adjustment Selection</b>							
			0	Do not adjust anti-resonance control automatically during execution of autotuning without a host reference, autotuning with a host reference, and custom tuning.						
			1	Adjust anti-resonance control automatically during execution of autotuning without a host reference, autotuning with a host reference, and custom tuning.						
n.□X□□		Reserved parameter (Do not change.)								
n.X□□□		Reserved parameter (Do not change.)								
Pn161	2	Anti-Resonance Frequency	10 to 20,000	0.1 Hz	1000	Rotary	Immediately	Tuning	*1	
Pn162	2	Anti-Resonance Gain Correction	1 to 1,000	1%	100	Rotary	Immediately	Tuning	*1	

Continued on next page.

Continued from previous page.

Parameter No.	Size	Name	Setting Range	Setting Unit	Default Setting	Applicable Motors	When Enabled	Classification	Reference	
Pn163	2	Anti-Resonance Damping Gain	0 to 300	1%	0	Rotary	Immediately	Tuning	*1	
Pn164	2	Anti-Resonance Filter Time Constant 1 Correction	-1,000 to 1,000	0.01 ms	0	Rotary	Immediately	Tuning	*1	
Pn165	2	Anti-Resonance Filter Time Constant 2 Correction	-1,000 to 1,000	0.01 ms	0	Rotary	Immediately	Tuning	*1	
Pn166	2	Anti-Resonance Damping Gain 2	0 to 1,000	1%	0	Rotary	Immediately	Tuning	*1	
Pn170	2	Tuning-less Function-Related Selections	0000h to 2711h	-	1401h	Rotary	-	Setup	*1	
	n.□□□X		Tuning-less Selection					When Enabled		
			0	Disable tuning-less function.				After restart		
			1	Enable tuning-less function.						
	n.□□X□		Speed Control Method					When Enabled		
		0	Use for speed control.				After restart			
		1	Use for speed control and use host controller for position control.							
n.□X□□		Rigidity Level					When Enabled			
		0 to 7	Set the rigidity level.				Immediately			
n.X□□□		Tuning-less Load Level					When Enabled			
		0 to 2	Set the load level for the tuning-less function.				Immediately			
Pn205	2	Multiturn Limit	0 to 65,535	1 rev	65535	Rotary	After restart	Setup	*1	
Pn207	2	Position Control Function Selections	0000h to 2210h	-	0010h	Rotary	After restart	Setup	*1	
	n.□□□X		Reserved parameter (Do not change.)							
	n.□□X□		Reserved parameter (Do not change.)							
	n.□X□□		Reserved parameter (Do not change.)							
n.X□□□		/COIN (Positioning Completion Output) Signal Output Timing								
		0	Output when the absolute value of the position deviation is the same or less than the setting of Pn522 (Positioning Completed Width).							
		1	Output when the absolute value of the position error is the same or less than the setting of Pn522 (Positioning Completed Width) and the reference after the position reference filter is 0.							
		2	Output when the absolute value of the position error is the same or less than the setting of Pn522 (Positioning Completed Width) and the reference input is 0.							
Pn20A	4	Number of External Encoder Scale Pitches	4 to 1,048,576	1 scale pitch/revolution	32768	Rotary	After restart	Setup	*1	
Pn20E	4	Electronic Gear Ratio (Numerator)	1 to 1,073,741,824	1	16	Rotary	After restart	Setup	*1	
Pn210	4	Electronic Gear Ratio (Denominator)	1 to 1,073,741,824	1	1	Rotary	After restart	Setup	*1	

Continued on next page.

Continued from previous page.

Parameter No.	Size	Name	Setting Range	Setting Unit	Default Setting	Applicable Motors	When Enabled	Classification	Reference	
Pn22A	2	Fully-closed Control Selections	0000h to 1003h	–	0000h	Rotary	After restart	Setup	*1	
		n.□□□X	Reserved parameter (Do not change.)							
		n.□□X□	Reserved parameter (Do not change.)							
		n.□X□□	Reserved parameter (Do not change.)							
		n.X□□□	Fully-closed Control Speed Feedback Selection							
			0	Use motor encoder speed.						
		1	Use external encoder speed.							
Pn230	2	Position Control Expansion Function Selections	0000h to 0001h	–	0000h	Rotary	After restart	Setup	*1	
		n.□□□X	Backlash Compensation Direction							
			0	Compensate forward references.						
			1	Compensate reverse references.						
		n.□□X□	Reserved parameter (Do not change.)							
		n.□X□□	Reserved parameter (Do not change.)							
	n.X□□□	Reserved parameter (Do not change.)								
Pn231	4	Backlash Compensation	-500,000 to 500,000	0.1 reference units	0	Rotary	Immediately	Setup	*1	
Pn233	2	Backlash Compensation Time Constant	0 to 65,535	0.01 ms	0	Rotary	Immediately	Setup	*1	
Pn281	2	Encoder Output Resolution	1 to 4,096	1 edge/pitch	20	Rotary	After restart	Setup	*1	
Pn304	2	Jogging Speed	0 to 10,000	0.1 min <sup>-1</sup>	500	Rotary	Immediately	Setup	*1	
Pn305	2	Soft Start Acceleration Time	0 to 10,000	1 ms	0	Rotary	Immediately	Setup	*1	
Pn306	2	Soft Start Deceleration Time	0 to 10,000	1 ms	0	Rotary	Immediately	Setup	*1	
Pn308	2	Speed Feedback Filter Time Constant	0 to 65,535	0.01 ms	0	Rotary	Immediately	Setup	*1	
Pn30A	2	Deceleration Time for Servo OFF and Forced Stops	0 to 10,000	1 ms	0	Rotary	Immediately	Setup	*1	
Pn30C	2	Speed Feedforward Average Movement Time	0 to 5,100	0.1 ms	0	Rotary	Immediately	Setup	*1	

Continued on next page.

Continued from previous page.

Parameter No.	Size	Name	Setting Range	Setting Unit	Default Setting	Applicable Motors	When Enabled	Classification	Reference	
Pn310	2	Vibration Detection Selections	0000h to 0002h	–	0000h	Rotary	Immediately	Setup	*1	
		n.□□□X		Vibration Detection Selection						
			0	Do not detect vibration.						
			1	Output a warning (A.911) if vibration is detected.						
			2	Output an alarm (A.520) if vibration is detected.						
			n.□□X□	Reserved parameter (Do not change.)						
		n.□X□□	Reserved parameter (Do not change.)							
		n.X□□□	Reserved parameter (Do not change.)							
Pn311	2	Vibration Detection Sensitivity	50 to 500	1%	100	Rotary	Immediately	Tuning	*1	
Pn312	2	Vibration Detection Level	0 to 5,000	1 min <sup>-1</sup>	50	Rotary	Immediately	Tuning	*1	
Pn316	2	Maximum Motor Speed	0 to 65,535	1 min <sup>-1</sup>	10000	Rotary	After restart	Setup	*1	
Pn324	2	Moment of Inertia Calculation Starting Level	0 to 20,000	1%	300	Rotary	Immediately	Setup	*1	
Pn401	2	First Stage First Torque Reference Filter Time Constant	0 to 65,535	0.01 ms	100	Rotary	Immediately	Tuning	*1	
Pn402	2	Forward Torque Limit	0 to 800	1%*2	800	Rotary	Immediately	Setup	*1	
Pn403	2	Reverse Torque Limit	0 to 800	1%*2	800	Rotary	Immediately	Setup	*1	
Pn404	2	Forward External Torque Limit	0 to 800	1%*2	100	Rotary	Immediately	Setup	*1	
Pn405	2	Reverse External Torque Limit	0 to 800	1%*2	100	Rotary	Immediately	Setup	*1	
Pn406	2	Emergency Stop Torque	0 to 800	1%*2	800	Rotary	Immediately	Setup	*1	
Pn407	2	Speed Limit during Torque Control	0 to 10,000	1 min <sup>-1</sup>	10000	Rotary	Immediately	Setup	*1	

Continued on next page.



Continued from previous page.

Parameter No.	Size	Name	Setting Range	Setting Unit	Default Setting	Applicable Motors	When Enabled	Classification	Reference	
Pn408	2	Torque-Related Function Selections	0000h to 1111h	–	0000h	Rotary	–	Setup	*1	
	n.□□□X	Notch Filter Selection 1							When Enabled	
		0	Disable first stage notch filter.						Immediately	
	1	Enable first stage notch filter.								
	n.□□X□	Speed Limit Selection							When Enabled	
		0	Use the smaller of the maximum motor speed and the setting of Pn407 as the speed limit.						After restart	
	1	Use the smaller of the overspeed alarm detection speed and the setting of Pn407 as the speed limit.								
	n.□X□□	Notch Filter Selection 2							When Enabled	
		0	Disable second stage notch filter.						Immediately	
	1	Enable second stage notch filter.								
	n.X□□□	Friction Compensation Function Selection							When Enabled	
		0	Disable friction compensation.						Immediately	
	1	Enable friction compensation.								
	Pn409	2	First Stage Notch Filter Frequency	50 to 5,000	1 Hz	5000	Rotary	Immediately	Tuning	*1
	Pn40A	2	First Stage Notch Filter Q Value	50 to 1,000	0.01	70	Rotary	Immediately	Tuning	*1
Pn40B	2	First Stage Notch Filter Depth	0 to 1,000	0.001	0	Rotary	Immediately	Tuning	*1	
Pn40C	2	Second Stage Notch Filter Frequency	50 to 5,000	1 Hz	5000	Rotary	Immediately	Tuning	*1	
Pn40D	2	Second Stage Notch Filter Q Value	50 to 1,000	0.01	70	Rotary	Immediately	Tuning	*1	
Pn40E	2	Second Stage Notch Filter Depth	0 to 1,000	0.001	0	Rotary	Immediately	Tuning	*1	
Pn40F	2	Second Stage Second Torque Reference Filter Frequency	100 to 5,000	1 Hz	4000	Rotary	Immediately	Tuning	*1	
Pn410	2	Second Stage Second Notch Filter Q Value	50 to 100	0.01	50	Rotary	Immediately	Tuning	*1	
Pn412	2	First Stage Second Torque Reference Filter Time Constant	0 to 65,535	0.01 ms	100	Rotary	Immediately	Tuning	*1	

Continued on next page.

Continued from previous page.

Parameter No.	Size	Name	Setting Range	Setting Unit	Default Setting	Applicable Motors	When Enabled	Classification	Reference	
Pn416	2	Torque-Related Function Selections 2	0000h to 1111h	-	0000h	Rotary	Immediately	Setup	*1	
	n.□□□X		<b>Notch Filter Selection 3</b>							
			0	Disable third stage notch filter.						
			1	Enable third stage notch filter.						
	n.□□X□		<b>Notch Filter Selection 4</b>							
			0	Disable fourth stage notch filter.						
			1	Enable fourth stage notch filter.						
	n.□X□□		<b>Notch Filter Selection 5</b>							
			0	Disable fifth stage notch filter.						
			1	Enable fifth stage notch filter.						
n.X□□□		<b>Reserved parameter (Do not change.)</b>								
Pn417	2	Third Stage Notch Filter Frequency	50 to 5,000	1 Hz	5000	Rotary	Immediately	Tuning	*1	
Pn418	2	Third Stage Notch Filter Q Value	50 to 1,000	0.01	70	Rotary	Immediately	Tuning	*1	
Pn419	2	Third Stage Notch Filter Depth	0 to 1,000	0.001	0	Rotary	Immediately	Tuning	*1	
Pn41A	2	Fourth Stage Notch Filter Frequency	50 to 5,000	1 Hz	5000	Rotary	Immediately	Tuning	*1	
Pn41B	2	Fourth Stage Notch Filter Q Value	50 to 1,000	0.01	70	Rotary	Immediately	Tuning	*1	
Pn41C	2	Fourth Stage Notch Filter Depth	0 to 1,000	0.001	0	Rotary	Immediately	Tuning	*1	
Pn41D	2	Fifth Stage Notch Filter Frequency	50 to 5,000	1 Hz	5000	Rotary	Immediately	Tuning	*1	
Pn41E	2	Fifth Stage Notch Filter Q Value	50 to 1,000	0.01	70	Rotary	Immediately	Tuning	*1	
Pn41F	2	Fifth Stage Notch Filter Depth	0 to 1,000	0.001	0	Rotary	Immediately	Tuning	*1	
Pn423	2	Speed Ripple Compensation Selections	0000h to 1111h	-	0000h	Rotary	-	Setup	*1	
	n.□□□X		<b>Speed Ripple Compensation Function Selection</b>						<b>When Enabled</b>	
			0	Disable speed ripple compensation.						Immediately
			1	Enable speed ripple compensation.						
	n.□□X□		<b>Speed Ripple Compensation Information Disagreement Warning Detection Selection</b>						<b>When Enabled</b>	
			0	Detect A.942 alarms.						After restart
			1	Do not detect A.942 alarms.						
	n.□X□□		<b>Speed Ripple Compensation Enable Condition Selection</b>						<b>When Enabled</b>	
			0	Speed reference						After restart
			1	Motor speed						
n.X□□□		<b>Reserved parameter (Do not change.)</b>								
Pn424	2	Torque Limit at Main Circuit Voltage Drop	0 to 100	1%*2	50	Rotary	Immediately	Setup	*1	
Pn425	2	Release Time for Torque Limit at Main Circuit Voltage Drop	0 to 1,000	1 ms	100	Rotary	Immediately	Setup	*1	

Continued on next page.

Continued from previous page.

Parameter No.	Size	Name	Setting Range	Setting Unit	Default Setting	Applicable Motors	When Enabled	Classification	Reference	
Pn426	2	Torque Feedforward Average Movement Time	0 to 5,100	0.1 ms	0	Rotary	Immediately	Setup	*1	
Pn427	2	Speed Ripple Compensation Enable Speed	0 to 10,000	1 min <sup>-1</sup>	0	Rotary	Immediately	Tuning	*1	
Pn456	2	Sweep Torque Reference Amplitude	1 to 800	1%	15	Rotary	Immediately	Tuning	*1	
Pn460	2	Notch Filter Adjustment Selections 1	0000h to 0101h	–	0101h	Rotary	Immediately	Tuning	*1	
		<b>Notch Filter Adjustment Selection 1</b>								
		n.□□□X	0	Do not adjust the first stage notch filter automatically during execution of autotuning without a host reference, autotuning with a host reference, and custom tuning.						
		n.□□□X	1	Adjust the first stage notch filter automatically during execution of autotuning without a host reference, autotuning with a host reference, and custom tuning.						
		n.□□X□	Reserved parameter (Do not change.)							
		<b>Notch Filter Adjustment Selection 2</b>								
		n.□X□□	0	Do not adjust the second stage notch filter automatically when the tuning-less function is enabled or during execution of autotuning without a host reference, autotuning with a host reference, and custom tuning.						
	n.X□□□	1	Adjust the second stage notch filter automatically when the tuning-less function is enabled or during execution of autotuning without a host reference, autotuning with a host reference, and custom tuning.							
	n.X□□□	Reserved parameter (Do not change.)								
Pn502	2	Rotation Detection Level	1 to 10,000	1 min <sup>-1</sup>	20	Rotary	Immediately	Setup	*1	
Pn503	2	Speed Coincidence Detection Signal Output Width	0 to 100	1 min <sup>-1</sup>	10	Rotary	Immediately	Setup	*1	
Pn506	2	Brake Reference-Servo OFF Delay Time	0 to 50	10 ms	0	Rotary	Immediately	Setup	*1	
Pn507	2	Brake Reference Output Speed Level	0 to 10,000	1 min <sup>-1</sup>	100	Rotary	Immediately	Setup	*1	
Pn508	2	Servo OFF-Brake Command Waiting Time	10 to 100	10 ms	50	Rotary	Immediately	Setup	*1	
Pn509	2	Momentary Power Interruption Hold Time	20 to 50,000	1 ms	20	Rotary	Immediately	Setup	*1	

Continued on next page.

Continued from previous page.

Parameter No.	Size	Name	Setting Range	Setting Unit	Default Setting	Applicable Motors	When Enabled	Classification	Reference	
Pn50A	2	Input Signal Selections 1	0000h to FFF2h	-	1881h	Rotary	After restart	Setup	*1	
		n.□□□X	Reserved parameter (Do not change.)							
		n.□□X□	Reserved parameter (Do not change.)							
		n.□X□□	Reserved parameter (Do not change.)							
		n.X□□□	P-OT (Forward Drive Prohibit) Signal Allocation							
			0	Enable forward drive when CN1-13 input signal is ON (closed).						
			1	Enable forward drive when CN1-7 input signal is ON (closed).						
			2	Enable forward drive when CN1-8 input signal is ON (closed).						
			3	Enable forward drive when CN1-9 input signal is ON (closed).						
			4	Enable forward drive when CN1-10 input signal is ON (closed).						
			5	Enable forward drive when CN1-11 input signal is ON (closed).						
			6	Enable forward drive when CN1-12 input signal is ON (closed).						
			7	Set the signal to always prohibit forward drive.						
			8	Set the signal to always enable forward drive.						
			9	Enable forward drive when CN1-13 input signal is OFF (open).						
			A	Enable forward drive when CN1-7 input signal is OFF (open).						
			B	Enable forward drive when CN1-8 input signal is OFF (open).						
			C	Enable forward drive when CN1-9 input signal is OFF (open).						
			D	Enable forward drive when CN1-10 input signal is OFF (open).						
		E	Enable forward drive when CN1-11 input signal is OFF (open).							
	F	Enable forward drive when CN1-12 input signal is OFF (open).								

Continued on next page.

Continued from previous page.

Parameter No.	Size	Name	Setting Range	Setting Unit	Default Setting	Applicable Motors	When Enabled	Classification	Reference	
Pn50B	2	Input Signal Selections 2	0000h to FFFFh	-	8882h	Rotary	After restart	Setup	*1	
			<b>N-OT (Reverse Drive Prohibit) Signal Allocation</b>							
			0	Enable reverse drive when CN1-13 input signal is ON (closed).						
			1	Enable reverse drive when CN1-7 input signal is ON (closed).						
			2	Enable reverse drive when CN1-8 input signal is ON (closed).						
			3	Enable reverse drive when CN1-9 input signal is ON (closed).						
			4	Enable reverse drive when CN1-10 input signal is ON (closed).						
			5	Enable reverse drive when CN1-11 input signal is ON (closed).						
			6	Enable reverse drive when CN1-12 input signal is ON (closed).						
	n.□□□X		7	Set the signal to always prohibit reverse drive.						
			8	Set the signal to always enable reverse drive.						
			9	Enable reverse drive when CN1-13 input signal is OFF (open).						
			A	Enable reverse drive when CN1-7 input signal is OFF (open).						
			B	Enable reverse drive when CN1-8 input signal is OFF (open).						
			C	Enable reverse drive when CN1-9 input signal is OFF (open).						
		D	Enable reverse drive when CN1-10 input signal is OFF (open).							
		E	Enable reverse drive when CN1-11 input signal is OFF (open).							
		F	Enable reverse drive when CN1-12 input signal is OFF (open).							
n.□□X□		Reserved parameter (Do not change.)								
		<b>/P-CL (Forward External Torque Limit Input) Signal Allocation</b>								
		0	Active when CN1-13 input signal is ON (closed).							
		1	Active when CN1-7 input signal is ON (closed).							
		2	Active when CN1-8 input signal is ON (closed).							
		3	Active when CN1-9 input signal is ON (closed).							
		4	Active when CN1-10 input signal is ON (closed).							
		5	Active when CN1-11 input signal is ON (closed).							
		6	Active when CN1-12 input signal is ON (closed).							
n.□X□□		7	The signal is always active.							
		8	The signal is always inactive.							
		9	Active when CN1-13 input signal is OFF (open).							
		A	Active when CN1-7 input signal is OFF (open).							
		B	Active when CN1-8 input signal is OFF (open).							
		C	Active when CN1-9 input signal is OFF (open).							
		D	Active when CN1-10 input signal is OFF (open).							
		E	Active when CN1-11 input signal is OFF (open).							
		F	Active when CN1-12 input signal is OFF (open).							
n.X□□□		<b>/N-CL (Reverse External Torque Limit Input) Signal Allocation</b>								
		0 to F	The allocations are the same as the /P-CL (Forward External Torque Limit Input) signal allocations.							

Continued on next page.

Continued from previous page.

Parameter No.	Size	Name	Setting Range	Setting Unit	Default Setting	Applicable Motors	When Enabled	Classification	Reference		
Pn50E	2	Output Signal Selections 1	0000h to 6666h	-	0000h	Rotary	After restart	Setup	*1		
	n.□□□X	<b>/COIN (Positioning Completion Output) Signal Allocation</b>									
		0	Disabled (the above signal output is not used).								
		1	Output the signal from the CN1-1 or CN1-2 output terminal.								
		2	Output the signal from the CN1-23 or CN1-24 output terminal.								
		3	Output the signal from the CN1-25 or CN1-26 output terminal.								
	4 to 6	Reserved setting (Do not use.)									
	n.□□X□	<b>/V-CMP (Speed Coincidence Detection Output) Signal Allocation</b>									
		0 to 6	The allocations are the same as the /COIN (Positioning Completion) signal allocations.								
	n.□X□□	<b>/TGON (Rotation Detection Output) Signal Allocation</b>									
		0 to 6	The allocations are the same as the /COIN (Positioning Completion) signal allocations.								
	n.X□□□	<b>/S-RDY (Servo Ready) Signal Allocation</b>									
		0 to 6	The allocations are the same as the /COIN (Positioning Completion) signal allocations.								
	Pn50F	2	Output Signal Selections 2	0000h to 6666h	-	0100h	Rotary	After restart	Setup	*1	
		n.□□□X	<b>/CLT (Torque Limit Detection Output) Signal Allocation</b>								
			0	Disabled (the above signal output is not used).							
1			Output the signal from the CN1-1 or CN1-2 output terminal.								
2			Output the signal from the CN1-23 or CN1-24 output terminal.								
3			Output the signal from the CN1-25 or CN1-26 output terminal.								
4 to 6		Reserved setting (Do not use.)									
n.□□X□		<b>/MLT (Speed Limit Detection) Signal Allocation</b>									
		0 to 6	The allocations are the same as the /CLT (Torque Limit Detection Output) signal allocations.								
n.□X□□		<b>/BK (Brake Output) Signal Allocation</b>									
		0 to 6	The allocations are the same as the /CLT (Torque Limit Detection Output) signal allocations.								
n.X□□□		<b>/WARN (Warning Output) Signal Allocation</b>									
		0 to 6	The allocations are the same as the /CLT (Torque Limit Detection Output) signal allocations.								

Continued on next page.

Continued from previous page.

Parameter No.	Size	Name	Setting Range	Setting Unit	Default Setting	Applicable Motors	When Enabled	Classification	Reference	
Pn510	2	Output Signal Selections 3	0000h to 0666h	–	0000h	Rotary	After restart	Setup	*1	
		/NEAR (Near Output) Signal Allocation								
		n.□□□X	0	Disabled (the above signal output is not used).						
		n.□□□X	1	Output the signal from the CN1-1 or CN1-2 output terminal.						
		n.□□□X	2	Output the signal from the CN1-23 or CN1-24 output terminal.						
		n.□□□X	3	Output the signal from the CN1-25 or CN1-26 output terminal.						
		n.□□□X	4 to 6	Reserved setting (Do not use.)						
		n.□□X□	Reserved parameter (Do not change.)							
		n.□X□□	Reserved parameter (Do not change.)							
		n.X□□□	Reserved parameter (Do not change.)							

Continued on next page.

Continued from previous page.

Parameter No.	Size	Name	Setting Range	Setting Unit	Default Setting	Applicable Motors	When Enabled	Classification	Reference																																			
Pn511	2	Input Signal Selections 5	0000h to FFFFh	-	6543h	Rotary	After restart	Setup	*1																																			
	n.□□□X		<table border="1"> <thead> <tr> <th colspan="2">/DEC (Origin Return Deceleration Switch Input) Signal Allocation</th> </tr> </thead> <tbody> <tr><td>0</td><td>Active when CN1-13 input signal is ON (closed).</td></tr> <tr><td>1</td><td>Active when CN1-7 input signal is ON (closed).</td></tr> <tr><td>2</td><td>Active when CN1-8 input signal is ON (closed).</td></tr> <tr><td>3</td><td>Active when CN1-9 input signal is ON (closed).</td></tr> <tr><td>4</td><td>Active when CN1-10 input signal is ON (closed).</td></tr> <tr><td>5</td><td>Active when CN1-11 input signal is ON (closed).</td></tr> <tr><td>6</td><td>Active when CN1-12 input signal is ON (closed).</td></tr> <tr><td>7</td><td>The signal is always active.</td></tr> <tr><td>8</td><td>The signal is always inactive.</td></tr> <tr><td>9</td><td>Active when CN1-13 input signal is OFF (open).</td></tr> <tr><td>A</td><td>Active when CN1-7 input signal is OFF (open).</td></tr> <tr><td>B</td><td>Active when CN1-8 input signal is OFF (open).</td></tr> <tr><td>C</td><td>Active when CN1-9 input signal is OFF (open).</td></tr> <tr><td>D</td><td>Active when CN1-10 input signal is OFF (open).</td></tr> <tr><td>E</td><td>Active when CN1-11 input signal is OFF (open).</td></tr> <tr><td>F</td><td>Active when CN1-12 input signal is OFF (open).</td></tr> </tbody> </table>								/DEC (Origin Return Deceleration Switch Input) Signal Allocation		0	Active when CN1-13 input signal is ON (closed).	1	Active when CN1-7 input signal is ON (closed).	2	Active when CN1-8 input signal is ON (closed).	3	Active when CN1-9 input signal is ON (closed).	4	Active when CN1-10 input signal is ON (closed).	5	Active when CN1-11 input signal is ON (closed).	6	Active when CN1-12 input signal is ON (closed).	7	The signal is always active.	8	The signal is always inactive.	9	Active when CN1-13 input signal is OFF (open).	A	Active when CN1-7 input signal is OFF (open).	B	Active when CN1-8 input signal is OFF (open).	C	Active when CN1-9 input signal is OFF (open).	D	Active when CN1-10 input signal is OFF (open).	E	Active when CN1-11 input signal is OFF (open).	F	Active when CN1-12 input signal is OFF (open).
	/DEC (Origin Return Deceleration Switch Input) Signal Allocation																																											
	0	Active when CN1-13 input signal is ON (closed).																																										
	1	Active when CN1-7 input signal is ON (closed).																																										
	2	Active when CN1-8 input signal is ON (closed).																																										
	3	Active when CN1-9 input signal is ON (closed).																																										
	4	Active when CN1-10 input signal is ON (closed).																																										
	5	Active when CN1-11 input signal is ON (closed).																																										
	6	Active when CN1-12 input signal is ON (closed).																																										
	7	The signal is always active.																																										
	8	The signal is always inactive.																																										
	9	Active when CN1-13 input signal is OFF (open).																																										
	A	Active when CN1-7 input signal is OFF (open).																																										
	B	Active when CN1-8 input signal is OFF (open).																																										
	C	Active when CN1-9 input signal is OFF (open).																																										
	D	Active when CN1-10 input signal is OFF (open).																																										
	E	Active when CN1-11 input signal is OFF (open).																																										
	F	Active when CN1-12 input signal is OFF (open).																																										
	n.□□X□		<table border="1"> <thead> <tr> <th colspan="2">/EXT1 (External Latch Input 1) Signal Allocation</th> </tr> </thead> <tbody> <tr><td>0 to 3</td><td>The signal is always inactive.</td></tr> <tr><td>4</td><td>Active when CN1-10 input signal is ON (closed).</td></tr> <tr><td>5</td><td>Active when CN1-11 input signal is ON (closed).</td></tr> <tr><td>6</td><td>Active when CN1-12 input signal is ON (closed).</td></tr> <tr><td>D</td><td>Active when CN1-10 input signal is OFF (open).</td></tr> <tr><td>E</td><td>Active when CN1-11 input signal is OFF (open).</td></tr> <tr><td>F</td><td>Active when CN1-12 input signal is OFF (open).</td></tr> <tr><td>7 to C</td><td>The signal is always inactive.</td></tr> </tbody> </table>								/EXT1 (External Latch Input 1) Signal Allocation		0 to 3	The signal is always inactive.	4	Active when CN1-10 input signal is ON (closed).	5	Active when CN1-11 input signal is ON (closed).	6	Active when CN1-12 input signal is ON (closed).	D	Active when CN1-10 input signal is OFF (open).	E	Active when CN1-11 input signal is OFF (open).	F	Active when CN1-12 input signal is OFF (open).	7 to C	The signal is always inactive.																
	/EXT1 (External Latch Input 1) Signal Allocation																																											
	0 to 3	The signal is always inactive.																																										
	4	Active when CN1-10 input signal is ON (closed).																																										
	5	Active when CN1-11 input signal is ON (closed).																																										
	6	Active when CN1-12 input signal is ON (closed).																																										
	D	Active when CN1-10 input signal is OFF (open).																																										
E	Active when CN1-11 input signal is OFF (open).																																											
F	Active when CN1-12 input signal is OFF (open).																																											
7 to C	The signal is always inactive.																																											
n.□X□□		<table border="1"> <thead> <tr> <th colspan="2">/EXT2 (External Latch Input 2) Signal Allocation</th> </tr> </thead> <tbody> <tr><td>0 to F</td><td>The allocations are the same as the /EXT1 (External Latch Input 1) signal allocations.</td></tr> </tbody> </table>								/EXT2 (External Latch Input 2) Signal Allocation		0 to F	The allocations are the same as the /EXT1 (External Latch Input 1) signal allocations.																															
/EXT2 (External Latch Input 2) Signal Allocation																																												
0 to F	The allocations are the same as the /EXT1 (External Latch Input 1) signal allocations.																																											
n.X□□□		<table border="1"> <thead> <tr> <th colspan="2">/EXT3 (External Latch Input 3) Signal Allocation</th> </tr> </thead> <tbody> <tr><td>0 to F</td><td>The allocations are the same as the /EXT1 (External Latch Input 1) signal allocations.</td></tr> </tbody> </table>								/EXT3 (External Latch Input 3) Signal Allocation		0 to F	The allocations are the same as the /EXT1 (External Latch Input 1) signal allocations.																															
/EXT3 (External Latch Input 3) Signal Allocation																																												
0 to F	The allocations are the same as the /EXT1 (External Latch Input 1) signal allocations.																																											
Pn512	2	Output Signal Inverse Settings	0000h to 1111h	-	0000h	Rotary	After restart	Setup	*1																																			
	n.□□□X		<table border="1"> <thead> <tr> <th colspan="2">Output Signal Inversion for CN1-1 and CN1-2 Terminals</th> </tr> </thead> <tbody> <tr><td>0</td><td>The signal is not inverted.</td></tr> <tr><td>1</td><td>The signal is inverted.</td></tr> </tbody> </table>								Output Signal Inversion for CN1-1 and CN1-2 Terminals		0	The signal is not inverted.	1	The signal is inverted.																												
	Output Signal Inversion for CN1-1 and CN1-2 Terminals																																											
	0	The signal is not inverted.																																										
	1	The signal is inverted.																																										
	n.□□X□		<table border="1"> <thead> <tr> <th colspan="2">Output Signal Inversion for CN1-23 and CN1-24 Terminals</th> </tr> </thead> <tbody> <tr><td>0</td><td>The signal is not inverted.</td></tr> <tr><td>1</td><td>The signal is inverted.</td></tr> </tbody> </table>								Output Signal Inversion for CN1-23 and CN1-24 Terminals		0	The signal is not inverted.	1	The signal is inverted.																												
	Output Signal Inversion for CN1-23 and CN1-24 Terminals																																											
0	The signal is not inverted.																																											
1	The signal is inverted.																																											
n.□X□□		<table border="1"> <thead> <tr> <th colspan="2">Output Signal Inversion for CN1-25 and CN1-26 Terminals</th> </tr> </thead> <tbody> <tr><td>0</td><td>The signal is not inverted.</td></tr> <tr><td>1</td><td>The signal is inverted.</td></tr> </tbody> </table>								Output Signal Inversion for CN1-25 and CN1-26 Terminals		0	The signal is not inverted.	1	The signal is inverted.																													
Output Signal Inversion for CN1-25 and CN1-26 Terminals																																												
0	The signal is not inverted.																																											
1	The signal is inverted.																																											
n.X□□□		Reserved parameter (Do not change.)																																										

Continued on next page.



Continued from previous page.

Parameter No.	Size	Name	Setting Range	Setting Unit	Default Setting	Applicable Motors	When Enabled	Classification	Reference	
Pn514	2	Output Signal Selections 4	0000h to 0666h	-	0000h	Rotary	After restart	Setup	*1	
	n.□□□X		Reserved parameter (Do not change.)							
	n.□□X□		Reserved parameter (Do not change.)							
	n.□X□□		/PM (Preventative Maintenance Output) Signal Allocation							
			0	Disabled (the above signal output is not used).						
			1	Output the signal from the CN1-1 or CN1-2 output terminal.						
			2	Output the signal from the CN1-23 or CN1-24 output terminal.						
			3	Output the signal from the CN1-25 or CN1-26 output terminal.						
			4 to 6	Reserved setting (Do not use.)						
	n.X□□□		Reserved parameter (Do not change.)							
Pn516	2	Input Signal Selections 7	0000h to FFFFh	-	8888h	Rotary	After restart	Setup	*1	
	n.□□□X		FSTP (Forced Stop Input) Signal Allocation							
			0	Enable drive when CN1-13 input signal is ON (closed).						
			1	Enable drive when CN1-7 input signal is ON (closed).						
			2	Enable drive when CN1-8 input signal is ON (closed).						
			3	Enable drive when CN1-9 input signal is ON (closed).						
			4	Enable drive when CN1-10 input signal is ON (closed).						
			5	Enable drive when CN1-11 input signal is ON (closed).						
			6	Enable drive when CN1-12 input signal is ON (closed).						
			7	Set the signal to always prohibit drive (always force the motor to stop).						
			8	Set the signal to always enable drive (always disable forcing the motor to stop).						
			9	Enable drive when CN1-13 input signal is OFF (open).						
			A	Enable drive when CN1-7 input signal is OFF (open).						
			B	Enable drive when CN1-8 input signal is OFF (open).						
			C	Enable drive when CN1-9 input signal is OFF (open).						
	D	Enable drive when CN1-10 input signal is OFF (open).								
	E	Enable drive when CN1-11 input signal is OFF (open).								
	F	Enable drive when CN1-12 input signal is OFF (open).								
	n.□□X□		Reserved parameter (Do not change.)							
	n.□X□□		Reserved parameter (Do not change.)							
n.X□□□		Reserved parameter (Do not change.)								
Pn518*3	-	Safety Module-Related Parameters	-	-	-	Rotary	-	-	-	
Pn51B	4	Motor-Load Position Deviation Overflow Detection Level	0 to 1,073,741,824	1 reference unit	1000	Rotary	Immediately	Setup	*1	
Pn51E	2	Position Deviation Overflow Warning Level	10 to 100	1%	100	Rotary	Immediately	Setup	*1	
Pn520	4	Position Deviation Overflow Alarm Level	1 to 1,073,741,823	1 reference unit	5242880	Rotary	Immediately	Setup	*1	

Continued on next page.

Continued from previous page.

Parameter No.	Size	Name	Setting Range	Setting Unit	Default Setting	Applicable Motors	When Enabled	Classification	Reference	
Pn522	4	Positioning Completed Width	0 to 1,073,741,824	1 reference unit	7	Rotary	Immediately	Setup	*1	
Pn524	4	Near Signal Width	1 to 1,073,741,824	1 reference unit	1073741824	Rotary	Immediately	Setup	*1	
Pn526	4	Position Deviation Overflow Alarm Level at Servo ON	1 to 1,073,741,823	1 reference unit	5242880	Rotary	Immediately	Setup	*1	
Pn528	2	Position Deviation Overflow Warning Level at Servo ON	10 to 100	1%	100	Rotary	Immediately	Setup	*1	
Pn529	2	Speed Limit Level at Servo ON	0 to 10,000	1 min <sup>-1</sup>	10000	Rotary	Immediately	Setup	*1	
Pn52A	2	Multiplier per Fully-closed Rotation	0 to 100	1%	20	Rotary	Immediately	Tuning	*1	
Pn52B	2	Overload Warning Level	1 to 100	1%	20	Rotary	Immediately	Setup	*1	
Pn52C	2	Base Current Derating at Motor Overload Detection	10 to 100	1%	100	Rotary	After restart	Setup	*1	
Pn52D	2	Reserved parameter (Do not change.)	-	-	50	Rotary	-	-	-	
Pn530	2	Program Jogging-Related Selections	0000h to 0005h	-	0000h	Rotary	Immediately	Setup	*1	
			<b>Program Jogging Operation Pattern</b>							
	n.□□□X		0	(Waiting time in Pn535 → Forward by travel distance in Pn531) × Number of movements in Pn536						
	n.□□□X		1	(Waiting time in Pn535 → Reverse by travel distance in Pn531) × Number of movements in Pn536						
	n.□□□X		2	(Waiting time in Pn535 → Forward by travel distance in Pn531) × Number of movements in Pn536 (Waiting time in Pn535 → Reverse by travel distance in Pn531) × Number of movements in Pn536						
	n.□□□X		3	(Waiting time in Pn535 → Reverse by travel distance in Pn531) × Number of movements in Pn536 (Waiting time in Pn535 → Forward by travel distance in Pn531) × Number of movements in Pn536						
	n.□□□X		4	(Waiting time in Pn535 → Forward by travel distance in Pn531 → Waiting time in Pn535 → Reverse by travel distance in Pn531) × Number of movements in Pn536						
	n.□□□X		5	(Waiting time in Pn535 → Reverse by travel distance in Pn531 → Waiting time in Pn535 → Forward by travel distance in Pn531) × Number of movements in Pn536						
	n.□□□□		Reserved parameter (Do not change.)							
	n.□□□□		Reserved parameter (Do not change.)							
n.X□□□		Reserved parameter (Do not change.)								
Pn531	4	Program Jogging Travel Distance	1 to 1,073,741,824	1 reference unit	32768	Rotary	Immediately	Setup	*1	
Pn533	2	Program Jogging Movement Speed	1 to 10,000	0.1 min <sup>-1</sup>	500	Rotary	Immediately	Setup	*1	
Pn534	2	Program Jogging Acceleration/Deceleration Time	2 to 10,000	1 ms	100	Rotary	Immediately	Setup	*1	
Pn535	2	Program Jogging Waiting Time	0 to 10,000	1 ms	100	Rotary	Immediately	Setup	*1	
Pn536	2	Program Jogging Number of Movements	0 to 1,000	1 time	1	Rotary	Immediately	Setup	*1	

Continued on next page.

Continued from previous page.

Parameter No.	Size	Name	Setting Range	Setting Unit	Default Setting	Applicable Motors	When Enabled	Classification	Reference			
Pn550	2	Analog Monitor 1 Offset Voltage	-10,000 to 10,000	0.1 V	0	Rotary	Immediately	Setup	*1			
Pn551	2	Analog Monitor 2 Offset Voltage	-10,000 to 10,000	0.1 V	0	Rotary	Immediately	Setup	*1			
Pn552	2	Analog Monitor 1 Magnification	-10,000 to 10,000	× 0.01	100	Rotary	Immediately	Setup	*1			
Pn553	2	Analog Monitor 2 Magnification	-10,000 to 10,000	× 0.01	100	Rotary	Immediately	Setup	*1			
Pn55A	2	Power Consumption Monitor Unit Time	1 to 1,440	1 min	1	Rotary	Immediately	Setup	–			
Pn560	2	Residual Vibration Detection Width	1 to 3,000	0.1%	400	Rotary	Immediately	Setup	*1			
Pn561	2	Overshoot Detection Level	0 to 100	1%	100	Rotary	Immediately	Setup	*1			
Pn600	2	Regenerative Resistor Capacity*5	Depends on model.*6	10 W	0	Rotary	Immediately	Setup	*1			
Pn601	2	Dynamic Brake Resistor Allowable Energy Consumption	0 to 65,535	10 J	0	Rotary	After restart	Setup	*7			
Pn603	2	Regenerative Resistance	0 to 65,535	10 mΩ	0	Rotary	Immediately	Setup	*1			
Pn604	2	Dynamic Brake Resistance	0 to 65,535	10 mΩ	0	Rotary	After restart	Setup	*7			
Pn621 to Pn628*4	–	Safety Module-Related Parameters	–	–	–	Rotary	–	–	–			
Pn660	2	Preset Position Output Function Switch	0000h to 0011h	–	0000h	Rotary	After restart	Setup	–			
										High-Speed Output Unit		
										n.□□□X	0	Set the signal output width as a time [μs].
										n.□□□X	1	Set the signal output width as a distance [reference units].
										Normal Output Unit		
										n.□□X□	0	Set the signal output width as a time [ms].
n.□□X□	1	Set the signal output width as a distance [reference units].										
n.□X□□	Reserved parameter (Do not change.)											
n.X□□□	Reserved parameter (Do not change.)											

Continued on next page.

Continued from previous page.

Parameter No.	Size	Name	Setting Range	Setting Unit	Default Setting	Applicable Motors	When Enabled	Classification	Reference	
Pn800	2	Communications Controls	0000h to 1FF3h	–	1040h	Rotary	Immediately	Setup	–	
	n.□□□X		<b>MECHATROLINK Communications Check Mask for Debugging</b>							
			0	Do not mask.						
			1	Ignore MECHATROLINK communications errors (A.E60).						
			2	Ignore WDT errors (A.E50).						
			3	Ignore both MECHATROLINK communications errors (A.E60) and WDT errors (A.E50).						
	n.□□X□		<b>Warning Check Masks</b>							
			0	Do not mask.						
			1	Ignore data setting warnings (A.94□).						
			2	Ignore command warnings (A.95□).						
			3	Ignore both A.94□ and A.95□ warnings.						
			4	Ignore communications warnings (A.96□).						
			5	Ignore both A.94□ and A.96□ warnings.						
			6	Ignore both A.95□ and A.96□ warnings.						
			7	Ignore A.94□, A.95□, and A.96□ warnings.						
			8	Ignore data setting warnings (A.97A and A.97b).						
			9	Ignore A.94□, A.97A, and A.97b warnings.						
			A	Ignore A.95□, A.97A, and A.97b warnings.						
			B	Ignore A.94□, A.95□, A.97A, and A.97b warnings.						
			C	Ignore A.96□, A.97A, and A.97b warnings.						
			D	Ignore A.94□, A.96□, A.97A, and A.97b warnings.						
			E	Ignore A.95□, A.96□, A.97A, and A.97b warnings.						
			F	Ignore A.94□, A.95□, A.96□, A.97A, and A.97b warnings.						
n.□X□□		Reserved parameter (Do not change.)								
n.X□□□		<b>Automatic Warning Clear Selection for Debugging<sup>*7</sup></b>								
M3 <sup>*7</sup>		0	Retain warnings for debugging.							
		1	Automatically clear warnings (MECHATROLINK-III specification).							
Pn801	2	Application Function Selections 6 (Software Limits)	0000h to 0103h	–	0003h	Rotary	Immediately	Setup	*1	
	n.□□□X		<b>Software Limit Selection</b>							
			0	Enable both forward and reverse software limits.						
			1	Disable forward software limit.						
			2	Disable reverse software limit.						
			3	Disable both forward and reverse software limits.						
	n.□□X□		Reserved parameter (Do not change.)							
n.□X□□		<b>Software Limit Check for References</b>								
		0	Do not perform software limit checks for references.							
		1	Perform software limit checks for references.							
n.X□□□		Reserved parameter (Do not change.)								
Pn803	2	Origin Range	0 to 250	1 reference unit	10	Rotary	Immediately	Setup	*2	

Continued on next page.

Continued from previous page.

Parameter No.	Size	Name	Setting Range	Setting Unit	Default Setting	Applicable Motors	When Enabled	Classification	Reference							
Pn804	4	Forward Software Limit	-1,073,741,823 to 1,073,741,823	1 reference unit	1073741823	Rotary	Immediately	Setup	*1							
Pn806	4	Reverse Software Limit	-1,073,741,823 to 1,073,741,823	1 reference unit	-1073741823	Rotary	Immediately	Setup	*1							
Pn808	4	Absolute Encoder Origin Offset	-1,073,741,823 to 1,073,741,823	1 reference unit	0	Rotary	Immediately *8	Setup	*1							
Pn80A	2	First Stage Linear Acceleration Constant	1 to 65,535	10,000 reference units/s <sup>2</sup>	100	Rotary	Immediately *9	Setup	*2							
Pn80B	2	Second Stage Linear Acceleration Constant	1 to 65,535	10,000 reference units/s <sup>2</sup>	100	Rotary	Immediately *9	Setup	*2							
Pn80C	2	Acceleration Constant Switching Speed	0 to 65,535	100 reference units/s	0	Rotary	Immediately *9	Setup	*2							
Pn80D	2	First Stage Linear Deceleration Constant	1 to 65,535	10,000 reference units/s <sup>2</sup>	100	Rotary	Immediately *9	Setup	*2							
Pn80E	2	Second Stage Linear Deceleration Constant	1 to 65,535	10,000 reference units/s <sup>2</sup>	100	Rotary	Immediately *9	Setup	*2							
Pn80F	2	Deceleration Constant Switching Speed	0 to 65,535	100 reference units/s	0	Rotary	Immediately *9	Setup	*2							
Pn810	2	Exponential Acceleration/Deceleration Bias	0 to 65,535	100 reference units/s	0	Rotary	Immediately *10	Setup	*2							
Pn811	2	Exponential Acceleration/Deceleration Time Constant	0 to 5,100	0.1 ms	0	Rotary	Immediately *10	Setup	*2							
Pn812	2	Movement Average Time	0 to 5,100	0.1 ms	0	Rotary	Immediately *10	Setup	*2							
Pn814	4	External Positioning Final Travel Distance	-1,073,741,823 to 1,073,741,823	1 reference unit	100	Rotary	Immediately	Setup	*2							
Pn816	2	Origin Return Mode Settings	0000h to 0001h	-	0000h	Rotary	Immediately	Setup	*12							
			<table border="1"> <thead> <tr> <th colspan="2">Origin Return Direction</th> </tr> </thead> <tbody> <tr> <td>0</td> <td>Return in forward direction.</td> </tr> <tr> <td>1</td> <td>Return in reverse direction.</td> </tr> </tbody> </table>								Origin Return Direction		0	Return in forward direction.	1	Return in reverse direction.
	Origin Return Direction															
	0	Return in forward direction.														
	1	Return in reverse direction.														
		n.□□□□ Reserved parameter (Do not change.)														
		n.□X□□ Reserved parameter (Do not change.)														
		n.X□□□ Reserved parameter (Do not change.)														
Pn817 *14	2	Origin Approach Speed 1	0 to 65,535	100 reference units/s	50	Rotary	Immediately *10	Setup	*2							
Pn818 *15	2	Origin Approach Speed 2	0 to 65,535	100 reference units/s	5	Rotary	Immediately *10	Setup	*2							
Pn819	4	Final Travel Distance for Origin Return	-1,073,741,823 to 1,073,741,823	1 reference unit	100	Rotary	Immediately	Setup	*2							

Continued on next page.

Continued from previous page.

Parameter No.	Size	Name	Setting Range	Setting Unit	Default Setting	Applicable Motors	When Enabled	Classification	Reference	
Pn81E <b>M2</b> *13	2	Input Signal Monitor Selections	0000h to 7777h	–	0000h	Rotary	Immediately	Setup	*12	
			<b>IO12 Signal Mapping</b>							
	n.□□□X		0	Do not map.						
			1	Monitor CN1-13 input terminal.						
			2	Monitor CN1-7 input terminal.						
			3	Monitor CN1-8 input terminal.						
			4	Monitor CN1-9 input terminal.						
			5	Monitor CN1-10 input terminal.						
			6	Monitor CN1-11 input terminal.						
			7	Monitor CN1-12 input terminal.						
			<b>IO13 Signal Mapping</b>							
	n.□□X□		0 to 7	The mappings are the same as the IO12 signal mappings.						
			<b>IO14 Signal Mapping</b>							
	n.□X□□		0 to 7	The mappings are the same as the IO12 signal mappings.						
			<b>IO15 Signal Mapping</b>							
n.X□□□		0 to 7	The mappings are the same as the IO12 signal mappings.							
Pn81F <b>M2</b> *13	2	Command Data Allocations	0000h to 1111h	–	0010h	Rotary	After restart	Setup	*12	
			<b>Option Field Allocation</b>							
	n.□□□X		0	Disable option field allocation.						
			1	Enable option field allocation.						
			<b>Position Control Command TFF/TLIM Allocation</b>							
	n.□□X□		0	Disable allocation.						
			1	Enable allocation.						
	n.□X□□		Reserved parameter (Do not change.)							
	n.X□□□		Reserved parameter (Do not change.)							
	Pn820	4	Forward Latching Area	-2,147,483,648 to 2,147,483,647	1 reference unit	0	Rotary	Immediately	Setup	*2
Pn822	4	Reverse Latching Area	-2,147,483,648 to 2,147,483,647	1 reference unit	0	Rotary	Immediately	Setup	*2	

Continued on next page.

Continued from previous page.

Parameter No.	Size	Name	Setting Range	Setting Unit	Default Setting	Applicable Motors	When Enabled	Classification	Reference																																																																																									
Pn824 <b>M3</b> <sup>*g</sup>	2	Option Monitor 1 Selection	0000h to FFFFh	-	0000h	Rotary	Immediately	Setup	*2																																																																																									
			<table border="1"> <thead> <tr> <th>Setting</th> <th>Monitor</th> </tr> </thead> <tbody> <tr> <td colspan="2"><b>High-Speed Monitor Region</b></td> </tr> <tr> <td>0000h</td> <td>Motor speed [overspeed detection speed<sup>*16</sup>/1000000h]</td> </tr> <tr> <td>0001h</td> <td>Speed reference [overspeed detection speed<sup>*16</sup>/1000000h]</td> </tr> <tr> <td>0002h</td> <td>Torque [maximum torque/1000000h]</td> </tr> <tr> <td>0003h</td> <td>Position deviation (lower 32 bits) [reference units]</td> </tr> <tr> <td>0004h</td> <td>Position deviation (upper 32 bits) [reference units]</td> </tr> <tr> <td>000Ah</td> <td>Encoder count (lower 32 bits) [reference units]</td> </tr> <tr> <td>000Bh</td> <td>Encoder count (upper 32 bits) [reference units]</td> </tr> <tr> <td>000Ch</td> <td>FPG count (lower 32 bits) [reference units]</td> </tr> <tr> <td>000Dh</td> <td>FPG count (upper 32 bits) [reference units]</td> </tr> <tr> <td colspan="2"><b>Low-Speed Monitor Region</b></td> </tr> <tr> <td>0010h</td> <td>Un000: Motor speed [min<sup>-1</sup>]</td> </tr> <tr> <td>0011h</td> <td>Un001: Speed Reference [min<sup>-1</sup>]</td> </tr> <tr> <td>0012h</td> <td>Un002: Torque Reference [%]</td> </tr> <tr> <td>0013h</td> <td>Un003: Rotational Angle 1 [encoder pulses] Number of encoder pulses from origin within one encoder rotation displayed in decimal</td> </tr> <tr> <td>0014h</td> <td>Un004: Rotational Angle 2 [deg] Electrical angle from polarity origin</td> </tr> <tr> <td>0015h</td> <td>Un005: Input Signal Monitor</td> </tr> <tr> <td>0016h</td> <td>Un006: Output Signal Monitor</td> </tr> <tr> <td>0017h</td> <td>Un007: Input Reference Speed [min<sup>-1</sup>]</td> </tr> <tr> <td>0018h</td> <td>Un008: Position Deviation [reference units]</td> </tr> <tr> <td>0019h</td> <td>Un009: Accumulated Load Ratio [%]</td> </tr> <tr> <td>001Ah</td> <td>Un00A: Regenerative Load Ratio [%]</td> </tr> <tr> <td>001Bh</td> <td>Un00B: Dynamic Brake Resistor Power Consumption [%]</td> </tr> <tr> <td>001Ch</td> <td>Un00C: Input Reference Pulse Counter [reference units]</td> </tr> <tr> <td>001Dh</td> <td>Un00D: Feedback Pulse Counter [encoder pulses]</td> </tr> <tr> <td>001Eh</td> <td>Un00E: Fully-closed Loop Feedback Pulse Counter [external encoder resolution]</td> </tr> <tr> <td>0023h</td> <td>Initial multiturn data [Rev]</td> </tr> <tr> <td>0024h</td> <td>Initial incremental data [pulses]</td> </tr> <tr> <td>0040h</td> <td>Un025: SERVOPACK Installation Environment Monitor</td> </tr> <tr> <td>0041h</td> <td>Un026: Servomotor Installation Environment Monitor</td> </tr> <tr> <td>0042h</td> <td>Un027: Built-in Fan Remaining Life Ratio</td> </tr> <tr> <td>0043h</td> <td>Un028: Capacitor Remaining Life Ratio</td> </tr> <tr> <td>0044h</td> <td>Un029: Surge Prevention Circuit Remaining Life Ratio</td> </tr> <tr> <td>0045h</td> <td>Un02A: Dynamic Brake Circuit Remaining Life Ratio</td> </tr> <tr> <td>0046h</td> <td>Un032: Instantaneous Power</td> </tr> <tr> <td>0047h</td> <td>Un033: Power Consumption</td> </tr> <tr> <td>0048h</td> <td>Un034: Cumulative Power Consumption</td> </tr> <tr> <td colspan="2"><b>Low-Speed Monitor Region (Communications module only)</b></td> </tr> <tr> <td>0080h</td> <td>Previous value of latched feedback position (LPOS1) [encoder pulses]</td> </tr> <tr> <td>0081h</td> <td>Previous value of latched feedback position (LPOS2) [encoder pulses]</td> </tr> <tr> <td>0084h</td> <td>Continuous Latch Status (EX STATUS)</td> </tr> <tr> <td colspan="2"><b>All Areas</b></td> </tr> <tr> <td>Other values</td> <td>Reserved settings (Do not use.)</td> </tr> </tbody> </table>								Setting	Monitor	<b>High-Speed Monitor Region</b>		0000h	Motor speed [overspeed detection speed <sup>*16</sup> /1000000h]	0001h	Speed reference [overspeed detection speed <sup>*16</sup> /1000000h]	0002h	Torque [maximum torque/1000000h]	0003h	Position deviation (lower 32 bits) [reference units]	0004h	Position deviation (upper 32 bits) [reference units]	000Ah	Encoder count (lower 32 bits) [reference units]	000Bh	Encoder count (upper 32 bits) [reference units]	000Ch	FPG count (lower 32 bits) [reference units]	000Dh	FPG count (upper 32 bits) [reference units]	<b>Low-Speed Monitor Region</b>		0010h	Un000: Motor speed [min <sup>-1</sup> ]	0011h	Un001: Speed Reference [min <sup>-1</sup> ]	0012h	Un002: Torque Reference [%]	0013h	Un003: Rotational Angle 1 [encoder pulses] Number of encoder pulses from origin within one encoder rotation displayed in decimal	0014h	Un004: Rotational Angle 2 [deg] Electrical angle from polarity origin	0015h	Un005: Input Signal Monitor	0016h	Un006: Output Signal Monitor	0017h	Un007: Input Reference Speed [min <sup>-1</sup> ]	0018h	Un008: Position Deviation [reference units]	0019h	Un009: Accumulated Load Ratio [%]	001Ah	Un00A: Regenerative Load Ratio [%]	001Bh	Un00B: Dynamic Brake Resistor Power Consumption [%]	001Ch	Un00C: Input Reference Pulse Counter [reference units]	001Dh	Un00D: Feedback Pulse Counter [encoder pulses]	001Eh	Un00E: Fully-closed Loop Feedback Pulse Counter [external encoder resolution]	0023h	Initial multiturn data [Rev]	0024h	Initial incremental data [pulses]	0040h	Un025: SERVOPACK Installation Environment Monitor	0041h	Un026: Servomotor Installation Environment Monitor	0042h	Un027: Built-in Fan Remaining Life Ratio	0043h	Un028: Capacitor Remaining Life Ratio	0044h	Un029: Surge Prevention Circuit Remaining Life Ratio	0045h	Un02A: Dynamic Brake Circuit Remaining Life Ratio	0046h	Un032: Instantaneous Power	0047h	Un033: Power Consumption	0048h	Un034: Cumulative Power Consumption	<b>Low-Speed Monitor Region (Communications module only)</b>		0080h	Previous value of latched feedback position (LPOS1) [encoder pulses]	0081h	Previous value of latched feedback position (LPOS2) [encoder pulses]	0084h	Continuous Latch Status (EX STATUS)	<b>All Areas</b>		Other values	Reserved settings (Do not use.)
	Setting	Monitor																																																																																																
	<b>High-Speed Monitor Region</b>																																																																																																	
	0000h	Motor speed [overspeed detection speed <sup>*16</sup> /1000000h]																																																																																																
	0001h	Speed reference [overspeed detection speed <sup>*16</sup> /1000000h]																																																																																																
	0002h	Torque [maximum torque/1000000h]																																																																																																
	0003h	Position deviation (lower 32 bits) [reference units]																																																																																																
	0004h	Position deviation (upper 32 bits) [reference units]																																																																																																
	000Ah	Encoder count (lower 32 bits) [reference units]																																																																																																
	000Bh	Encoder count (upper 32 bits) [reference units]																																																																																																
	000Ch	FPG count (lower 32 bits) [reference units]																																																																																																
	000Dh	FPG count (upper 32 bits) [reference units]																																																																																																
	<b>Low-Speed Monitor Region</b>																																																																																																	
	0010h	Un000: Motor speed [min <sup>-1</sup> ]																																																																																																
	0011h	Un001: Speed Reference [min <sup>-1</sup> ]																																																																																																
	0012h	Un002: Torque Reference [%]																																																																																																
	0013h	Un003: Rotational Angle 1 [encoder pulses] Number of encoder pulses from origin within one encoder rotation displayed in decimal																																																																																																
	0014h	Un004: Rotational Angle 2 [deg] Electrical angle from polarity origin																																																																																																
	0015h	Un005: Input Signal Monitor																																																																																																
	0016h	Un006: Output Signal Monitor																																																																																																
	0017h	Un007: Input Reference Speed [min <sup>-1</sup> ]																																																																																																
	0018h	Un008: Position Deviation [reference units]																																																																																																
	0019h	Un009: Accumulated Load Ratio [%]																																																																																																
	001Ah	Un00A: Regenerative Load Ratio [%]																																																																																																
	001Bh	Un00B: Dynamic Brake Resistor Power Consumption [%]																																																																																																
	001Ch	Un00C: Input Reference Pulse Counter [reference units]																																																																																																
	001Dh	Un00D: Feedback Pulse Counter [encoder pulses]																																																																																																
	001Eh	Un00E: Fully-closed Loop Feedback Pulse Counter [external encoder resolution]																																																																																																
	0023h	Initial multiturn data [Rev]																																																																																																
	0024h	Initial incremental data [pulses]																																																																																																
	0040h	Un025: SERVOPACK Installation Environment Monitor																																																																																																
	0041h	Un026: Servomotor Installation Environment Monitor																																																																																																
	0042h	Un027: Built-in Fan Remaining Life Ratio																																																																																																
	0043h	Un028: Capacitor Remaining Life Ratio																																																																																																
	0044h	Un029: Surge Prevention Circuit Remaining Life Ratio																																																																																																
	0045h	Un02A: Dynamic Brake Circuit Remaining Life Ratio																																																																																																
	0046h	Un032: Instantaneous Power																																																																																																
	0047h	Un033: Power Consumption																																																																																																
	0048h	Un034: Cumulative Power Consumption																																																																																																
	<b>Low-Speed Monitor Region (Communications module only)</b>																																																																																																	
	0080h	Previous value of latched feedback position (LPOS1) [encoder pulses]																																																																																																
	0081h	Previous value of latched feedback position (LPOS2) [encoder pulses]																																																																																																
	0084h	Continuous Latch Status (EX STATUS)																																																																																																
	<b>All Areas</b>																																																																																																	
	Other values	Reserved settings (Do not use.)																																																																																																

Continued on next page.

Continued from previous page.

Parameter No.	Size	Name	Setting Range	Setting Unit	Default Setting	Applicable Motors	When Enabled	Classification	Reference			
Pn825	2	Option Monitor 2 Selection	0000h to FFFFh	-	0000h	Rotary	Immediately	Setup	*2			
		0000h to 0084h	The settings are the same as those for the Option Monitor 1 Selection.									
Pn827	2	Linear Deceleration Constant 1 for Stopping	1 to 65,535	10,000 reference units/s <sup>2</sup>	100	Rotary	Immediately *9	Setup	*2			
Pn829	2	SVOFF Waiting Time (for SVOFF at Deceleration to Stop)	0 to 65,535	10 ms	0	Rotary	Immediately *9	Setup	*2			
Pn82A <b>M2</b> *13	2	Option Field Allocations 1	0000h to 1E1Eh	-	1813h	Rotary	After restart	Setup	*12			
										<b>ACCFIL Allocation (Option)</b>		
										n.□□□X	0	Allocate bits 0 and 1 to ACCFIL.
											1	Allocate bits 1 and 2 to ACCFIL.
											2	Allocate bits 2 and 3 to ACCFIL.
											3	Allocate bits 3 and 4 to ACCFIL.
											4	Allocate bits 4 and 5 to ACCFIL.
											5	Allocate bits 5 and 6 to ACCFIL.
											6	Allocate bits 6 and 7 to ACCFIL.
											7	Allocate bits 7 and 8 to ACCFIL.
											8	Allocate bits 8 and 9 to ACCFIL.
											9	Allocate bits 9 and 10 to ACCFIL.
											A	Allocate bits 10 and 11 to ACCFIL.
											B	Allocate bits 11 and 12 to ACCFIL.
											C	Allocate bits 12 and 13 to ACCFIL.
D	Allocate bits 13 and 14 to ACCFIL.											
E	Allocate bits 14 and 15 to ACCFIL.											
<b>ACCFIL Allocation Enable/Disable Selection</b>												
n.□□X□	0	Disable ACCFIL allocation.										
	1	Enable ACCFIL allocation.										
<b>G_SEL Allocation (Option)</b>												
n.□X□□	0 to E	The settings are the same as for the ACCFIL allocations.										
<b>G_SEL Allocation Enable/Disable Selection</b>												
n.X□□□	0	Disable G_SEL allocation.										
	1	Enable G_SEL allocation.										

Continued on next page.



Continued from previous page.

Parameter No.	Size	Name	Setting Range	Setting Unit	Default Setting	Applicable Motors	When Enabled	Classification	Reference																																			
Pn82B <b>M2</b> <sup>*13</sup>	2	Option Field Allocations <sup>2</sup>	0000h to 1F1Fh	–	1D1Ch	Rotary	After restart	Setup	*12																																			
	n.□□□X		<table border="1"> <thead> <tr> <th colspan="2">V_PPI Allocation (Option)</th> </tr> </thead> <tbody> <tr><td>0</td><td>Allocate bit 0 to V_PPI.</td></tr> <tr><td>1</td><td>Allocate bit 1 to V_PPI.</td></tr> <tr><td>2</td><td>Allocate bit 2 to V_PPI.</td></tr> <tr><td>3</td><td>Allocate bit 3 to V_PPI.</td></tr> <tr><td>4</td><td>Allocate bit 4 to V_PPI.</td></tr> <tr><td>5</td><td>Allocate bit 5 to V_PPI.</td></tr> <tr><td>6</td><td>Allocate bit 6 to V_PPI.</td></tr> <tr><td>7</td><td>Allocate bit 7 to V_PPI.</td></tr> <tr><td>8</td><td>Allocate bit 8 to V_PPI.</td></tr> <tr><td>9</td><td>Allocate bit 9 to V_PPI.</td></tr> <tr><td>A</td><td>Allocate bit 10 to V_PPI.</td></tr> <tr><td>B</td><td>Allocate bit 11 to V_PPI.</td></tr> <tr><td>C</td><td>Allocate bit 12 to V_PPI.</td></tr> <tr><td>D</td><td>Allocate bit 13 to V_PPI.</td></tr> <tr><td>E</td><td>Allocate bit 14 to V_PPI.</td></tr> <tr><td>F</td><td>Allocate bit 15 to V_PPI.</td></tr> </tbody> </table>								V_PPI Allocation (Option)		0	Allocate bit 0 to V_PPI.	1	Allocate bit 1 to V_PPI.	2	Allocate bit 2 to V_PPI.	3	Allocate bit 3 to V_PPI.	4	Allocate bit 4 to V_PPI.	5	Allocate bit 5 to V_PPI.	6	Allocate bit 6 to V_PPI.	7	Allocate bit 7 to V_PPI.	8	Allocate bit 8 to V_PPI.	9	Allocate bit 9 to V_PPI.	A	Allocate bit 10 to V_PPI.	B	Allocate bit 11 to V_PPI.	C	Allocate bit 12 to V_PPI.	D	Allocate bit 13 to V_PPI.	E	Allocate bit 14 to V_PPI.	F	Allocate bit 15 to V_PPI.
	V_PPI Allocation (Option)																																											
	0	Allocate bit 0 to V_PPI.																																										
	1	Allocate bit 1 to V_PPI.																																										
	2	Allocate bit 2 to V_PPI.																																										
	3	Allocate bit 3 to V_PPI.																																										
	4	Allocate bit 4 to V_PPI.																																										
	5	Allocate bit 5 to V_PPI.																																										
	6	Allocate bit 6 to V_PPI.																																										
	7	Allocate bit 7 to V_PPI.																																										
	8	Allocate bit 8 to V_PPI.																																										
	9	Allocate bit 9 to V_PPI.																																										
	A	Allocate bit 10 to V_PPI.																																										
	B	Allocate bit 11 to V_PPI.																																										
	C	Allocate bit 12 to V_PPI.																																										
	D	Allocate bit 13 to V_PPI.																																										
	E	Allocate bit 14 to V_PPI.																																										
	F	Allocate bit 15 to V_PPI.																																										
	n.□□X□		<table border="1"> <thead> <tr> <th colspan="2">V_PPI Allocation Enable/Disable Selection</th> </tr> </thead> <tbody> <tr><td>0</td><td>Disable V_PPI allocation.</td></tr> <tr><td>1</td><td>Enable V_PPI allocation.</td></tr> </tbody> </table>								V_PPI Allocation Enable/Disable Selection		0	Disable V_PPI allocation.	1	Enable V_PPI allocation.																												
V_PPI Allocation Enable/Disable Selection																																												
0	Disable V_PPI allocation.																																											
1	Enable V_PPI allocation.																																											
n.□X□□		<table border="1"> <thead> <tr> <th colspan="2">P_PI_CLR Allocation (Option)</th> </tr> </thead> <tbody> <tr><td>0 to F</td><td>The settings are the same as for the V_PPI allocations.</td></tr> </tbody> </table>								P_PI_CLR Allocation (Option)		0 to F	The settings are the same as for the V_PPI allocations.																															
P_PI_CLR Allocation (Option)																																												
0 to F	The settings are the same as for the V_PPI allocations.																																											
n.X□□□		<table border="1"> <thead> <tr> <th colspan="2">P_PI_CLR Allocation Enable/Disable Selection</th> </tr> </thead> <tbody> <tr><td>0</td><td>Disable P_PI_CLR allocation.</td></tr> <tr><td>1</td><td>Enable P_PI_CLR allocation.</td></tr> </tbody> </table>								P_PI_CLR Allocation Enable/Disable Selection		0	Disable P_PI_CLR allocation.	1	Enable P_PI_CLR allocation.																													
P_PI_CLR Allocation Enable/Disable Selection																																												
0	Disable P_PI_CLR allocation.																																											
1	Enable P_PI_CLR allocation.																																											
Pn82C <b>M2</b> <sup>*13</sup>	2	Option Field Allocations <sup>3</sup>	0000h to 1F1Fh	–	1F1Eh	Rotary	After restart	Setup	*12																																			
	n.□□□X		<table border="1"> <thead> <tr> <th colspan="2">P_CL Allocation (Option)</th> </tr> </thead> <tbody> <tr><td>0 to F</td><td>The settings are the same as for the V_PPI allocations.</td></tr> </tbody> </table>								P_CL Allocation (Option)		0 to F	The settings are the same as for the V_PPI allocations.																														
	P_CL Allocation (Option)																																											
	0 to F	The settings are the same as for the V_PPI allocations.																																										
	n.□□X□		<table border="1"> <thead> <tr> <th colspan="2">P_CL Allocation Enable/Disable Selection</th> </tr> </thead> <tbody> <tr><td>0</td><td>Disable P_CL allocation.</td></tr> <tr><td>1</td><td>Enable P_CL allocation.</td></tr> </tbody> </table>								P_CL Allocation Enable/Disable Selection		0	Disable P_CL allocation.	1	Enable P_CL allocation.																												
	P_CL Allocation Enable/Disable Selection																																											
	0	Disable P_CL allocation.																																										
	1	Enable P_CL allocation.																																										
n.□X□□		<table border="1"> <thead> <tr> <th colspan="2">N_CL Allocation (Option)</th> </tr> </thead> <tbody> <tr><td>0 to F</td><td>The settings are the same as for the V_PPI allocations.</td></tr> </tbody> </table>								N_CL Allocation (Option)		0 to F	The settings are the same as for the V_PPI allocations.																															
N_CL Allocation (Option)																																												
0 to F	The settings are the same as for the V_PPI allocations.																																											
n.X□□□		<table border="1"> <thead> <tr> <th colspan="2">N_CL Allocation Enable/Disable Selection</th> </tr> </thead> <tbody> <tr><td>0</td><td>Disable N_CL allocation.</td></tr> <tr><td>1</td><td>Enable N_CL allocation.</td></tr> </tbody> </table>								N_CL Allocation Enable/Disable Selection		0	Disable N_CL allocation.	1	Enable N_CL allocation.																													
N_CL Allocation Enable/Disable Selection																																												
0	Disable N_CL allocation.																																											
1	Enable N_CL allocation.																																											

Continued on next page.

Continued from previous page.

Parameter No.	Size	Name	Setting Range	Setting Unit	Default Setting	Applicable Motors	When Enabled	Classification	Reference																																												
Pn82D <b>M2</b> *13	2	Option Field Allocations	0000h to 1F1Ch	-	0000h	Rotary	After restart	Setup	*12																																												
	4	<table border="1"> <thead> <tr> <th colspan="2">BANK_SEL1 Allocation (Option)</th> </tr> </thead> <tbody> <tr><td>0</td><td>Allocate bits 0 to 3 to BANK_SEL1.</td></tr> <tr><td>1</td><td>Allocate bits 1 to 4 to BANK_SEL1.</td></tr> <tr><td>2</td><td>Allocate bits 2 to 5 to BANK_SEL1.</td></tr> <tr><td>3</td><td>Allocate bits 3 to 6 to BANK_SEL1.</td></tr> <tr><td>4</td><td>Allocate bits 4 to 7 to BANK_SEL1.</td></tr> <tr><td>5</td><td>Allocate bits 5 to 8 to BANK_SEL1.</td></tr> <tr><td>6</td><td>Allocate bits 6 to 9 to BANK_SEL1.</td></tr> <tr><td>7</td><td>Allocate bits 7 to 10 to BANK_SEL1.</td></tr> <tr><td>8</td><td>Allocate bits 8 to 11 to BANK_SEL1.</td></tr> <tr><td>9</td><td>Allocate bits 9 to 12 to BANK_SEL1.</td></tr> <tr><td>A</td><td>Allocate bits 10 to 13 to BANK_SEL1.</td></tr> <tr><td>B</td><td>Allocate bits 11 to 14 to BANK_SEL1.</td></tr> <tr><td>C</td><td>Allocate bits 12 to 15 to BANK_SEL1.</td></tr> </tbody> </table> <table border="1"> <thead> <tr> <th colspan="2">BANK_SEL1 Allocation Enable/Disable Selection</th> </tr> </thead> <tbody> <tr><td>0</td><td>Disable BANK_SEL1 allocation.</td></tr> <tr><td>1</td><td>Enable BANK_SEL1 allocation.</td></tr> </tbody> </table> <table border="1"> <thead> <tr> <th colspan="2">LT_DISABLE Allocation (Option)</th> </tr> </thead> <tbody> <tr><td>0 to F</td><td>The settings are the same as for the V_PPI allocations.</td></tr> </tbody> </table> <table border="1"> <thead> <tr> <th colspan="2">LT_DISABLE Allocation Enable/Disable Selection</th> </tr> </thead> <tbody> <tr><td>0</td><td>Disable LT_DISABLE allocation.</td></tr> <tr><td>1</td><td>Enable LT_DISABLE allocation.</td></tr> </tbody> </table>								BANK_SEL1 Allocation (Option)		0	Allocate bits 0 to 3 to BANK_SEL1.	1	Allocate bits 1 to 4 to BANK_SEL1.	2	Allocate bits 2 to 5 to BANK_SEL1.	3	Allocate bits 3 to 6 to BANK_SEL1.	4	Allocate bits 4 to 7 to BANK_SEL1.	5	Allocate bits 5 to 8 to BANK_SEL1.	6	Allocate bits 6 to 9 to BANK_SEL1.	7	Allocate bits 7 to 10 to BANK_SEL1.	8	Allocate bits 8 to 11 to BANK_SEL1.	9	Allocate bits 9 to 12 to BANK_SEL1.	A	Allocate bits 10 to 13 to BANK_SEL1.	B	Allocate bits 11 to 14 to BANK_SEL1.	C	Allocate bits 12 to 15 to BANK_SEL1.	BANK_SEL1 Allocation Enable/Disable Selection		0	Disable BANK_SEL1 allocation.	1	Enable BANK_SEL1 allocation.	LT_DISABLE Allocation (Option)		0 to F	The settings are the same as for the V_PPI allocations.	LT_DISABLE Allocation Enable/Disable Selection		0	Disable LT_DISABLE allocation.	1	Enable LT_DISABLE allocation.
	BANK_SEL1 Allocation (Option)																																																				
	0	Allocate bits 0 to 3 to BANK_SEL1.																																																			
	1	Allocate bits 1 to 4 to BANK_SEL1.																																																			
	2	Allocate bits 2 to 5 to BANK_SEL1.																																																			
	3	Allocate bits 3 to 6 to BANK_SEL1.																																																			
	4	Allocate bits 4 to 7 to BANK_SEL1.																																																			
	5	Allocate bits 5 to 8 to BANK_SEL1.																																																			
	6	Allocate bits 6 to 9 to BANK_SEL1.																																																			
	7	Allocate bits 7 to 10 to BANK_SEL1.																																																			
	8	Allocate bits 8 to 11 to BANK_SEL1.																																																			
	9	Allocate bits 9 to 12 to BANK_SEL1.																																																			
	A	Allocate bits 10 to 13 to BANK_SEL1.																																																			
	B	Allocate bits 11 to 14 to BANK_SEL1.																																																			
	C	Allocate bits 12 to 15 to BANK_SEL1.																																																			
	BANK_SEL1 Allocation Enable/Disable Selection																																																				
	0	Disable BANK_SEL1 allocation.																																																			
	1	Enable BANK_SEL1 allocation.																																																			
	LT_DISABLE Allocation (Option)																																																				
0 to F	The settings are the same as for the V_PPI allocations.																																																				
LT_DISABLE Allocation Enable/Disable Selection																																																					
0	Disable LT_DISABLE allocation.																																																				
1	Enable LT_DISABLE allocation.																																																				

Continued on next page.

Continued from previous page.

Parameter No.	Size	Name	Setting Range	Setting Unit	Default Setting	Applicable Motors	When Enabled	Classification	Reference	
Pn82E <b>M2</b> <sup>*13</sup>	2	Option Field Allocations <sup>5</sup>	0000h to 1D1Fh	-	0000h	Rotary	After restart	Setup	*12	
		n.□□□X	Reserved parameter (Do not change.)							
		n.□□X□	Reserved parameter (Do not change.)							
		n.□X□□	OUT_SIGNAL Allocation (Option)							
			0	Allocate bits 0 to 2 to OUT_SIGNAL.						
			1	Allocate bits 1 to 3 to OUT_SIGNAL.						
			2	Allocate bits 2 to 4 to OUT_SIGNAL.						
			3	Allocate bits 3 to 5 to OUT_SIGNAL.						
			4	Allocate bits 4 to 6 to OUT_SIGNAL.						
			5	Allocate bits 5 to 7 to OUT_SIGNAL.						
			6	Allocate bits 6 to 8 to OUT_SIGNAL.						
			7	Allocate bits 7 to 9 to OUT_SIGNAL.						
			8	Allocate bits 8 to 10 to OUT_SIGNAL.						
			9	Allocate bits 9 to 11 to OUT_SIGNAL.						
		A	Allocate bits 10 to 12 to OUT_SIGNAL.							
		B	Allocate bits 11 to 13 to OUT_SIGNAL.							
		C	Allocate bits 12 to 14 to OUT_SIGNAL.							
	D	Allocate bits 13 to 15 to OUT_SIGNAL.								
	n.X□□□	OUT_SIGNAL Allocation Enable/Disable Selection								
		0	Disable OUT_SIGNAL allocation.							
		1	Enable OUT_SIGNAL allocation.							
Pn833	2	Motion Settings	0000h to 0001h	-	0000h	Rotary	After restart	Setup	*2	
		n.□□□X	Linear Acceleration/Deceleration Constant Selection							
			0	Use Pn80A to Pn80F and Pn827. (The settings of Pn834 to Pn840 are ignored.)						
			1	Use Pn834 to Pn840. (The settings of Pn80A to Pn80F and Pn827 are ignored.)						
		n.□□X□	Reserved parameter (Do not change.)							
		n.□X□□	Reserved parameter (Do not change.)							
	n.X□□□	Reserved parameter (Do not change.)								
Pn834	4	First Stage Linear Acceleration Constant 2	1 to 20,971,520	10,000 reference units/s <sup>2</sup>	100	Rotary	Immediately <sup>*9</sup>	Setup	*2	
Pn836	4	Second Stage Linear Acceleration Constant 2	1 to 20,971,520	10,000 reference units/s <sup>2</sup>	100	Rotary	Immediately <sup>*9</sup>	Setup	*2	
Pn838	4	Acceleration Constant Switching Speed 2	0 to 2,097,152,000	1 reference unit/s	0	Rotary	Immediately <sup>*9</sup>	Setup	*2	
Pn83A	4	First Stage Linear Deceleration Constant 2	1 to 20,971,520	10,000 reference units/s <sup>2</sup>	100	Rotary	Immediately <sup>*9</sup>	Setup	*2	

Continued on next page.

Continued from previous page.

Parameter No.	Size	Name	Setting Range	Setting Unit	Default Setting	Applicable Motors	When Enabled	Classification	Reference
Pn83C	4	Second Stage Linear Deceleration Constant 2	1 to 20,971,520	10,000 reference units/s <sup>2</sup>	100	Rotary	Immediately *10	Setup	*2
Pn83E	4	Deceleration Constant Switching Speed 2	0 to 2,097,152,000	1 reference unit/s	0	Rotary	Immediately *10	Setup	*2
Pn840	4	Linear Deceleration Constant 2 for Stopping	1 to 20,971,520	10,000 reference units/s <sup>2</sup>	100	Rotary	Immediately *10	Setup	*2
Pn842 *14	4	Second Origin Approach Speed 1	0 to 20,971,520	100 reference units/s	0	Rotary	Immediately *10	Setup	*2
Pn844 *15	4	Second Origin Approach Speed 2	0 to 20,971,520	100 reference units/s	0	Rotary	Immediately *10	Setup	*2
Pn846	2	POSING Command Scurve Acceleration/Deceleration Rate	0 to 50	1%	0	Rotary	Immediately *10	Setup	–
Pn850	2	Number of Latch Sequences	0 to 8	–	0	Rotary	Immediately	Setup	*2
Pn851	2	Continuous Latch Sequence Count	0 to 255	–	0	Rotary	Immediately	Setup	*2
Pn852	2	Latch Sequence 1 to 4 Settings	0000h to 3333h	–	0000h	Rotary	Immediately	Setup	*2
		<b>Latch Sequence 1 Signal Selection</b>							
	n.□□□X	0	Phase C						
		1	EXT1 signal						
		2	EXT2 signal						
		3	EXT3 signal						
		<b>Latch Sequence 2 Signal Selection</b>							
n.□□X□	0 to 3	The settings are the same as those for the Latch Sequence 1 Signal Selection.							
	<b>Latch Sequence 3 Signal Selection</b>								
n.□X□□	0 to 3	The settings are the same as those for the Latch Sequence 1 Signal Selection.							
	<b>Latch Sequence 4 Signal Selection</b>								
n.X□□□	0 to 3	The settings are the same as those for the Latch Sequence 1 Signal Selection.							

Continued on next page.

Continued from previous page.

Parameter No.	Size	Name	Setting Range	Setting Unit	Default Setting	Applicable Motors	When Enabled	Classification	Reference	
Pn853	2	Latch Sequence 5 to 8 Settings	0000h to 3333h	–	0000h	Rotary	Immediately	Setup	*2	
	n.□□□X	<b>Latch Sequence 5 Signal Selection</b>								
		0	Phase C							
		1	EXT1 signal							
		2	EXT2 signal							
	n.□□X□	<b>Latch Sequence 6 Signal Selection</b>								
		0 to 3	The settings are the same as those for the Latch Sequence 5 Signal Selection.							
	n.□X□□	<b>Latch Sequence 7 Signal Selection</b>								
		0 to 3	The settings are the same as those for the Latch Sequence 5 Signal Selection.							
	n.X□□□	<b>Latch Sequence 8 Signal Selection</b>								
		0 to 3	The settings are the same as those for the Latch Sequence 5 Signal Selection.							
	Pn860 <b>M3</b> *8	2	SVCMD_IO Input Signal Monitor Allocations 1	0000h to 1717h	–	0000h	Rotary	Immediately	Setup	*2
n.□□□X		<b>Input Signal Monitor Allocation for CN1-13 (SVCMD_IO)</b>								
		0	Allocate bit 24 (IO_STS1) to CN1-13 input signal monitor.							
		1	Allocate bit 25 (IO_STS2) to CN1-13 input signal monitor.							
		2	Allocate bit 26 (IO_STS3) to CN1-13 input signal monitor.							
		3	Allocate bit 27 (IO_STS4) to CN1-13 input signal monitor.							
		4	Allocate bit 28 (IO_STS5) to CN1-13 input signal monitor.							
		5	Allocate bit 29 (IO_STS6) to CN1-13 input signal monitor.							
		6	Allocate bit 30 (IO_STS7) to CN1-13 input signal monitor.							
n.□□X□		<b>CN1-13 Input Signal Monitor Enable/Disable Selection</b>								
		0	Disable allocation for CN1-13 input signal monitor.							
n.□X□□		<b>Input Signal Monitor Allocation for CN1-7 (SVCMD_IO)</b>								
	0 to 7	The settings are the same as the CN1-13 allocations.								
n.X□□□	<b>CN1-7 Input Signal Monitor Enable/Disable Selection</b>									
	0	Disable allocation for CN1-7 input signal monitor.								
1	Enable allocation for CN1-7 input signal monitor.									

Continued on next page.

Continued from previous page.

Parameter No.	Size	Name	Setting Range	Setting Unit	Default Setting	Applicable Motors	When Enabled	Classification	Reference
Pn861 <b>M3</b> *8	2	SVCMD_IO Input Signal Monitor Allocations 2	0000h to 1717h	-	0000h	Rotary	Immediately	Setup	*2
	n.□□□X	Input Signal Monitor Allocation for CN1-8 (SVCMD_IO)							
		0 to 7	The settings are the same as the CN1-13 allocations.						
	n.□□X□	CN1-8 Input Signal Monitor Enable/Disable Selection							
		0	Disable allocation for CN1-8 input signal monitor.						
		1	Enable allocation for CN1-8 input signal monitor.						
	n.□X□□	Input Signal Monitor Allocation for CN1-9 (SVCMD_IO)							
		0 to 7	The settings are the same as the CN1-13 allocations.						
	n.X□□□	CN1-9 Input Signal Monitor Enable/Disable Selection							
		0	Disable allocation for CN1-9 input signal monitor.						
	1	Enable allocation for CN1-9 input signal monitor.							
Pn862 <b>M3</b> *8	2	SVCMD_IO Input Signal Monitor Allocations 3	0000h to 1717h	-	0000h	Rotary	Immediately	Setup	*2
	n.□□□X	Input Signal Monitor Allocation for CN1-10 (SVCMD_IO)							
		0 to 7	The settings are the same as the CN1-13 allocations.						
	n.□□X□	CN1-10 Input Signal Monitor Enable/Disable Selection							
		0	Disable allocation for CN1-10 input signal monitor.						
		1	Enable allocation for CN1-10 input signal monitor.						
	n.□X□□	Input Signal Monitor Allocation for CN1-11 (SVCMD_IO)							
		0 to 7	The settings are the same as the CN1-13 allocations.						
	n.X□□□	CN1-11 Input Signal Monitor Enable/Disable Selection							
		0	Disable allocation for CN1-11 input signal monitor.						
	1	Enable allocation for CN1-11 input signal monitor.							
Pn863 <b>M3</b> *8	2	SVCMD_IO Input Signal Monitor Allocations 4	0000h to 1717h	-	0000h	Rotary	Immediately	Setup	*2
	n.□□□X	Input Signal Monitor Allocation for CN1-12 (SVCMD_IO)							
		0 to 7	The settings are the same as the CN1-13 allocations.						
	n.□□X□	CN1-12 Input Signal Monitor Enable/Disable Selection							
		0	Disable allocation for CN1-12 input signal monitor.						
		1	Enable allocation for CN1-12 input signal monitor.						
n.□X□□	Reserved parameter (Do not change.)								
n.X□□□	Reserved parameter (Do not change.)								

Continued on next page.

Continued from previous page.

Parameter No.	Size	Name	Setting Range	Setting Unit	Default Setting	Applicable Motors	When Enabled	Classification	Reference	
Pn868 <b>M3</b> <sup>*8</sup>	2	SVCMD_IO Output Signal Monitor Allocations 1	0000h to 1717h	-	0000h	Rotary	Immediately	Setup	*2	
			<b>Output Signal Monitor Allocation for CN1-1 and CN1-2 (SVCMD_IO)</b>							
	n.□□□X		0	Allocate bit 24 (IO_STS1) to CN1-1/CN1-2 output signal monitor.						
			1	Allocate bit 25 (IO_STS2) to CN1-1/CN1-2 output signal monitor.						
			2	Allocate bit 26 (IO_STS3) to CN1-1/CN1-2 output signal monitor.						
			3	Allocate bit 27 (IO_STS4) to CN1-1/CN1-2 output signal monitor.						
			4	Allocate bit 28 (IO_STS5) to CN1-1/CN1-2 output signal monitor.						
			5	Allocate bit 29 (IO_STS6) to CN1-1/CN1-2 output signal monitor.						
			6	Allocate bit 30 (IO_STS7) to CN1-1/CN1-2 output signal monitor.						
			7	Allocate bit 31 (IO_STS8) to CN1-1/CN1-2 output signal monitor.						
			<b>CN1-1/CN1-2 Output Signal Monitor Enable/Disable Selection</b>							
	n.□□X□		0	Disable allocation for CN1-1/CN1-2 output signal monitor.						
			1	Enable allocation for CN1-1/CN1-2 output signal monitor.						
			<b>Output Signal Monitor Allocation for CN1-23 and CN1-24 (SVCMD_IO)</b>							
	n.□X□□		0 to 7	The settings are the same as the CN1-1/CN1-2 allocations.						
			<b>CN1-23/CN1-24 Output Signal Monitor Enable/Disable Selection</b>							
n.X□□□		0	Disable allocation for CN1-23/CN1-24 output signal monitor.							
		1	Enable allocation for CN1-23/CN1-24 output signal monitor.							
Pn869 <b>M3</b> <sup>*8</sup>	2	SVCMD_IO Output Signal Monitor Allocations 2	0000h to 1717h	-	0000h	Rotary	Immediately	Setup	*2	
	n.□□□X		<b>Output Signal Monitor Allocation for CN1-25 and CN1-26 (SVCMD_IO)</b>							
			0 to 7	The settings are the same as the CN1-1/CN1-2 allocations.						
			<b>CN1-25/CN1-26 Output Signal Monitor Enable/Disable Selection</b>							
	n.□□X□		0	Disable allocation for CN1-25/CN1-26 output signal monitor.						
			1	Enable allocation for CN1-25/CN1-26 output signal monitor.						
n.□X□□		Reserved parameter (Do not change.)								
n.X□□□		Reserved parameter (Do not change.)								
Pn87A	4	Last Rotational Coordinate	0 to 536,870,911	1 reference unit	0	Rotary	After restart	Setup	4.2.1	
Pn87C	4	First Rotational Coordinate	-536,870,912 to 0	1 reference unit	0	Rotary	After restart	Setup	4.2.1	

Continued on next page.

Continued from previous page.

Parameter No.	Size	Name	Setting Range	Setting Unit	Default Setting	Applicable Motors	When Enabled	Classification	Reference	
Pn87E	2	Rotational Coordinate Function Switch	0000h to 0003h	-	0000h	Rotary	Immediately	Setup	4.2.4	
	n.□□□X		<b>Movement Method for Rotational Coordinates</b>							
			0	Absolute positioning						
			1	Positioning in reverse direction						
			2	Positioning in forward direction						
			3	Positioning by near course						
	n.□□X□		Reserved parameter (Do not change.)							
n.□X□□		Reserved parameter (Do not change.)								
n.X□□□		Reserved parameter (Do not change.)								
Pn880	2	Station Address Monitor (for maintenance, read only)	03h to EFh	-	-	Rotary	-	Setup	-	
Pn881	2	Set Transmission Byte Count Monitor [bytes] (for maintenance, read only)	17, 32, 48	-	-	Rotary	-	Setup	-	
Pn882	2	Transmission Cycle Setting Monitor [ $\times 0.25 \mu\text{s}$ ] (for maintenance, read only)	0h to FFFFh	-	-	Rotary	-	Setup	-	
Pn883	2	Communications Cycle Setting Monitor [transmission cycles] (for maintenance, read only)	0 to 32	-	-	Rotary	-	Setup	-	
Pn884 <b>M3</b> *8	2	Communications Controls 2	0000h to 0001h	-	0000h	Rotary	Immediately	Setup	*2	
	n.□□□X		<b>MECHATROLINK Communications Error Holding Brake Signal Setting</b>							
			0	Maintain the status set by the BRK_ON or BRK_OFF command when a MECHATROLINK communications error occurs.						
			1	Apply the holding brake when a MECHATROLINK communications error occurs.						
	n.□□X□		Reserved parameter (Do not change.)							
	n.□X□□		Reserved parameter (Do not change.)							
n.X□□□		Reserved parameter (Do not change.)								
Pn88A	2	MECHATROLINK Receive Error Counter Monitor (for maintenance, read only)	0 to 65,535	-	0	Rotary	-	Setup	-	
Pn890 to Pn8A6	4	Command Data Monitor during Alarm/Warning (for maintenance, read only)	0h to FFFFFFFFh	-	0	Rotary	-	Setup	*2	
Pn8A8 to Pn8BE	4	Response Data Monitor during Alarm/Warning (for maintenance, read only)	0h to FFFFFFFFh	-	0	Rotary	-	Setup	*2	
Pn900	2	Number of Parameter Banks	0 to 16	-	0	Rotary	After restart	Setup	*2	
Pn901	2	Number of Parameter Bank Members	0 to 15	-	0	Rotary	After restart	Setup	*2	

Continued on next page.



Continued from previous page.

Parameter No.	Size	Name	Setting Range	Setting Unit	Default Setting	Applicable Motors	When Enabled	Classification	Reference
Pn902 to Pn910	2	Parameter Bank Member Definition	0000h to 08FFh	–	0h	Rotary	After restart	Setup	*2
Pn920 to Pn95F	2	Parameter Bank Data (Not saved in nonvolatile memory.)	0000h to FFFFh	–	0h	Rotary	Immediately	Setup	*2

\*1. Refer to the following manual for details.

  $\Sigma$ -7-Series  $\Sigma$ -7S SERVOPACK with MECHATROLINK-III Communications References Product Manual (Manual No.: SIEP S800001 28)

  $\Sigma$ -7-Series Drive  $\Sigma$ -7S SERVOPACK with MECHATROLINK-III Communications References and RJ-45 Connectors Product Manual (Manual No.: SIEP S800001 62)

\*2. Refer to the following manual for details.

  $\Sigma$ -7-Series AC Servo Drive MECHATROLINK-III Communications Standard Servo Profile Command Manual (Manual No.: SIEP S800001 31)

\*3. Set a percentage of the motor rated torque.

\*4. These parameters are for SERVOPACKs with a Safety Module. Refer to the following manual for details.

  $\Sigma$ -V-Series/ $\Sigma$ -V-Series for Large-Capacity Models/ $\Sigma$ -7-Series User's Manual Safety Module (Manual No.: SIEP C720829 06)

\*5. Normally set this parameter to 0. If you use an External Regenerative Resistor, set the capacity (W) of the External Regenerative Resistor.

\*6. The upper limit is the maximum output capacity (W) of the SERVOPACK.

\*7. These parameters are for SERVOPACKs with the dynamic brake option. Refer to the following manual for details.

  $\Sigma$ -7-Series AC Servo Drive  $\Sigma$ -7S/ $\Sigma$ -7W SERVOPACK with Dynamic Brake Hardware Option Specifications Product Manual (Manual No.: SIEP S800001 73)

\*8. This parameter is valid only when the MECHATROLINK-III standard servo profile is used.

\*9. The parameter setting is enabled after SENS\_ON command execution is completed.

\*10. Change the setting when the reference is stopped (i.e., while DEN is set to 1). If you change the setting during operation, the reference output will be affected.

\*11. The settings are updated only if the reference is stopped (i.e., only if DEN is set to 1).

\*12. Refer to the following manual for details.

  $\Sigma$ -7-Series AC Servo Drive MECHATROLINK-II Communications Command Manual (Manual No.: SIEP S800001 30)

\*13. This parameter is valid only when the MECHATROLINK-II-compatible profile is used.

\*14. The setting of Pn842 is valid while Pn817 is set to 0.

\*15. The setting of Pn844 is valid while Pn818 is set to 0.

\*16. You can check overspeed detection speed with MECHATROLINK-III Common Parameter 05 PnA0A (Maximum Output Speed).

## 6.3 List of MECHATROLINK-III Common Parameters

The following table lists the common MECHATROLINK-III parameters. These common parameters are used to make settings from the host controller via MECHATROLINK communications. Do not change the settings with the Digital Operator or any other device.

Parameter No.	Size	Name	Setting Range	Setting Unit [Resolution]	Default Setting	Applicable Motors	When Enabled	Classification	
01 PnA02	4	Encoder Type Selection (read only)	0h to 1h	-	-	Rotary	-	Device information	
		0000h							Absolute encoder
		0001h							Incremental encoder
02 PnA04	4	Motor Type Selection (read only)	0h to 1h	-	-	Rotary	-		
		0000h							Rotary Servomotor
		0001h							Linear Servomotor
03 PnA06	4	Semi-closed/Fully-closed Type (read only)	0h to 1h	-	-	Rotary	-		
		0000h							Semi-closed
		0001h							Fully-closed
04 PnA08	4	Rated Motor Speed (read only)	0h to FFFFFFFFh	1 min <sup>-1</sup>	-	Rotary	-	Device information	
05 PnA0A	4	Maximum Output Speed (read only)	0h to FFFFFFFFh	1 min <sup>-1</sup>	-	Rotary	-		
06 PnA0C	4	Speed Multiplier (read only)	-1,073,741,823 to 1,073,741,823	-	-	Rotary	-		
07 PnA0E	4	Rated Torque (read only)	0h to FFFFFFFFh	1 N·m	-	Rotary	-		
08 PnA10	4	Maximum Output Torque (read only)	0h to FFFFFFFFh	1 N·m	-	Rotary	-		
09 PnA12	4	Torque Multiplier (read only)	-1,073,741,823 to 1,073,741,823	-	-	Rotary	-	Device information	
0A PnA14	4	Resolution (read only)	0h to FFFFFFFFh	1 pulse/rev	-	Rotary	-		

Continued on next page.

Continued from previous page.

Parameter No.	Size	Name	Setting Range	Setting Unit [Resolution]	Default Setting	Applicable Motors	When Enabled	Classification	
21 PnA42	4	Electronic Gear Ratio (Numerator)	1 to 1,073,741,824	–	16	Rotary	After restart	Machine specifications	
22 PnA44	4	Electronic Gear Ratio (Denominator)	1 to 1,073,741,824	–	1	Rotary	After restart		
23 PnA46	4	Absolute Encoder Origin Offset	-1,073,741,823 to 1,073,741,823	1 reference unit	0	Rotary	Immediately*1		
24 PnA48	4	Multiturn Limit Setting	0 to 65,535	1 Rev	65535	Rotary	After restart		
25 PnA4A	4	Limit Setting	0h to 33h	–	0000h	Rotary	After restart		
		Bit 0	P-OT (0: Enabled, 1: Disabled)						
		Bit 1	N-OT (0: Enabled, 1: Disabled)						
		Bit 2	Reserved.						
		Bit 3	Reserved.						
		Bit 4	P-SOT (0: Disabled, 1: Enabled)						
		Bit 5	N-SOT (0: Disabled, 1: Enabled)						
Bits 6 to 31	Reserved.								
26 PnA4C	4	Forward Software Limit	-1,073,741,823 to 1,073,741,823	1 reference unit	1073741823	Rotary	Immediately		
27 PnA4E	4	Reserved parameter (Do not change.)	–	–	0	Rotary	Immediately		
28 PnA50	4	Reverse Software Limit	-1,073,741,823 to 1,073,741,823	1 reference unit	-1073741823	Rotary	Immediately		
29 PnA52	4	Reserved parameter (Do not change.)	–	–	0	Rotary	Immediately		
41 PnA82	4	Speed Unit*2	0h to 4h	–	0h	Rotary	After restart		
		0000h	Reference units/s						
		0001h	Reference units/min						
		0002h	Percentage (%) of rated speed*3						
		0003h	min <sup>-1</sup> *3						
		0004h	Maximum motor speed/40000000h*4						
Continued on next page.									

6.3 List of MECHATROLINK-III Common Parameters

Continued from previous page.

Parameter No.	Size	Name	Setting Range	Setting Unit [Resolution]	Default Setting	Applicable Motors	When Enabled	Classification
42 PnA84	4	Speed Base Unit Selection <sup>*3, *4</sup> (Set the value of n from the following formula: Speed unit selection (41 PnA82) × 10 <sup>n</sup> )	-3 to 3	-	0	Rotary	After restart	Unit settings
43 PnA86	4	Position Unit Selection	0h	-	0h	Rotary	After restart	
		0000h	Reference units					
44 PnA88	4	Position Base Unit Selection (Set the value of n from the following formula: Position unit selection (43 PnA86) × 10 <sup>n</sup> )	0	-	0	Rotary	After restart	
45 PnA8A	4	Acceleration Unit Selection	0h	-	0h	Rotary	After restart	
		0000h	Reference units/s <sup>2</sup>					
46 PnA8C	4	Acceleration Base Unit Selection (Set the value of n from the following formula: Acceleration unit selection (45 PnA8A) × 10 <sup>n</sup> )	4 to 6	-	4	Rotary	After restart	
47 PnA8E	4	Torque Unit Selection	1h to 2h	-	1h	Rotary	After restart	
		0001h	Percentage (%) of rated torque					
		0002h	Maximum torque/4000000h <sup>*5</sup>					
48 PnA90	4	Torque Base Unit Selection <sup>*5</sup> (Set the value of n from the following formula: Torque unit selection (47 PnA8E) × 10 <sup>n</sup> )	-5 to 0	-	0	Rotary	After restart	

Continued on next page.

Continued from previous page.

Parameter No.	Size	Name	Setting Range	Setting Unit [Resolution]	Default Setting	Applicable Motors	When Enabled	Classification																																								
49 PnA92	4	Supported Unit Systems (read only)	–	–	0601011Fh	Rotary	–	Unit settings																																								
		<table border="1"> <thead> <tr> <th colspan="2">Speed Units</th> </tr> </thead> <tbody> <tr> <td>Bit 0</td> <td>Reference units/s (1: Enabled)</td> </tr> <tr> <td>Bit 1</td> <td>Reference units/min (1: Enabled)</td> </tr> <tr> <td>Bit 2</td> <td>Percentage (%) of rated speed (1: Enabled)</td> </tr> <tr> <td>Bit 3</td> <td>min<sup>-1</sup> (rpm) (1: Enabled)</td> </tr> <tr> <td>Bit 4</td> <td>Maximum motor speed/4000000h (1: Enabled)</td> </tr> <tr> <td>Bits 5 to 7</td> <td>Reserved (0: Disabled).</td> </tr> <tr> <th colspan="2">Position Units</th> </tr> <tr> <td>Bit 8</td> <td>Reference units (1: Enabled)</td> </tr> <tr> <td>Bits 9 to 15</td> <td>Reserved (0: Disabled).</td> </tr> <tr> <th colspan="2">Acceleration Units</th> </tr> <tr> <td>Bit 16</td> <td>Reference units/s<sup>2</sup> (1: Enabled)</td> </tr> <tr> <td>Bit 17</td> <td>ms (acceleration time required to reach rated speed) (0: Disabled)</td> </tr> <tr> <td>Bits 18 to 23</td> <td>Reserved (0: Disabled).</td> </tr> <tr> <th colspan="2">Torque Units</th> </tr> <tr> <td>Bit 24</td> <td>N·m (0: Disabled)</td> </tr> <tr> <td>Bit 25</td> <td>Percentage (%) of rated torque (1: Enabled)</td> </tr> <tr> <td>Bit 26</td> <td>Maximum torque/40000000h</td> </tr> <tr> <td>Bits 27 to 31</td> <td>Reserved (0: Disabled).</td> </tr> </tbody> </table>								Speed Units		Bit 0	Reference units/s (1: Enabled)	Bit 1	Reference units/min (1: Enabled)	Bit 2	Percentage (%) of rated speed (1: Enabled)	Bit 3	min <sup>-1</sup> (rpm) (1: Enabled)	Bit 4	Maximum motor speed/4000000h (1: Enabled)	Bits 5 to 7	Reserved (0: Disabled).	Position Units		Bit 8	Reference units (1: Enabled)	Bits 9 to 15	Reserved (0: Disabled).	Acceleration Units		Bit 16	Reference units/s <sup>2</sup> (1: Enabled)	Bit 17	ms (acceleration time required to reach rated speed) (0: Disabled)	Bits 18 to 23	Reserved (0: Disabled).	Torque Units		Bit 24	N·m (0: Disabled)	Bit 25	Percentage (%) of rated torque (1: Enabled)	Bit 26	Maximum torque/40000000h	Bits 27 to 31	Reserved (0: Disabled).	
		Speed Units																																														
		Bit 0	Reference units/s (1: Enabled)																																													
		Bit 1	Reference units/min (1: Enabled)																																													
		Bit 2	Percentage (%) of rated speed (1: Enabled)																																													
		Bit 3	min <sup>-1</sup> (rpm) (1: Enabled)																																													
		Bit 4	Maximum motor speed/4000000h (1: Enabled)																																													
		Bits 5 to 7	Reserved (0: Disabled).																																													
		Position Units																																														
		Bit 8	Reference units (1: Enabled)																																													
		Bits 9 to 15	Reserved (0: Disabled).																																													
		Acceleration Units																																														
		Bit 16	Reference units/s <sup>2</sup> (1: Enabled)																																													
		Bit 17	ms (acceleration time required to reach rated speed) (0: Disabled)																																													
		Bits 18 to 23	Reserved (0: Disabled).																																													
		Torque Units																																														
		Bit 24	N·m (0: Disabled)																																													
		Bit 25	Percentage (%) of rated torque (1: Enabled)																																													
		Bit 26	Maximum torque/40000000h																																													
Bits 27 to 31	Reserved (0: Disabled).																																															
61 PnAC2	4	Speed Loop Gain	1,000 to 2,000,000	0.001 Hz [0.1 Hz]	40000	Rotary	Immediately																																									
62 PnAC4	4	Speed Loop Integral Time Constant	150 to 512,000	1 μs [0.01 ms]	20000	Rotary	Immediately																																									
63 PnAC6	4	Position Loop Gain	1,000 to 2,000,000	0.001/s [0.1/s]	40000	Rotary	Immediately																																									
64 PnAC8	4	Feedforward Compensation	0 to 100	1%	0	Rotary	Immediately																																									
65 PnACA	4	Position Loop Integral Time Constant	0 to 5,000,000	1 μs [0.1 ms]	0	Rotary	Immediately																																									
66 PnACC	4	Positioning Completed Width	0 to 1,073,741,824	1 reference unit	7	Rotary	Immediately																																									
67 PnACE	4	Near Signal Width	1 to 1,073,741,824	1 reference unit	1073741824	Rotary	Immediately																																									
81 PnB02	4	Exponential Acceleration/Deceleration Time Constant	0 to 510,000	1 μs [0.1 ms]	0	Rotary	Immediately*6																																									
82 PnB04	4	Movement Average Time	0 to 510,000	1 μs [0.1 ms]	0	Rotary	Immediately*6																																									
83 PnB06	4	External Positioning Final Travel Distance	-1,073,741,823 to 1,073,741,823	1 reference unit	100	Rotary	Immediately																																									
84 PnB08	4	Origin Approach Speed	0h to 3FFFFFFh	10 <sup>-3</sup> min <sup>-1</sup>	× 5,000h reference units/s converted to 10 <sup>-3</sup> min <sup>-1</sup>	Rotary	Immediately																																									

Continued on next page.

6.3 List of MECHATROLINK-III Common Parameters

Continued from previous page.

Parameter No.	Size	Name	Setting Range	Setting Unit [Resolution]	Default Setting	Applicable Motors	When Enabled	Classification
85 PnB0A	4	Origin Return Creep Speed	0h to 3FFFFFFh	10 <sup>-3</sup> min <sup>-1</sup>	× 500h reference units/s converted to 10 <sup>-3</sup> min <sup>-1</sup>	Rotary	Immediately	Tuning
86 PnB0C	4	Final Travel Distance for Origin Return	-1,073,741,823 to 1,073,741,823	1 reference unit	100	Rotary	Immediately	
87 PnB0E	4	Fixed Monitor Selection 1	0h to Fh	-	1h	Rotary	Immediately	
		0000h	APOS					
		0001h	CPOS					
		0002h	PERR					
		0003h	LPOS1					
		0004h	LPOS2					
		0005h	FSPD					
		0006h	CSPD					
		0007h	TRQ					
		0008h	ALARM					
		0009h	MPOS					
		000Ah	Reserved (undefined value).					
		000Bh	Reserved (undefined value).					
		000Ch	CMN1 (common monitor 1)					
000Dh	CMN2 (common monitor 2)							
000Eh	OMN1 (optional monitor 1)							
000Fh	OMN2 (optional monitor 2)							
88 PnB10	4	Fixed Monitor Selection 2	0h to Fh	-	0h	Rotary	Immediately	Command-related parameters
		0000h to 000Fh	The settings are the same as those for Fixed Monitor Selection 1.					

Continued on next page.

Continued from previous page.

Parameter No.	Size	Name	Setting Range	Setting Unit [Resolution]	Default Setting	Applicable Motors	When Enabled	Classification																																																				
89 PnB12	4	SEL_MON (CMN1) Monitor Selection 1	0000h to 0009h	-	0	Rotary	Immediately	Command-related parameters																																																				
		0000h	TPOS (target position in reference coordinate system)																																																									
		0001h	IPOS (reference position in reference coordinate system)																																																									
		0002h	POS_OFFSET (offset set in POS_SET (Set Coordinates) command)																																																									
		0003h	TSPD (target speed)																																																									
		0004h	SPD_LIM (speed limit)																																																									
		0005h	TRQ_LIM (torque limit)																																																									
		0006h	SV_STAT (servo actual operating status) Monitor Description Byte 1: Current communications phase 00h: Phase 0 01h: Phase 1 02h: Phase 2 03h: Phase 3 Byte 2: Current control mode 00h: Position control mode 01h: Speed control mode 02h: Torque control mode Byte 3: Reserved Byte 4: Expansion signal monitor																																																									
			<table border="1"> <thead> <tr> <th>Bit</th> <th>Name</th> <th>Description</th> <th>Value</th> <th>Setting</th> </tr> </thead> <tbody> <tr> <td rowspan="2">Bit 0</td> <td rowspan="2">LT_RDY1</td> <td rowspan="2">Processing status for latch detection for LT_REQ1 in SVCM-D_CTRL region</td> <td>0</td> <td>Latch detection not yet processed.</td> </tr> <tr> <td>1</td> <td>Processing latch detection in progress.</td> </tr> <tr> <td rowspan="2">Bit 1</td> <td rowspan="2">LT_RDY1</td> <td rowspan="2">Processing status for latch detection for LT_REQ2 in SVCM-D_CTRL region</td> <td>0</td> <td>Latch detection not yet processed.</td> </tr> <tr> <td>1</td> <td>Processing latch detection in progress.</td> </tr> <tr> <td rowspan="4">Bits 2 and 3</td> <td rowspan="4">LT_SEL1R</td> <td rowspan="4">Latch signal</td> <td>0</td> <td>Phase C</td> </tr> <tr> <td>1</td> <td>External input signal 1</td> </tr> <tr> <td>2</td> <td>External input signal 2</td> </tr> <tr> <td>3</td> <td>External input signal 3</td> </tr> <tr> <td rowspan="4">Bits 4 and 5</td> <td rowspan="4">LT_SEL2R</td> <td rowspan="4">Latch signal</td> <td>0</td> <td>Phase C</td> </tr> <tr> <td>1</td> <td>External input signal 1</td> </tr> <tr> <td>2</td> <td>External input signal 2</td> </tr> <tr> <td>3</td> <td>External input signal 3</td> </tr> <tr> <td>Bit 6</td> <td colspan="7">Reserved (0).</td> </tr> </tbody> </table>								Bit	Name	Description	Value	Setting	Bit 0	LT_RDY1	Processing status for latch detection for LT_REQ1 in SVCM-D_CTRL region	0	Latch detection not yet processed.	1	Processing latch detection in progress.	Bit 1	LT_RDY1	Processing status for latch detection for LT_REQ2 in SVCM-D_CTRL region	0	Latch detection not yet processed.	1	Processing latch detection in progress.	Bits 2 and 3	LT_SEL1R	Latch signal	0	Phase C	1	External input signal 1	2	External input signal 2	3	External input signal 3	Bits 4 and 5	LT_SEL2R	Latch signal	0	Phase C	1	External input signal 1	2	External input signal 2	3	External input signal 3	Bit 6	Reserved (0).							
			Bit	Name	Description	Value	Setting																																																					
			Bit 0	LT_RDY1	Processing status for latch detection for LT_REQ1 in SVCM-D_CTRL region	0	Latch detection not yet processed.																																																					
						1	Processing latch detection in progress.																																																					
			Bit 1	LT_RDY1	Processing status for latch detection for LT_REQ2 in SVCM-D_CTRL region	0	Latch detection not yet processed.																																																					
						1	Processing latch detection in progress.																																																					
			Bits 2 and 3	LT_SEL1R	Latch signal	0	Phase C																																																					
1	External input signal 1																																																											
2	External input signal 2																																																											
3	External input signal 3																																																											
Bits 4 and 5	LT_SEL2R	Latch signal	0	Phase C																																																								
			1	External input signal 1																																																								
			2	External input signal 2																																																								
			3	External input signal 3																																																								
Bit 6	Reserved (0).																																																											
0007h	Reserved.																																																											
0008h	INIT_PGPOS (Low)	Lower 32 bits of initial encoder position converted to 64-bit position reference data																																																										
0009h	INIT_PGPOS (High)	Upper 32 bits of initial encoder position converted to 64-bit position reference data																																																										

Continued on next page.

Continued from previous page.

Parameter No.	Size	Name	Setting Range	Setting Unit [Resolution]	Default Setting	Applicable Motors	When Enabled	Classification	
8A PnB14	4	SEL_MON (CMN2) Monitor Selection 2	0h to 9h	-	0h	Rotary	Immediately	Command-related parameters	
		0000h to 0009h	The settings are the same as those for SEL_MON Monitor Selection 1.						
8B PnB16	4	Origin Detection Width	0 to 250	1 reference unit	10	Rotary	Immediately		
8C PnB18	4	Forward Torque Limit	0 to 800	1%	100	Rotary	Immediately		
8D PnB1A	4	Reverse Torque Limit	0 to 800	1%	100	Rotary	Immediately		
8E PnB1C	4	Zero Speed Detection Range	1,000 to 10,000,000	10 <sup>-3</sup> min <sup>-1</sup>	20000	Rotary	Immediately		
8F PnB1E	4	Speed Coincidence Signal Detection Width	0 to 100,000	10 <sup>-3</sup> min <sup>-1</sup>	10000	Rotary	Immediately		
90 PnB20	4	Servo Command Control Field Enable/Disable Selections (read only)	-	-	0FFF3F3Fh	Rotary	-		
		Bit 0	CMD_PAUSE (1: Enabled)						
		Bit 1	CMD_CANCEL (1: Enabled)						
		Bits 2 and 3	STOP_MODE (1: Enabled)						
		Bits 4 and 5	ACCFIL (1: Enabled)						
		Bits 6 and 7	Reserved (0: Disabled).						
		Bit 8	LT_REQ1 (1: Enabled)						
		Bit 9	LT_REQ2 (1: Enabled)						
		Bits 10 and 11	LT_SEL1 (1: Enabled)						
		Bits 12 and 13	LT_SEL2 (1: Enabled)						
		Bits 14 and 15	Reserved (0: Disabled).						
		Bits 16 to 19	SEL_MON1 (1: Enabled)						
		Bits 20 to 23	SEL_MON2 (1: Enabled)						
		Bits 24 to 27	SEL_MON3 (1: Enabled)						
		Bits 28 to 31	Reserved (0: Disabled).						

Continued on next page.



Continued from previous page.

Parameter No.	Size	Name	Setting Range	Setting Unit [Resolution]	Default Setting	Applicable Motors	When Enabled	Classification
91 PnB22	4	Servo Status Field Enable/Disable Selections (read only)	–	0	0FFF3F33h	Rotary	–	Command-related parameters
		Bit 0	CMD_PAUSE_CMP (1: Enabled)					
		Bit 1	CMD_CANCEL_CMP (1: Enabled)					
		Bit 2 and 3	Reserved (0: Disabled).					
		Bits 4 and 5	ACCFIL (1: Enabled)					
		Bits 6 and 7	Reserved (0: Disabled).					
		Bit 8	L_CMP1 (1: Enabled)					
		Bit 9	L_CMP2 (1: Enabled)					
		Bit 10	POS_RDY (1: Enabled)					
		Bit 11	PON (1: Enabled)					
		Bit 12	M_RDY (1: Enabled)					
		Bit 13	SV_ON (1: Enabled)					
		Bits 14 and 15	Reserved (0: Disabled).					
		Bits 16 to 19	SEL_MON1 (1: Enabled)					
		Bits 20 to 23	SEL_MON2 (1: Enabled)					
		Bits 24 to 27	SEL_MON3 (1: Enabled)					
Bits 28 to 31	Reserved (0: Disabled).							
92 PnB24	4	Output Bit Enable/Disable Selections (read only)	–	–	007F01F0h	Rotary	–	Command-related parameters
		Bits 0 to 3	Reserved (0: Disabled).					
		Bit 4	V_PPI (1: Enabled)					
		Bit 5	P_PPI (1: Enabled)					
		Bit 6	P_CL (1: Enabled)					
		Bit 7	N_CL (1: Enabled)					
		Bit 8	G_SEL (1: Enabled)					
		Bits 9 to 11	G_SEL (0: Disabled)					
		Bits 12 to 15	Reserved (0: Disabled).					
		Bits 16 to 19	BANK_SEL (1: Enabled)					
		Bits 20 to 22	SO1 to SO3 (1: Enabled)					
		Bit 23	Reserved (0: Disabled).					
		Bits 24 to 31	Reserved (0: Disabled).					

Continued on next page.

Continued from previous page.

Parameter No.	Size	Name	Setting Range	Setting Unit [Resolution]	Default Setting	Applicable Motors	When Enabled	Classification		
93 PnB26	4	Input Bit Enable/Disable Selections (read only)	-	-	FF0FFEFh	Rotary	-	Command-related parameters		
	Bit 0		Reserved (0: Disabled).							
	Bit 1		DEC (1: Enabled)							
	Bit 2		P-OT (1: Enabled)							
	Bit 3		N-OT (1: Enabled)							
	Bit 4		EXT1 (1: Enabled)							
	Bit 5		EXT2 (1: Enabled)							
	Bit 6		EXT3 (1: Enabled)							
	Bit 7		ESTP (1: Enabled)							
	Bit 8		Reserved (0: Disabled).							
	Bit 9		BRK_ON (1: Enabled)							
	Bit 10		P-SOT (1: Enabled)							
	Bit 11		N-SOT (1: Enabled)							
	Bit 12		DEN (1: Enabled)							
	Bit 13		NEAR (1: Enabled)							
	Bit 14		PSET (1: Enabled)							
	Bit 15		ZPOINT (1: Enabled)							
	Bit 16		T_LIM (1: Enabled)							
	Bit 17		V_LIM (1: Enabled)							
	Bit 18		V_CMP (1: Enabled)							
	Bit 19		ZSPD (1: Enabled)							
Bits 20 to 23		Reserved (0: Disabled).								
Bits 24 to 31		I0_STS1 to I0_STS8 (1: Enabled)								

- \*1. The parameter setting is enabled after SENS\_ON command execution is completed.
- \*2. When using fully-closed loop control, set the reference units/s.
- \*3. If you set the Speed Unit Selection (parameter 41) to either 0002h or 0003h, set the Speed Base Unit Selection (parameter 42) to a number between -3 and 0.
- \*4. If you set the Speed Unit Selection (parameter 41) to 0004h, set the Speed Base Unit Selection (parameter 42) to 0.
- \*5. If you set the Torque Unit Selection (parameter 47) to 0002h, set the Torque Base Unit Selection (parameter 48) to 0.
- \*6. Change the setting when the reference is stopped (i.e., while DEN is set to 1). If you change the setting during operation, the reference output will be affected.

# Index

<b>A</b>	
absolute encoder origin offset - - - - -	4-4
alarm reset possibility - - - - -	5-3
<b>B</b>	
base block (BB)- - - - -	xii
baud rate	
SERVOPACK with MECHATROLINK-III	
communications references- - - - -	2-7
SERVOPACK with MECHATROLINK-III	
communications references and RJ-45	
connectors - - - - -	2-10
<b>C</b>	
coefficient of speed fluctuation	
SERVOPACK with MECHATROLINK-III	
communications references- - - - -	2-5
SERVOPACK with MECHATROLINK-III	
communications references and RJ-45	
connectors - - - - -	2-8
communications protocol	
SERVOPACK with MECHATROLINK-III	
communications references- - - - -	2-7
SERVOPACK with MECHATROLINK-III	
communications references and RJ-45	
connectors - - - - -	2-10
<b>D</b>	
degree of protection	
SERVOPACK with MECHATROLINK-III	
communications references- - - - -	2-5
SERVOPACK with MECHATROLINK-III	
communications references and RJ-45	
connectors - - - - -	2-8
<b>F</b>	
first rotational coordinate - - - - -	4-3
function application restrictions- - - - -	1-8
<b>I</b>	
I/O signals	
SERVOPACK with MECHATROLINK-III	
communications references- - - - -	2-6
SERVOPACK with MECHATROLINK-III	
communications references and RJ-45	
connectors - - - - -	2-9
<b>L</b>	
last rotational coordinate - - - - -	4-3
list of alarms - - - - -	5-3
list of MECHATROLINK-III common parameters - - - - -	6-40
list of servo parameters - - - - -	6-3
list of warnings - - - - -	5-34
<b>M</b>	
Main Circuit Cable - - - - -	xii
multiturn limit - - - - -	4-4
<b>O</b>	
output distance setting - - - - -	3-6
output function selection - - - - -	3-5
output position compensation setting - - - - -	3-7
output position setting - - - - -	3-5
output time setting- - - - -	3-6
<b>P</b>	
parameters	
notation (numeric settings) - - - - -	xiii
notation (selecting functions)- - - - -	xiii
pollution degree	
SERVOPACK with MECHATROLINK-III	
communications references - - - - -	2-5
SERVOPACK with MECHATROLINK-III	
communications references and RJ-45	
connectors - - - - -	2-8
<b>R</b>	
ratings- - - - -	2-2
rotational coordinate system - - - - -	4-2
monitoring - - - - -	4-12
<b>S</b>	
Servo Drive - - - - -	xii
servo lock- - - - -	xii
servo OFF- - - - -	xii
servo ON - - - - -	xii
Servo System - - - - -	xii
Servomotor - - - - -	xii
SERVOPACK - - - - -	xii
shock resistance	
SERVOPACK with MECHATROLINK-III	
communications references - - - - -	2-5
SERVOPACK with MECHATROLINK-III	
communications references and RJ-45	
connectors - - - - -	2-8
SigmaWin+ - - - - -	xii
specifications	
SERVOPACK with MECHATROLINK-III	
communications references - - - - -	2-5
SERVOPACK with MECHATROLINK-III	
communications references and RJ-45	
connectors - - - - -	2-8
station address settings	
SERVOPACK with MECHATROLINK-III	
communications references - - - - -	2-7
SERVOPACK with MECHATROLINK-III	
communications references and RJ-45	
connectors - - - - -	2-10

- storage humidity
  - SERVOPACK with MECHATROLINK-III communications references - - - - - 2-5
  - SERVOPACK with MECHATROLINK-III communications references and RJ-45 connectors - - - - - 2-8
- storage temperature
  - SERVOPACK with MECHATROLINK-III communications references - - - - - 2-5
  - SERVOPACK with MECHATROLINK-III communications references and RJ-45 connectors - - - - - 2-8
- surrounding air humidity
  - SERVOPACK with MECHATROLINK-III communications references - - - - - 2-5
  - SERVOPACK with MECHATROLINK-III communications references and RJ-45 connectors - - - - - 2-8
- surrounding air temperature
  - SERVOPACK with MECHATROLINK-III communications references - - - - - 2-5
  - SERVOPACK with MECHATROLINK-III communications references and RJ-45 connectors - - - - - 2-8

**T**

- transmission cycle
  - SERVOPACK with MECHATROLINK-III communications references - - - - - 2-7
  - SERVOPACK with MECHATROLINK-III communications references and RJ-45 connectors - - - - - 2-10
- triggers at preset positions
  - outline - - - - - 3-2
  - settings - - - - - 3-5
- troubleshooting alarms - - - - - 5-8
- troubleshooting warnings - - - - - 5-36

**V**

- vibration resistance
  - SERVOPACK with MECHATROLINK-III communications references - - - - - 2-5
  - SERVOPACK with MECHATROLINK-III communications references and RJ-45 connectors - - - - - 2-8

## Revision History

The date of publication, revision number, and Web revision number of the manual are given on the bottom right of the back cover. Refer to the following example.

MANUAL NO. SIEP S800002 28A <0>  
Published in Japan July 2017

Revision number  
Date of publication

Date of Publication	Rev. No.	Section	Revised Content
October 2019	<2>	Preface, Chapters 5, 6	Partly revised.
		Back cover	Revision: Address
October 2018	<1>	All chapters	Partly revised.
		Back cover	Revision: Address
July 2017	-	-	First edition

# Σ-7-Series AC Servo Drive Σ-7S SERVOPACK with FT/EX Specification for Transfer and Alignment Application with Special Motor, SGM7D Motor Product Manual

---

## **IRUMA BUSINESS CENTER (SOLUTION CENTER)**

480, Kamifujisawa, Iruma, Saitama, 358-8555, Japan  
Phone: +81-4-2962-5151 Fax: +81-4-2962-6138  
<http://www.yaskawa.co.jp>

## **YASKAWA AMERICA, INC.**

2121, Norman Drive South, Waukegan, IL 60085, U.S.A.  
Phone: +1-800-YASKAWA (927-5292) or +1-847-887-7000 Fax: +1-847-887-7310  
<http://www.yaskawa.com>

## **YASKAWA ELÉTRICO DO BRASIL LTDA.**

777, Avenida Piraporinha, Diadema, São Paulo, 09950-000, Brasil  
Phone: +55-11-3585-1100 Fax: +55-11-3585-1187  
<http://www.yaskawa.com.br>

## **YASKAWA EUROPE GmbH**

Hauptstraße 185, 65760 Eschborn, Germany  
Phone: +49-6196-569-300 Fax: +49-6196-569-398  
<http://www.yaskawa.eu.com> E-mail: [info@yaskawa.eu.com](mailto:info@yaskawa.eu.com)

## **YASKAWA ELECTRIC KOREA CORPORATION**

35F, Three IFC, 10 Gukjegeumyung-ro, Yeongdeungpo-gu, Seoul, 07326, Korea  
Phone: +82-2-784-7844 Fax: +82-2-784-8495  
<http://www.yaskawa.co.kr>

## **YASKAWA ASIA PACIFIC PTE. LTD.**

30A, Kallang Place, #06-01, 339213, Singapore  
Phone: +65-6282-3003 Fax: +65-6289-3003  
<http://www.yaskawa.com.sg>

## **YASKAWA ELECTRIC (THAILAND) CO., LTD.**

59, 1st-5th Floor, Flourish Building, Soi Ratchadapisek 18, Ratchadapisek Road, Huaykwang, Bangkok, 10310, Thailand  
Phone: +66-2-017-0099 Fax: +66-2-017-0799  
<http://www.yaskawa.co.th>

## **YASKAWA ELECTRIC (CHINA) CO., LTD.**

22F, Link Square 1, No.222, Hubin Road, Shanghai, 200021, China  
Phone: +86-21-5385-2200 Fax: +86-21-5385-3299  
<http://www.yaskawa.com.cn>

## **YASKAWA ELECTRIC (CHINA) CO., LTD. BEIJING OFFICE**

Room 1011, Tower W3 Oriental Plaza, No.1, East Chang An Ave.,  
Dong Cheng District, Beijing, 100738, China  
Phone: +86-10-8518-4086 Fax: +86-10-8518-4082

## **YASKAWA ELECTRIC TAIWAN CORPORATION**

12F, No. 207, Sec. 3, Beishin Rd., Shindian Dist., New Taipei City 23143, Taiwan  
Phone: +886-2-8913-1333 Fax: +886-2-8913-1513 or +886-2-8913-1519  
<http://www.yaskawa.com.tw>

---

# **YASKAWA**

**YASKAWA ELECTRIC CORPORATION**

In the event that the end user of this product is to be the military and said product is to be employed in any weapons systems or the manufacture thereof, the export will fall under the relevant regulations as stipulated in the Foreign Exchange and Foreign Trade Regulations. Therefore, be sure to follow all procedures and submit all relevant documentation according to any and all rules, regulations and laws that may apply.

Specifications are subject to change without notice for ongoing product modifications and improvements.

© 2017 YASKAWA ELECTRIC CORPORATION

MANUAL NO. SIEP S800002 28C <2>-0

Published in Japan October 2019

18-10-15

Original instructions